

Real Algebraic Varieties with Trivial Canonical Class and Toric Geometry

FLORIAN SCHWERTECK

DISSERTATION

der Fakultät für Mathematik und Physik
der Eberhard-Karls-Universität Tübingen
zur Erlangung des Grades eines
Doktors der Naturwissenschaften vorgelegt

2010

Tag der mündlichen Qualifikation: 5. Juli 2010

Dekan: Prof. Dr. Wolfgang Knapp

1. Berichterstatter: Prof. Dr. Viktor Batyrev (Tübingen)

2. Berichtstatterin: Prof. Dr. Hannah Markwig (Göttingen)

Contents

Introduction	5
I Preliminaries	15
1.1 Piecewise Linear Topology	15
1.2 Lattice Polytopes and Triangulations	36
II Toric Varieties	51
2.1 Toric Varieties over \mathbb{K}	51
2.2 Real Toric Varieties	62
2.3 Virtual Betti Numbers	70
III Real Local Toric Calabi-Yau Varieties	75
3.1 Definition	75
3.2 General Results	76
3.3 2-Dimensional Varieties	95
3.4 3-Dimensional Varieties	98
IV Real Compact Calabi-Yau Toric Hypersurfaces	115
4.1 Construction of Calabi-Yau Toric Hypersurfaces	115
4.2 Real K3 Surfaces	119
4.3 The Patchworking Method of Viro	128
4.4 Algorithms and Implementations	137
4.5 Euler Characteristic and Betti Numbers	149
4.6 Computer experiments	173

Bibliography	179
Glossary of Notations	187
Appendix A - Zusammenfassung auf Deutsch	191
Appendix B - Curriculum Vitae	195

Introduction

One of the most mysterious philosophical questions about mathematics is its relationship to reality. Most people would feel that such a relationship is “evident” as many developments in mathematics have been inspired by the observation of natural phenomena, reaching as far to the beginning as to the fundamental arithmetic equation $1 + 1 = 2$. But if we take into account that any mathematical statement is just a sequence of symbols, which is said to be true if it fulfills some rules which are in their turn interpretations of another sequence of symbols, then it is not clear why these should reflect any truth in the physical nature. Many cunning arguments have been given for both point of views over the time. We do not want to prosecute this philosophical question here, but rather point out that all the subsequent work deals with aspects of a very modern and deep “evidence”: the mirror symmetry.

Mirror symmetry deals with Calabi-Yau varieties which are compact complex algebraic varieties¹ X with the properties that $H^i(X, \mathcal{O}_X) = 0$ for all $i = 1, \dots, \dim X - 1$ and the canonical class is trivial. The last property is equivalent to the existence of a globally defined rational $(\dim X)$ -form without zeros nor poles.

Manifolds of this type were first considered by E. Calabi, who, in

¹In general they are defined to be “as smooth as possible” for a given context. While we will only consider smooth Calabi-Yau varieties, this class seems to be too restricted for an explanation of mirror symmetry, so one often allows some mild singularities, like Gorenstein terminal singularities. For the important 3-dimensional Calabi-Yau varieties, however, these distinctions are irrelevant.

the 50's, conjectured that they have a Ricci-flat metric (see [Cal]). The conjecture was finally proven by S.-T. Yau in [Yau] in 1978.

The 1-dimensional Calabi-Yau varieties turn out to be the elliptic curves, which had been studied long before and are now very well known. A similar statement can be made about the 2-dimensional Calabi-Yau varieties, which are commonly known as K3 surfaces.

3-dimensional Calabi-Yau varieties play an essential role for physicists in string theory. In this theory the Minkowski space-time $M_{3,1}$ known from special relativity theory is replaced by a 10-dimensional space that locally looks like $M_{3,1} \times V$, where V is a 3-dimensional complex Calabi-Yau variety (accounting for 6 real dimensions). V is considered to be so small that it cannot be perceived at a macroscopic level. 3-dimensional Calabi-Yau varieties are then used to construct so-called supersymmetric conformal field theories (SCFT) (see [CK] for more details). For some symmetry reasons in these constructions it turns out that a SCFT associated with a Calabi-Yau variety V should be equivalent to another SCFT associated with some Calabi-Yau variety V' . The relationship between V and V' is called mirror symmetry. It implies many striking connections between such a mirror pair. One of those is that the Hodge diamond of V is equal to that of V' reflected by an axis of angle 45° (hence the name of the symmetry; a more prosaic point of view is stating that $h^{1,1}(V) = h^{2,1}(V')$ and viceversa).

However, given V , it is not clear how to find or construct V' . Mirror symmetry as such is not even a well-defined mathematical statement, as in the definitions of the SCFTs mathematically non-defined objects, such as the Feynman path integral, occur. On the other hand it predicts many deep mathematical results, which have partially been verified and proved.

One of the first possible mathematical explanations of mirror symmetry was given by Batyrev ([Bat]), who showed that an anti-canonical hypersurface Z of a toric Gorenstein Fano variety X_Δ associated with a reflexive polytope Δ , is a Calabi-Yau variety, though in general not a smooth one. He further showed that, when \tilde{Z} is a maximal projective non-discrepant partial (MPCP-) desingulariza-

tion of Z and \tilde{Z}^* an analogously defined desingularization of an anticanonical hypersurface of X_{Δ^*} , where Δ^* is the dual polytope of Δ , then \tilde{Z} and \tilde{Z}^* fulfill the requirements on the hodge numbers implied by mirror theory (in all dimensions n for the generalized equation $h^{1,1}(V) = h^{n-1,1}(V)$). So, the mirror duality is in this case given by the duality operation on reflexive polytopes.

Very recent ideas have related the explanation of mirror symmetry of V to Lagrangian submanifolds of V (see [SYZ] and [Kon1]). If the Calabi-Yau variety is defined over the reals then an important example of a special Lagrangian submanifold is the set of real points. In particular this applies to all toric constructions.

There is a long tradition of studying real algebraic varieties. Solutions to real polynomial equations were already constructed when one could not yet write down such equations (many examples can be found in Arabian textbooks). In higher dimensions, the topological description of real algebraic varieties becomes a natural point of view, as algebraic methods do not work as well as they do for complex varieties. In general, two tasks can be distinguished: Describe the homeomorphism type of the varieties and, if applicable, the isotopy type of an embedding. In practice, the second task is relevant for curves, as their homeomorphism type is relatively easy to determine, whereas for all other real algebraic varieties the first task is already a tough problem. An attempt to classify real projective algebraic varieties by dimension and degree does not get all too far. Today, the isotopy classification of nonsingular real plane projective curves is known up to degree 7 (and large parts of degree 8), the degree 6 case being particularly famous for being part of the 16th problem in the famous list presented by Hilbert in his speech during a mathematical congress held in Paris in 1900 (see [Hil]). The latter was solved by Gudkov in 1965 ([Gud]). The advances in higher degrees were made possible by a new method introduced by Viro (see [Vi1]), which works naturally also in higher dimensions. We will use this method quite essentially in our work.

The homeomorphism type of smooth real surfaces in \mathbb{P}^3 are known up to degree 4. The last step was added by Kharlamov in 1974 ([Kha]).

There exist results for various subclasses, defined by abstract properties, of real algebraic varieties. An important subclass in this context is constituted by the real Calabi-Yau varieties. These are always orientable. Real elliptic curves can easily be shown as consisting of either 0, 1 or 2 circles. Real K3 surfaces coincide with the smooth real quartics in \mathbb{P}^3 , this being the reason for an intimate connection between this classification and the isotopy classification of nonsingular real plane projective degree 6 curves. In dimension 3 the problem is still wide open, it being not even clear whether the number of topological types is finite or not.

It is the basic idea of this dissertation to shed some more light into this area of research. For this, we use Batyrev's method of the construction of Calabi-Yau varieties as toric hypersurfaces in X_Δ . Our investigations then roughly split into two parts: One is the study of toric desingularizations of the hypersurface. These are described by means of a unimodular triangulation of Δ^* . It can locally be understood as the desingularization of a toric variety over a face of Δ^* (we call them real local toric Calabi-Yau varieties). The other one consists in using the method of Viro to construct the hypersurfaces. This yields an explicit topological model of the hypersurface as cell complex. Putting both parts together we get a purely combinatorial description in convex geometry of the resulting Calabi-Yau variety.

We use this mainly for the calculation of the Euler characteristic and Betti numbers. For this purpose it proves useful to assume that the triangulation used in the method of Viro is unimodular. Under this assumption we show that the Euler characteristic is independent of all choices in the construction for the local as well as for the compact varieties. The same is true for the Betti numbers in the compact case and in the local case for dimensions ≤ 3 . For general local Calabi-Yau varieties a similar independency result could only be proved for virtual Betti numbers.

But not only can convex geometry be used to derive topological properties of the varieties, also the opposite direction is possible. So, from the formula for the Euler characteristic we derive relations for

general lattice polytopes (in low dimensions) in the local case and for reflexive 4-dimensional polytopes out of the compact case.

In order to compute cohomology groups with integral coefficients we implemented a computer program which calculates these groups for hypersurfaces constructed with the Viro method. When these are smooth, they are already Calabi-Yau varieties. Unfortunately, these examples are also the computationally most expensive ones.

In this work we come into touch with some further classes of real algebraic varieties: A. Comessatti showed ([Com1]) that compact smooth real rational surfaces are connected and can be either non-orientable (of arbitrary type) or orientable with genus at most 1. We will present orientable surfaces which fulfill all properties but compactness, having arbitrary genus. Compact smooth real rational algebraic varieties of dimension 3 were investigated by J. Kollár (see [Kol0] - [Kol5]) by means of a minimal model program.

Delaunay classified real structures on compact toric varieties and determined their fixed point set in dimensions 2 and 3 ([Dly1]). The number of such varieties is finite and small. Again, missing compactness in our examples leads to a much larger diversity (namely infinitely many) of topological types.

This dissertation is divided into four chapters:

The first chapter is devoted to basic results in piecewise linear topology and convex geometry.

Piecewise linear topology is our natural setting for the topological description of real toric varieties. Our main contribution consists in the definition of a compactification \bar{P} of a polyhedron P , in such a way that \bar{P} is a polytope whose face poset extends the face poset of P in a natural way. This allows to handle non-compact toric varieties in a similar way to compact ones.

Convex geometry is the language to be used for the combinatoric description of any toric variety. We introduce notation and state necessary results on lattices, lattice polytopes, reflexive polytopes and unimodular triangulations. The fact that the number of simplices in a unimodular triangulations of a lattice polytope does

not depend on the particular choice of the triangulation will reflect in numerous independency results throughout our work.

Chapter II gives background information on general and real toric varieties for the reader who is not familiar with these concepts.

Toric varieties are normal algebraic varieties that contain the algebraic torus as open dense subset such that its action on itself extends to the whole variety. They can be defined over any field. One of their key features consists in a functorial relationship with certain objects of convex geometry. Various abstract algebraic properties can be “translated” into the world of convex geometry (and viceversa), where the objects are very concrete, easy to visualize and often more accessible to calculations. Toric varieties cover some of the most important examples of algebraic varieties, but they are somehow “handicapped” by the fact that they are always rational. This limitation can be overcome by considering not only the varieties themselves but also their subvarieties. In such a way, it is possible to obtain Calabi-Yau varieties (which are never rational).

We put particular interest to the case where Δ is a d -dimensional rational polyhedron and X_Δ the real toric variety associated with it. Then X_Δ is topologically obtained as the result of glueing of 2^d copies of Δ along their faces. The compactification $\overline{\Delta}$ of Δ , described in Chapter I, extends to X_Δ , resulting in a compact space $\overline{X_\Delta}$, where $\partial\overline{X_\Delta}$ is a smooth PL-manifold.

To calculate Betti numbers of toric varieties we use two devices:

One is a result of V. Uma ([Uma]), which yields a presentation of the fundamental group of real toric varieties.

The other one are virtual Betti numbers β^i . These are defined on all real algebraic varieties by their property of being additive on disjoint unions and coinciding with the classical Betti numbers on smooth compact real algebraic varieties. The virtual and the classical Euler numbers always coincide. With $\beta^i((\mathbb{R}^*)^d) = (-1)^{d-i} \binom{d}{i}$ the virtual Betti numbers of a real toric variety X are easily determined by its orbit decomposition and expressed in terms of its defining fan Σ as $\beta^i(X) = \sum_{k=0}^{d-i} (-1)^{d-i-k} \binom{d-k}{i} \#\Sigma(k)$.

In chapter III we deal with real local toric Calabi-Yau varieties. These are non-compact toric varieties associated with a fan over a convex polytope Θ with unimodular triangulation (see figure 1). Their Euler characteristic can be calculated by using the orbit decomposition. In low dimensions d we get: For $d = 2$ and $\Theta = [0, n]$: $\chi = 2 - n$, for $d = 3$: $\chi = l(\partial\Theta) - 4$ and for $d = 4$: $\chi = \frac{1}{2}\text{vol}(\Theta) + \kappa(\Theta) - 5l(\Theta) + 13$, where $\kappa(\Theta)$ designates the number of edges in the triangulation (this number depends only on Θ), and $l(\Theta) := \#(\Theta \cap \mathbb{Z}^3)$.

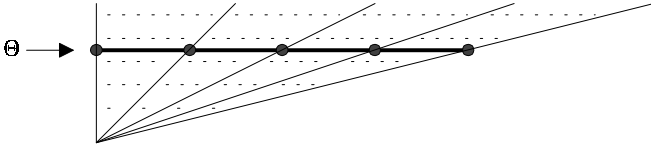

Figure 1: The fan over $\Theta = [0, 4]$

We show that the Euler characteristic and the virtual Betti numbers are independent of the particular choice of the triangulation.

The number of boundary components in the compactification-with-boundary is $2^{d-1-\dim_2 \partial\Theta}$, where $\dim_2 \partial\Theta$ designates the dimension of the \mathbb{F}_2 -subspace generated by the image of $\partial\Theta \cap \mathbb{Z}^{d-1}$, hence depends only on the boundary of the polytope.

In dimension $d = 2$ this number amounts to 1 or 2. The surfaces X are completely classified by their parameter n : If n is even, then $X \cong T_{\frac{n}{2}-1} \setminus \{2 \text{ pts.}\}$, whereas if n is odd, then $X \cong T_{\frac{n-1}{2}} \setminus \{1 \text{ pt.}\}$. Hereby T_g designates the orientable surface of genus g .

For 3-dimensional varieties such a complete result is not achieved. We are, however, able to calculate the integral (co-)homology groups and show that the classical Betti numbers coincide with the virtual Betti numbers and are independent of the triangulation. The Betti numbers with integral coefficients depend in general on the triangulation: In the first example of the figure below, $H_c^2(X, \mathbb{Z}) \cong \mathbb{Z}^3$, in the second $H_c^2(Y, \mathbb{Z}) \cong \mathbb{Z}^2 \times \mathbb{Z}/2\mathbb{Z}$.

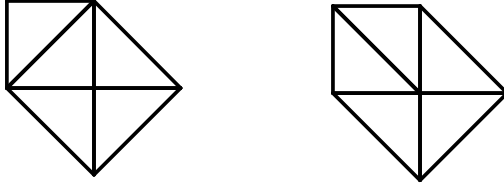

The triangulations defining X (left) and Y (right)

We conjecture that the topology of 3-dimensional real local Calabi-Yau varieties is characterized by their fundamental group.

In chapter IV we use Viro's combinatorial patchworking method for the construction of toric Calabi-Yau hypersurfaces.

In the first section we give an overview of the known topological classification of real K3 surfaces: They consist of a union of spheres of which one may have handles and are characterized by their number of components and their Euler characteristic (with one exception to that rule, as both $S^2 \cup T_2$ and $T_1 \cup T_1$ can be realized as real K3 surfaces).

In the second section we present Batyrev's construction of Calabi-Yau varieties: If Δ is a reflexive polytope, then a generic Laurent polynomial with Newton polytope Δ defines a Calabi-Yau variety Z in X_Δ (the toric variety associated with Δ), possibly with singularities. Locally around these singularities, Z looks like the toric variety associated with a certain face of Δ^* , the dual polytope of Δ . Hence, a desingularization can be described (locally) by means of a unimodular triangulation of that face and the real local toric Calabi-Yau variety defined by it.

In the third section we present the patchworking theorem of Viro. We will use a special case of it, which is called combinatorial patchworking: To combinatorial data consisting of a lattice polytope Δ , a lattice triangulation of it and a sign function on the vertices of the triangulation it constructs a topological model of a hypersurface in

X_Δ . The various choices possible give to a certain amount control over the topological properties of the hypersurface. As the hypersurface is then given a natural structure as cell complex it is possible (at least in theory) to calculate the homology groups straightaway. We develop and implement an algorithm to do these calculations on a computer (the commented source code is available at [VHH]) and explain the most interesting part of it, namely a combinatorial formula for the induced orientation of a cell on its boundaries, in the forth section.

In the fifth section we deduce numerical invariants of Calabi-Yau varieties constructed by using the combined methods of Batyrev and Viro. We show that the Euler characteristic is independent of all choices if a unimodular triangulation is used for Viro's method whereas the Betti numbers are independent of the resolution if the singular hypersurface is fixed. However, we present a 3-dimensional example which shows that the cohomology group with integer coefficients may depend on the resolution. For K3 surfaces the Euler characteristic turns out to be always -16, which allows only two topologically different surfaces, one with one component and another one with two components. A similar behaviour (1 or 2 components) is also observed in all examples of higher dimension (in the sixth section), so we conjecture that this must be a general principle valid for all dimensions.

For 3-dimensional Calabi-Yau varieties the Euler characteristic must be always zero, so with our formula and reversing the point of view we deduce a formula relating combinatorial properties of a reflexive 4-polytope and its dual:

$$\begin{aligned} & -15f_{4,4} + 14f_{3,4} + 7f_{3,3} - 12f_{2,4} - f_{2,3} - 3f_{2,2} \\ & + f_{1,4} + 4f_{1,3} + 2f_{1,2} + f_{1,1} \\ & = \sum_{F \in \Delta(2)} l(\partial F)(2 - l(F^*)) - \sum_{\Theta \in \Delta(1)} \text{vol}(\Theta)(3 - l(\partial\Theta^*)), \end{aligned}$$

where the $f_{i,j}$ designate the (well-defined) number of i -dimensional simplices contained in the interior of the j -dimensional faces in any unimodular triangulation (assuming that it exists).

In the last section we present the results of our computer experiments on Viro hypersurfaces. We make the following observations: Where the cohomology groups can be calculated, they are already determined by the number of components. Moreover, only 2-torsion occurs, reflecting an analogous property of real local toric Calabi-Yau varieties. The number of components is bounded by 2, if the triangulation is unimodular (otherwise it can be much higher).

Acknowledgements

I would like to thank my main advisor V. Batyrev for his continuous support in all aspects of my thesis. His mathematical guidance and his patience in bringing me back to the right track made this thesis possible. I thank my second advisor during my stay in Göttingen Y. Tschinkel for the time and energy spent to push forward my mathematical education and to introduce me to interesting research topics. I thank my second referee H. Markwig for having taken interest in my work and having agreed to review it. I thank the Deutsche Forschungsgesellschaft for their financial support as well for the time in the Graduiertenkolleg in Göttingen as for the final months in Tübingen.

I thank my family for all support and help provided throughout the time of my dissertation.

I Preliminaries

1.1 Piecewise Linear Topology

1.1.1 Definition: Let $A, B \subset \mathbb{R}^d$. The *join* of A and B is defined as

$$\overleftrightarrow{AB} := \{ta + (1-t)b \mid a \in A, b \in B, 0 \leq t \leq 1\}.$$

For a one-point set, we will write a instead of $\{a\}$.

1.1.2 Proposition: The “join” operation is associative and commutative.

Proof: See for instance [RS], Prop 2.1. □

1.1.3 Definition: A set $P \subset \mathbb{R}^d$ is called a *generalized polyhedron*² if it looks locally like a cone over a compact set, that is for all $x \in P$ there is a compact set L , $x \notin L$, such that xL is a (closed) neighbourhood of x in P .

Examples:

²In [RS] it is just called polyhedron. It is a natural object in p.l. topology. We will use the term instead for a more restricted class of objects which arises naturally in convex geometry.

- a) Let $L \subset \mathbb{R}^d$ be compact, $v \in \mathbb{R}^d$, $v \notin L$. Then $C := \{v + t(x - v) \mid x \in L, t \geq 0\}$ is called the *cone* generated by L , with vertex v .
- b) $\{x^2 + y^2 \leq 1\} \subset \mathbb{R}^2$.
- c) $\{x^2 + y^2 < 1\} \subset \mathbb{R}^2$.
- d) $\{x^2 + y^2 < 1\} \cup \{(1, 0)\} \subset \mathbb{R}^2$.

It is easy to verify that a) and c) are generalized polyhedra, whereas b) and d) are not.

1.1.4 Definition: A map $F : P \rightarrow P'$ between two generalized polyhedra is called *affine linear* if for all $x, y \in P$

$$f(tx + (1 - t)y) = tf(x) + (1 - t)f(y)$$

for all $0 \leq t \leq 1$ such that $tx + (1 - t)y \in P$.

1.1.5 Definition: A map $f : P \rightarrow P'$ between two generalized polyhedra is called *piecewise linear (p.l.)* if the graph of f is again a generalized polyhedron. We say that P and P' are *piecewise linear homeomorphic*, if there are piecewise linear maps $f : P \rightarrow P'$ and $g : P' \rightarrow P$ with $f \circ g = \text{id}_{P'}$, $g \circ f = \text{id}_P$.

Examples:

- a) Affine linear maps are piecewise linear.
- b) The map $f : [0, 1] \rightarrow \mathbb{R}$, $f(x) = 0$ if $0 \leq x \leq \frac{1}{2}$ and $f(x) = 2x - 1$ otherwise, is piecewise linear.
- c) Let $I = \{(a, a) \mid 0 \leq a \leq 1\}$, $p = (0, 2)$. The projection of I from p on the x_1 -axis is not piecewise linear as the graph is not a generalized polyhedron ($x_1(a) = \frac{a}{2-a}$, which gives a part of a hyperbola).

Remark: Examples a) and b) are typical in the sense that piecewise linear maps will turn out always to be linear on some appropriate pieces, as their name suggests.

1.1.6 Definition: (a) Let $P \subset \mathbb{R}^d$ be the intersection of a finite set of affine halfspaces:

$$P = \bigcap_{i \in I} \{\alpha_i \geq a_i\},$$

where I is a finite set, the $\alpha_i, i \in I$, are linear forms and $a_i, i \in I$, real numbers. We call P a *polyhedron*. We call P a *pointed polyhedron* if it is nonempty and has a *vertex*, that is a point $x \in P$ such that

$$\{x\} = P \cap \bigcap_{j \in J} \{\alpha_j = a_j\}$$

for some subset $J \subset I$. Any nonempty set which has the form $P \cap \bigcap_{j \in J} \{\alpha_j = a_j\}$ for some $J \subset I$ is called *face* of P . A maximal proper face is called a *facet*.

If P is bounded, then we call it a *polytope*.

We designate by $\text{Aff}(P)$ the smallest affine subspace of \mathbb{R}^d containing P , and by $\text{Lin}(P)$ the linear subspace of \mathbb{R}^d parallel to $\text{Aff}(P)$.

The *dimension* of P is the dimension of $\text{Aff}(P)$, or equivalently of $\text{Lin}(P)$.

Remark: Polytopes and pointed polyhedra are in fact not very different objects, as for any pointed polyhedron it is possible to get a polytope by just adding one more affine inequality. The additional inequality can even be chosen such that in the combinatorics of the faces it results in a natural “addition” of faces. We will make use of such canonical “compactifications” later on.

The faces of a polyhedron P depend only on P and not on the set of inequalities actually used to define P . This follows from the fact that we can not only throw out useless inequalities from the definition of P (this is quite obvious), but also eliminate the corresponding equality in the definition of any face F . To show this we

can assume without loss of generality that P is fulldimensional and that no linear form (defined up to a multiple) occurs twice in the definition of P . Then the assertion is a consequence of the following:

1.1.7 Proposition: *Let*

$$P = \{\alpha \geq a\} \cap \bigcap_{i \in I} \{\alpha_i \geq a_i\}$$

be a polyhedron (where I is a finite set) and $F = P \cap \{\alpha = a\}$. Assume that P is fulldimensional and $\alpha \neq \lambda \alpha_i$ for all $\lambda \geq 0, i \in I$.

The following statements are equivalent:

- (i) The inequality $\alpha \geq a$ is superfluous for the definition of P , that is $P = \bigcap_{i \in I} \{\alpha_i \geq a_i\}$.
- (ii) For all $x \in F$ there is an $i \in I$ such that $\alpha_i(x) = a_i$.
- (iii) There is an $i \in I$ such that $\alpha_i|_F = a_i$.
- (iv) $\dim F \leq \dim P - 2$.
- (v) For any face G of P we have $G \cap F = G \cap \bigcap_{\alpha_i|_F \equiv a_i} \{\alpha_i = a_i\}$.

Proof: i) \Rightarrow ii): Let $x \in F$. Assume that $\alpha_i(x) > a_i$ for all $i \in I$. As I is a finite set, there exists a small neighbourhood U of x , such that $\alpha_i(x') > a_i$ for all $x' \in U, i \in I$. Let $y \in \mathbb{R}^d$ with $\alpha(y) < a$ (such a y must exist, since by assumption α is not the zero-function). Set $y_t := x + t(y - x)$ for $t > 0$. For t small enough $y_t \in U$, so $\alpha_i(y_t) > a_i$ for all $i \in I$, but $\alpha(y_t) = t\alpha(y) < a$, in contradiction to the assumption that $\alpha \geq a$ is a superfluous inequality. Thus there must be an $i \in I$ with $\alpha_i(x) = a_i$.

ii) \Rightarrow iii): Let x be any point in the interior of F (e.g. the barycenter of a basis of the affine space spanned by F). By assumption there is an $i \in I$ such that $\alpha_i(x) = a_i$. If there is a point $y \in F$, such that $\alpha_i(y) > a_i$, then for $y_t := x + t(y - x)$ we have $\alpha_i(y_t) < a_i$

for all $t < 0$, so $y_t \notin P$, but for $|t|$ small enough $y_t \in F$, hence a contradiction. So $\alpha_i(y) = a_i$ for all $y \in F$.

iii) \Rightarrow iv): Let $V := \{\alpha = a\}$, $V' := \{\alpha_i = a_i\}$, where $\alpha_i|_F = a_i$. α_i is not constant on V , otherwise it would be a multiple of α . As we have excluded the possibility of nonnegative multiples, it would be a negative multiple. But then $P \subset \{\alpha \geq a\} \cap \{-\alpha \cap -a\} = \{\alpha = a\}$, and P would not be fulldimensional. So this is excluded as well. As a consequence we have $V \cap V' \subsetneq V$ and from $F \subset V \cap V'$ follows $\dim F \leq \dim(V \cap V') = \dim V - 1 = \dim P - 2$.

iv) \Rightarrow i): Let $V := \{\alpha = a\}$ and W be the affine space spanned by F . Let $y \in \mathbb{R}^d$ with $\alpha(y) < a$. Assume that for all $x \in V \setminus F$ the line through x and y never meets P . Then P is contained in the affine space spanned by F and y , which has dimension $\dim F + 1 \leq \dim P - 1$, hence a contradiction.

So there is an $x \in V \setminus F$ such that the line through x and y meets P , say in y' . As $\{x\} \neq P$ there is an $i \in I$ with $\alpha_i(x) < a_i$. On the other hand $\alpha(y') \geq a_i$, so $\alpha_i(y) < a_i$. So the inequality $\alpha = a$ is superfluous for the definition of P .

i) \Rightarrow v): Let

$$J := \{i \in I \mid \alpha_i|_F \equiv a_i\}.$$

One inclusion is clear. For the other inclusion we have to show that any $x \in G \cap \bigcap_{j \in J} \{\alpha_j = a_j\}$ is also contained in $F \cap G$. Assume that it is not, so $\alpha(x) > a$. Let $y \in F$ such that $\alpha_k(y) > 0$ for all $k \in I \setminus J$ (by definition for each $k \in I \setminus J$ a $y_k \in F$ with $\alpha_k(y_k) > a_k$ exists, then take e.g. $y := \frac{1}{\#(I \setminus J)} \sum_{k \in I \setminus J} y_k$). Let W be the line through x and y , then there is a point $y' \in W$ close to x such that $\alpha_k(y') > a_k$ for all $k \in I \setminus J$, but $\alpha(y') < a$. So $y' \notin P$, therefore there must be an $i \in I$ such that $\alpha_i(y') < a_i$. By our construction we must have $i \in J$. But then $\alpha_i(y) = a_i = \alpha_i(x)$, so also $\alpha_i(y') = a_i$ which is a contradiction, whence the claim.

v) \Rightarrow iii) Taking $G = P$ we have $F = P \cap F = P \cap \bigcap_{j \in J} \{\alpha_j = a_j\}$, where J is defined as before. As $F \neq P$, J must be nonempty, so the required condition is fulfilled. \square

The proposition shows that we can define all faces without using superfluous linear forms. We will henceforth assume that all polyhedra are full-dimensional (where this makes sense) and that no superfluous inequalities occur in their definition.

- 1.1.8 Proposition:** (i) *A polyhedron is a convex generalized polyhedron.*
- (ii) *A polytope is a pointed polyhedron.*
- (iii) *The faces of a polyhedron (pointed polyhedron resp. polytope) are again polyhedra (pointed polyhedra resp. polytopes).*
- (iv) *The intersection of two faces is again a face: of the polyhedron as well as of the intersecting faces.*
- (v) *A face is a facet if and only if it has codimension 1.*
- (vi) *Every polyhedron P with $P \neq \text{Aff}(P)$ has a facet.*

Proof:

- (i) Let $x \in P = \bigcap_{i=1}^s \{\alpha_i \geq a_i\}$ and $\varepsilon := \min\{\alpha_i(x) \mid \alpha_i(x) \neq 0\} > 0$. Then the closed ball $B_\varepsilon(x)$ is a cone $\overline{x(\partial B_\varepsilon(x) \cap P)}$. Convexity follows from the fact, that if $\alpha(x) \geq 0$ and $\alpha(y) \geq 0$ for a linear form α , then also $\alpha(tx + (1-t)y) = t\alpha(x) + (1-t)\alpha(y) \geq 0$ (for $0 \leq t \leq 1$).
- (ii) Any minimal face is equal to the affine space defined by it (as there are no further restrictions by inequalities). As it is bounded, it must be 0-dimensional, hence a point.
- (iii) This is immediate for polytopes and polyhedra. If P is a pointed polyhedron it remains to show that every face has a vertex. So let F be a face of P . Let V be a minimal (nonempty) face contained in F . Then V is an affine subspace of \mathbb{R}^d . Now let x be a vertex of P and $x' \in V$. $V + (x - x')$ fulfills the same equalities and inequalities as those defining x , as for any $y \in V$ and α linear form from the definition

of P , $\alpha(y + (x - x')) = \alpha(y) - \alpha(x') + \alpha(x) = \alpha(x)$. Thus $V - (x - x') \subset \{x\}$, which is only possible if $V = \{x'\}$.

(iv) This follows from the definition.

(v) We first show the “only if”-direction: Let P be a polyhedron and F a facet. Then there is at least one equation $\alpha = a$ from the definition of F , such that $P \cap \{\alpha = a\} \neq P$. On the other hand, $F \subset P \cap \{\alpha = a\}$, so by the maximality of F we have $F = P \cap \{\alpha = a\}$. So we have $\dim F \leq \dim P - 1$. By proposition 1.1.7 $\dim F \geq \dim P - 1$, so $\dim F = \dim P - 1$.

For the other direction: Let F be a face of codimension one and F' the maximal proper face of P containing F . Then F is of codimension one, too (otherwise we would have $F = P$), but then F is a face of F' with the same dimension, hence $F = F'$.

(vi) As $P \neq \text{Aff}(P)$, P is defined by at least one inequality, which defines a facet in the obvious way.

□

1.1.9 Corollary: *The set of faces of a pointed polyhedron P is partially ordered by inclusion and has the property that every maximal chain has length equal to $\dim P + 1$ and contains exactly one face of dimension k for every $0 \leq k \leq \dim P$.*

Proof: This is an immediate consequence of the previous proposition. □

1.1.10 Definition: A *combinatorial map* between two polyhedra is an order-preserving map between the sets of faces. We call two polyhedra *combinatorially equivalent* if there is an order-preserving bijection between the sets of faces.

1.1.11 Definition: A polytope σ is called a *simplex*, if it is defined by $d + 1$ not superfluous inequalities, where $d = \dim \sigma$. The d -dimensional *standard simplex* is defined as

$$\sigma^{(d)} := \{(x_1, \dots, x_d) \in \mathbb{R}^d \mid x_i \geq 0 \ \forall i = 1, \dots, d, -\sum_{i=1}^d x_i \geq -1\}.$$

In the following, we list some well-known properties of simplices:

1.1.12 Proposition: *Let σ be a polytope. The following statements are equivalent:*

- (i) σ is a d -dimensional simplex.
- (ii) σ is the convex hull of $d + 1$ points not contained in any $(d - 1)$ -dimensional affine space.
- (iii) σ is the repeated join of $d + 1$ points not contained in any $(d - 1)$ -dimensional affine space.
- (iv) σ is linearly equivalent to the standard simplex $\sigma^{(d)}$, that is, σ can be transformed into $\sigma^{(d)}$ by an affine linear map and viceversa.
- (v) σ is a polytope combinatorially equivalent to $\sigma^{(d)}$.
- (vi) Any two faces of σ of dimension ≥ 1 have nonempty intersection.
- (vii) σ has $\binom{d}{k}$ faces of dimension k , $k = 1, \dots, d$.

Proof: The stated facts can be regarded as “common knowledge”, thus we leave it to the interested reader to carry out the technical details of the proof if he wishes to do so. \square

1.1.13 Definition: A *polyhedral complex* K is a finite set of polyhedra, such that:

- (i) For all $P, P' \in K$, the intersection $P \cap P'$ is either empty or a common face of both P and P' ,
- (ii) for all $P \in K$: If F is a face of P , then $F \in K$.

If all the polyhedra are simplices, then K is called a simplicial complex. $|K| := \bigcup_{P \in K} P$ is called the *underlying generalized polyhedron* or the *realization* of K .

If P is a polyhedron, then we call $\mathcal{K}(P) := \{F \mid F \text{ is a face of } P\}$ the *associated complex* to P . We will sometimes denote the associated complex also by P , when no misunderstanding is possible.

$\dot{P} := \{F \mid F \text{ is a proper face of } P\}$ is called the *frontier* of P . We often write ∂P for $|\dot{P}|$, although this might be misleading when P is not fulldimensional.

The *interior* of P is defined as the generalized polyhedron $\text{Int}(P) := P \setminus \partial P$.

1.1.14 Definition: We call a map $f : K \rightarrow K'$ of polyhedral complexes a *combinatorial map* if it preserves the partial ordering (i.e. $P \subset P' \Rightarrow f(P) \subset f(P')$). If f is surjective, then K is called a *subdivision* of K' . Two polyhedral complexes are *combinatorially equivalent*, if there are combinatorial maps $f : K \rightarrow K'$ and $g : K' \rightarrow K$ with $g \circ f = \text{id}_K, f \circ g = \text{id}_{K'}$.

There is a strong relationship between generalized polyhedra and simplicial complexes. Of course, every simplicial complex is a generalized polyhedron. But also the other direction “almost” holds: Every generalized polyhedron locally looks like a simplicial complex.

1.1.15 Proposition: a) A subset $P \subset \mathbb{R}^d$ is a generalized polyhedron if and only if it is a locally finite union of simplices. If P is compact, the set of simplices can be chosen to be finite, and P is the underlying generalized polyhedron of a simplicial complex.

b) A map $f : P \rightarrow P'$ between generalized polyhedra is piecewise linear if and only if f is continuous and P can be written as a

locally finite union of simplices, such that f is affine linear on each simplex. Again, if P is compact, the set of simplices can be chosen to be finite.

Proof: See [Hud], Chapter III, Theorem 3.6. \square

1.1.16 Definition: Let P be a polytope with vertices v_1, \dots, v_s . Then

$$\hat{P} := \frac{1}{s} \sum_{i=1}^s v_i$$

is the *barycenter* of P .

1.1.17 Definition: Let $K = \{P_i \mid i \in I\}$ be a polyhedral complex consisting of polytopes. Then we call the following simplicial complex \tilde{K} a barycentric subdivision of K :

The k -simplices of \tilde{K} are defined as the repeated join of all $\overleftarrow{P_{i_0} \dots P_{i_k}}$ such that $P_{i_0} \subset \dots \subset P_{i_k}$.

Remark: We can think of \tilde{K} as being inductively constructed as follows: The 0-simplices are taken to be the 0-dimensional polytopes in K . Then, assuming to have constructed the barycentric subdivision $\tilde{K}_{\leq k}$ of the k -skeleton of K (the subset of polytopes with dimension $\leq k$), we define the barycentric subdivision of the $(k+1)$ -skeleton as

$$\tilde{K}_{\leq k+1} := \tilde{K}_{\leq k} \cup \{\overleftrightarrow{P_i \sigma} \mid \sigma \in \tilde{K}_{\leq k}, \sigma \subset \partial P_i\},$$

where the P_i are the $(k+1)$ -dimensional polytopes of K .

It is not difficult to verify that the underlying generalized polyhedron of \tilde{K} is equal to that of K and that for any two combinatorially equivalent polyhedral complexes also their barycentric subdivisions are combinatorially equivalent by a canonical bijection.

1.1.18 Theorem: Let P be a pointed polyhedron. Then there are a linear form α and a real number a , such that

$$\bar{P} := P \cap \{\alpha \geq a\}$$

is a polytope and

$$\begin{aligned} f : \mathcal{K}(P) &\rightarrow \mathcal{K}(\overline{P}) \setminus \mathcal{K}(G) \\ F &\mapsto F \cap \{\alpha \geq a\} \end{aligned}$$

is an order-preserving bijection, where $G = P \cap \{\alpha = a\}$.

We call \overline{P} a closure of P and G a closing face.

Proof: Let v be a vertex of P and \overleftarrow{vL} a cone neighbourhood of v in P . Let C be the cone generated by v and L . As P is convex, $P \subset C$. Without loss of generality, we can assume that v is the origin and $\{v\} = P \cap \bigcap_{i \in I} \{\alpha_i = 0\}$. Set $\alpha := \sum_{i \in I} \alpha_i$. Then $P \subset \{\alpha \geq 0\}$ and $P \cap \{\alpha = 0\} = v$. As P and C are identical locally around v , the same is valid for C . We claim that for all $n \in \mathbb{N}$, $C \cap \{\alpha \leq n\}$ is bounded. Indeed, let $t := \text{dist}(v, L) > 0$ and N be a bound for L . Let $x \in C \cap \{\alpha \leq n\}$. By definition, $x = sx'$ for some $s \geq 0$ and $x' \in L$. From

$$n \geq \alpha(x) = \alpha(sx') = s\alpha(x') \geq st$$

we get that $s \leq \frac{n}{t} < \infty$. So $\frac{n}{t}N$ is a bound for $C \cap \{\alpha \leq n\}$ and hence also for $P \cap \{\alpha \leq n\}$.

Let n be large enough, such that $P \cap \{\alpha \leq n\}$ contains all bounded faces of P (this is possible, since there are only finitely many). Define

$$\overline{P} := P \cap \{\alpha \leq n+1\} = P \cap \{-\alpha \geq -n-1\}.$$

We have already shown that it is a polytope. It remains to show that the map f is indeed an order-preserving bijection.

It is immediate that f preserves the ordering. Furthermore, we note that f preserves the dimension. Indeed, if F is a face of P and $\dim(F \cap \{\alpha \leq n+1\}) < \dim F$ then we must have $F \subset \{\alpha \geq n+1\}$. But this is impossible, since F has a vertex v , and we have $\alpha(v) \leq n$ by construction.

We show now that f is injective: This is surely true for the vertices, as they are mapped on themselves. If F, F' are faces of

higher dimension with $f(F) = f(F')$, then, by induction, they have the same (sub-)faces. But as they have the same dimension, they must be equal.

For surjectivity, let \bar{F} be a face of \bar{P} , $F \subsetneq G$. So

$$\bar{F} = P \cap \{\alpha \leq n + 1\} \cap \bigcup_{j \in J} \{\alpha_j = a_j\},$$

where the $\alpha_j \geq a_j$ are from the definition of \bar{P} . Since $F \subsetneq G = \bar{P} \cap \{\alpha = n + 1\}$, we have that $\alpha \neq \alpha_j$ for all $j \in J$. But then $F = P \cap \bigcup_{j \in J} \{\alpha_j = a_j\}$ is a face of P and clearly $f(F) = \bar{F}$, hence the assertion, which concludes the proof. \square

1.1.19 Theorem: *The map*

$$\begin{aligned} g : \{F \mid F \text{ is an unbounded face of } P\} &\rightarrow \mathcal{K}(G) \\ F &\mapsto F \cap \{\alpha = n + 1\} \end{aligned}$$

is an order-preserving bijection.

Proof: First we note that $\dim g(F) = \dim F - 1$, as $\alpha \geq n + 1$ is not a superfluous inequality for the definition of $f(F) = F \cap \{\alpha \leq n + 1\}$. Furthermore, g is clearly order-preserving. Now let F, F' be unbounded faces with $g(F) = g(F')$ and $x \in \text{Int}(g(F))$. Then $x \in \text{Int}(F)$ (for if x is contained in some proper face H of F , then also in $g(H)$ which is a proper face of $g(F)$) and for the same reason $x \in \text{Int}(F')$. So $F \subset F'$ (or $F' \subset F$), but as they have the same dimension, we must have $F = F'$ and g is injective.

For surjectivity, let F be a face of G , $F = P \cap \{\alpha = n + 1\} \cap \bigcap_{j \in J} \{\alpha_j = a_j\}$, where $\alpha \neq \alpha_j$ for all $j \in J$. Then the polyhedron $H := P \cap \bigcap_{j \in J} \{\alpha_j = a_j\}$ is a face of P with $g(H) = F$, completing the proof. \square

1.1.20 Definition: Let K be a polyhedral complex. Then we call

$$\chi(K) := \sum_{P \in K} (-1)^{\dim P}$$

the *Euler characteristic* of K . If X is the underlying generalized polyhedron of a polyhedral complex K , then we define the Euler characteristic of X as

$$\chi(X) := \chi(K).$$

1.1.21 Proposition: a) *The above defined Euler characteristic of an underlying polyhedron is well defined, so for K, K' polytopal complexes with $|K| = |K'|$ we have $\chi(K) = \chi(K')$.*

b) *The Euler characteristic is additive, that is for two polyhedra X, X'*

$$\chi(X \cup X') = \chi(X) + \chi(X') - \chi(X \cap X').$$

Proof: These are well-known facts about the Euler characteristic. \square

1.1.22 Proposition: *The Euler characteristic of a pointed polyhedron P is 1 if P is bounded, and 0 if it is unbounded.*

Proof: It is well known that the Euler characteristic of a compact polytope is 1. If P is unbounded, then we can consider it (at least combinatorially) as $\overline{P} \setminus G$, where \overline{P} is a closure of P and G a closing face. So $\chi(P) = \chi(\overline{P}) - \chi(G) = 1 - 1 = 0$. \square

1.1.23 Corollary: *If P, P' are two combinatorially equivalent pointed polyhedra then also their closures \overline{P} and \overline{P}' as well as their respective closing faces G and G' are combinatorially equivalent.*

Proof: As the Euler characteristic is clearly a combinatorial invariant, the set of unbounded faces of P is mapped to the set of unbounded faces of P' by the combinatorial equivalence mapping P to P' . The assertion now follows straightforwardly by combining the equivalences f and g in the theorems 1.1.18 and 1.1.19. \square

1.1.24 Proposition: *Let P be a pointed polyhedron, $\mathcal{K}^u(P)$ the set of its unbounded faces. Let Q be the compact polytope “between two closures of P ”: If α is a linear form for P as in theorem 1.1.18, then $Q := P \cap \{\alpha \geq n\} \cap \{\alpha \leq n + 1\}$ for some n big enough.*

Then there is an order-preserving bijection f between $\mathcal{K}^u(P) \times \{1, 1', 2\}$ and $\mathcal{K}(Q)$ given by

$$\begin{aligned} f(F, 1) &= F \cap \{\alpha = n\} \\ f(F, 1') &= F \cap \{\alpha = n + 1\} \\ f(F, 2) &= \overleftarrow{f(F, 1)f(F, 1')}, \end{aligned}$$

where we set $(F, a) < (F, b)$ if $b = 2$ and $a \in \{1, 1'\}$.

Proof: We have already seen the order-preserving bijections between $\mathcal{K}^u(P) \times \{1\}$ and the associated complex of $P \cap \{\alpha = n\}$ as well as between $\mathcal{K}^u(P) \times \{1'\}$ and the associated complex of $P \cap \{\alpha = n + 1\}$. This is already enough to see injectivity and order-preservation of the whole function f . It remains to show surjectivity: Let F be a face of Q , $F \subsetneq \{\alpha = n\} \cup \{\alpha = n + 1\}$. Let H be the smallest face of P containing F . Then, by a repetition of arguments used similarly before (the main fact being that $\dim F = \dim H$), $F = H \cap \{\alpha \geq n\} \cap \{\alpha \leq n + 1\}$. \square

1.1.25 Corollary: *If P, P' are combinatorially equivalent pointed polyhedra, Q, Q' defined as above, then also Q, Q' are combinatorially equivalent.*

1.1.26 Proposition: *Let P, P' be pointed polyhedra and $f^c : P \rightarrow P'$ a combinatorial equivalence. Then there is a piecewise linear equivalence $f : P \rightarrow P'$ respecting the combinatorial equivalence, that is, $f(F) = f^c(F)$ for all faces F of P .*

Proof:

- a) We first consider the case that P, P' are compact: Let \tilde{K}, \tilde{K}' designate the barycentric subdivisions of P and P' , respectively. As P and P' are combinatorially equivalent, we know that there is an order-preserving bijection $\tilde{f} : \tilde{K} \rightarrow \tilde{K}'$. Define $f : P \rightarrow P'$ to be the piecewise linear map whose restriction on any simplex $\hat{P}_{i_0} \dots \hat{P}_{i_k} \in \tilde{K}$ is given by the (unique) affine linear map that maps all \hat{P}_{i_j} to $\tilde{f}(\hat{P}_{i_j})$. As the inverse of f can be constructed in the same way (interchanging the role of P and P'), f is a piecewise-linear equivalence.
- b) Now consider the case, P and P' are unbounded: Let α, α' designate linear forms for P, P' as in theorem 1.1.18, and $P_0 := P \cap \{\alpha \leq n\}$ and $P'_0 := P' \cap \{\alpha \leq n\}$ closures of P and P' respectively. Then define $P_i := P \cap \{\alpha \geq n+i-1\} \cap \{\alpha \leq n+i\}$ and $P'_i := P' \cap \{\alpha \geq n+i-1\} \cap \{\alpha \leq n+i\}$ for all $i \in \mathbb{N}$, $i \geq 1$. By Proposition 1.1.24 P_i and P'_i are combinatorially equivalent for all i , moreover we can assume that on $P_i \cap P_{i+1}$ the two equivalences coincide. So if we construct the piecewise linear equivalences between P_i and P'_i as in part a), these equivalences coincide on $P_i \cap P_{i+1}$ for all $i \in \mathbb{N}$. So we can put the maps together, which yields the required piecewise linear map $P \rightarrow P'$.

□

1.1.27 Theorem: *Let P be a pointed polyhedron, \bar{P} its closure and G its closing face. Then there is a p.l. equivalence $f' : P \rightarrow \bar{P} \setminus G$ respecting the combinatorial equivalence f from theorem 1.1.18, that is $f'(F) = f(F)$ for all faces F of P .*

Proof: The proof is very similar to the proof of the previous proposition. We use the same notation and define the P_i in the same way as there. We can assume that $\bar{P} = P \cap \{\alpha \leq n+1\}$. Let $a_i := \sum_{j=1}^i 2^{-j}$ for $i \in \mathbb{N}$ (thereby $a_0 = 0$). Then we define $P'_0 = P_0$

and for $i \geq 1$

$$P'_i := P \cap \{\alpha_i \geq a_{i-1}\} \cap \{\alpha \leq a_i\}.$$

As in the previous theorem P_i and P'_i are combinatorially and thus p.l. equivalent and we can put the p.l. equivalences together to form a p.l. map $f' : P \rightarrow \overline{P}$. By construction the image of this map is $\overline{P} \setminus G$, which concludes the proof. \square

Now we want to define closures of polyhedral complexes analogously to the closure of a single pointed polyhedron. There is no natural way to do this for arbitrary polyhedral complexes, but if the complex consists of copies of one single pointed polyhedron P which are glued along their faces, then the closure of P induces immediately a natural closure of the whole complex.

So from now on we will deal only with the following situation:

Let P be a pointed polyhedron and $I = \{1, \dots, r\}$ a finite set. For each facet F shall be given a function $g_F : I \rightarrow I$ with the property

$$g_F(i) = j \iff g_F(j) = i$$

(in other words, $g^2 = \text{id}$). Let K be the polyhedral complex consisting of all equivalence classes of $\mathcal{K}(P) \times I$ under the following equivalence relation:

For faces $F, F' \in \mathcal{K}(P)$

$$(F, i) \sim (F', j) \iff F = F' \text{ and there is a facet } \tilde{F} \text{ with } F \subset \tilde{F} \\ \text{such that } g_{\tilde{F}}(i) = j.$$

1.1.28 Definition: We define the *compactification* \overline{K} of K as the following complex: \overline{K} consists of all equivalence classes of $\mathcal{K}(\overline{P}) \times I$ under the same type of equivalence relation as before where we additionally set $g_G = \text{id}$, where G is the closing facet of P .

If X is the realization of K then we define \overline{X} to be the realization of \overline{K} .

Remark: We prefer the word “compactification” to “closure” here, because in the context of manifolds, the word “closed” has a slightly different meaning (compact and without boundary) from what is usual.

Remark: The complex \overline{K} is described only as abstract polyhedral complex, but it can be shown (see [RS]) that every such complex has a realization in \mathbb{R}^d for some d .

Example: Let $P = (\mathbb{R}_{\geq 0})^2$ as shown in figure 1.2. Multiplication with $(\pm 1, \pm 1)$ gives 4 copies $P^{(++)}$, $P^{(+-)}$, $P^{(-+)}$ and $P^{(--)}$, whose union, which can also be viewed as a glueing, is \mathbb{R}^2 . Designating the intersection of P with the x -axis with X , that with the y -axis with Y , we can describe the glueing with the function g given as

$$\begin{aligned} g_X(++) &= +- & g_X(+-) &= ++ & g_X(-+) &= -- & g_X(--) &= -+ \\ g_Y(++) &= -+ & g_Y(+-) &= -- & g_Y(-+) &= ++ & g_Y(--) &= +- \end{aligned}$$

(compare also figure 1.3). P is combinatorially equivalent and hence p.l. equivalent to a triangle with one facet removed. So, we identify P with the upper right triangle in figure 1.3 without the dotted line G . The triangle together with the dotted line is \overline{P} . The induced glueing (defined in the above notation by setting $g_G \equiv 1$) additionally glues only the points $X \cap G$ and $Y \cap G$, as well as their copies, as shown in the picture. So, the result is the p.l. 2-ball with a p.l. circle as boundary. The boundary is the result of the glueing of the copies of G .

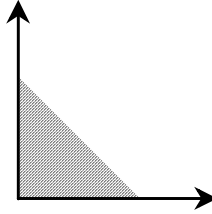
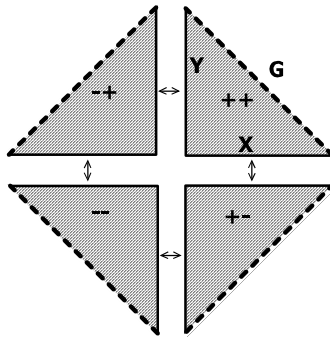
Figure 1.2: The positive orthant P Figure 1.3: Glueings of P and \bar{P}

1.1.29 Definition: Let X be a topological space. A *co-ordinate map* is a pair (f, P) , where P is a polyhedron and $f : P \rightarrow X$ is a homeomorphism onto its image. Two co-ordinate maps $(f, P), (g, Q)$ are called *compatible* if either $f(P) \cap g(Q) = \emptyset$ or there is a co-ordinate map (h, R) such that $h(R) = f(P) \cap g(Q)$ and $f^{-1} \circ h, g^{-1} \circ h$ are piecewise linear maps.

A *piecewise linear atlas* on X is a set \mathcal{A} of co-ordinate maps on X satisfying the following properties:

- (i) Any two $(f, P), (g, Q) \in \mathcal{A}$ are compatible,
- (ii) For all $x \in X$ there is a $(f, P) \in \mathcal{A}$ such that $f(P)$ is a neighbourhood of x in X .
- (iii) \mathcal{A} is maximal, that is if (f, P) is a co-ordinate map compatible to all $(g, Q) \in \mathcal{A}$, then $(f, P) \in \mathcal{A}$.

A *PL-manifold* (with or without boundary) of dimension n is a d -dimensional topological manifold (with or without boundary) with a p.l. atlas.

A map $F : X \rightarrow Y$ between PL-manifolds is called a *p.l. map* if for all $(f, P) \in \mathcal{A}, (g, Q) \in \mathcal{B}$, where \mathcal{A}, \mathcal{B} are the p.l. structures of X and Y respectively, either $F \circ f(P) \cap g(Q) = \emptyset$ or there is a coordinate map (h, R) for Y such that $h(R) = F \circ f(P) \cap g(Q)$ and $g^{-1} \circ h$ is a p.l. map. X, Y are *p.l. homeomorphic* if there are p.l. maps $F : X \rightarrow Y, G : Y \rightarrow X$ with $F \circ G = \text{id}_Y, G \circ F = \text{id}_X$.

We define the notions of *boundary* and *interior* of a PL-manifold as those of the underlying topological manifold. We recall that a manifold (p.l. or topological) is called *closed* if it is compact and has no boundary.

Remark: In short, a PL-manifold is a topological manifold X whose transition maps are piecewise linear maps. This is equivalent to asking that there is a triangulation on X (a homeomorphism from a simplicial complex) such that the link of each vertex of the triangulation is simplicially isomorphic to a p.l. sphere (i.e. there is a

subdivision of the link combinatorially equivalent to a subdivision of the sphere).

It is a natural question whether there is any difference between topological and p.l. manifolds. This question and other similar ones occupied topologists for over one half of a century. The answer involves many deep results and complicated methods. We will briefly expose the subject here and refer to [Rud] for a more detailed exposition.

The first question that arose in this context (around 1910) was whether two simplicial complexes which are homeomorphic must also be simplicially isomorphic. At first no counterexamples could be found, so it was conjectured to be true and got the name “Hauptvermutung der kombinatorischen Geometrie” or just “Hauptvermutung”. In 1961 J. Milnor found a 6-dimensional counterexample ([Mil]). This example was not a manifold, though, so the Hauptvermutung was renewed to hold for triangulated manifolds. S. Smale showed that the Hauptvermutung is true for all n -spheres provided $n \neq 4, 5, 7$ (see [Sma]). A weaker version was found to hold on all spheres. The Hauptvermutung for manifolds was finally disproved by J. Kirby and L. Siebenmann when they classified p.l. structures on topological manifolds of dimension at least 5 ([KS]) (a p.l. structure is a certain equivalence class of p.l. atlases, slightly weaker than p.l. isomorphism).

In order to give a complete picture of what happens on manifolds of various dimensions we consider also the third category of manifolds, namely differentiable (or smooth) manifolds, especially as nonsingular real algebraic varieties belong to that category:

For dimensions up to 3 there is no difference between topological, p.l. and differentiable manifolds. For dimensions ≤ 2 this was shown by Ch. Papakyriakopoulos ([Pap]), for dimension 3 by E. Moise ([Moi]). For topological manifolds X of dimension ≥ 5 the Kirby-Siebenmann classification states that there is an obstruction in $H^4(X, \mathbb{Z})$ to the existence of p.l. structures. If that obstruction vanishes, the p.l. structures are classified by $H^3(X, \mathbb{Z})$, so in particular there are only finitely many. The classifying space

for p.l. structures is an Eilenberg-MacLane space, whereas the classifying space for differentiable structures has many nontrivial homotopy groups. In dimensions 4 to 6 PL-manifolds and differentiable manifolds coincide, but from dimensions 7 on, one can roughly say that the concept of PL-manifolds is “close” to that of topological manifolds, whereas differentiable manifolds differ a lot (famous are the so-called “exotic 7-spheres” found also by Milnor). Topological 4-folds are “wild”, as there are examples, which admit infinitely many p.l. structures (and for many other reasons as well). Finally, a further difference between topological and differentiable manifolds is the fact that the latter ones can always be triangulated, whereas it is an open problem if the first ones can be (in dimension 4 there is a counterexample).

1.1.30 Proposition: *If X is a PL-manifold realized by glueing of copies of a polyhedron P as described above, then \overline{X} and $\partial\overline{X}$ are PL-manifolds, which are universal in the sense that, if Y is any (topological or PL-) manifold with $Y \setminus \partial Y \cong X$, then there are p.l. homeomorphisms of Y and ∂Y to submanifolds of \overline{X} and $\partial\overline{X}$, respectively. In particular, \overline{X} and $\partial\overline{X}$ are essentially unique as topological and PL-manifolds.*

Proof: If Y is a compact manifold with $Y \setminus \partial Y \cong X$, then the polyhedral subdivision on X given by the copies of Δ induces a polyhedral subdivision on Y and ∂Y whose combinatorial structure is already defined by the subdivision of X . This defines the asserted p.l. homeomorphisms.

Let $x \in \partial\overline{X}$ be a point and G a polytope of the subdivision such that $x \in \text{Int}(G)$. Then G is the closing face of some face F of Δ and the link of x is combinatorially equivalent to the link of any inner point of F . As X is a PL-manifold, hence so is $\partial\overline{X}$ and \overline{X} . \square

Remark: The uniqueness of \overline{X} does not necessarily hold in the category of differentiable manifolds: Milnor ([Mil]) presented an example of two 8-dimensional manifolds whose interior are diffeomorphic but whose boundaries are not.

1.2 Lattice Polytopes and Triangulations

This section is devoted to the concepts and tools around lattice polytopes and lattice triangulations. It includes the definition of dual and reflexive polytopes, the P - and the Q -polynomial of a lattice polytope as well as unimodular triangulations. It concludes with the investigation of certain groups and group homomorphisms, which are defined by lattice triangulations. They will be useful in later chapters for the description of toric varieties for combinatorial calculations in Viro's patchworking method.

1.2.1 Definition: A *lattice* is a discrete free abelian group of finite rank.

Remark: Every lattice is isomorphic to \mathbb{Z}^d , for some nonnegative integer d . In our applications the lattice will mostly be just \mathbb{Z}^d , as there will be no need for greater generality.

1.2.2 Definition: A *lattice equivalence* is a bijective affine linear map $f : \mathbb{R}^d \rightarrow \mathbb{R}^d$ such that $f(\mathbb{Z}^d) \subset \mathbb{Z}^d$.

A *lattice polytope* is a polytope $\Delta \subset \mathbb{R}^d$, such that all its vertices lie in \mathbb{Z}^d . We write $\Delta(i)$ for the set of i -dimensional faces of Δ .

We define

$$l(\Delta) := \#(\Delta \cap \mathbb{Z}^d),$$

$$l^*(\Delta) := \#(\text{Int}(\Delta) \cap \mathbb{Z}^d)$$

and

$$l^\partial(\Delta) := \#(\partial\Delta \cap \mathbb{Z}^d).$$

1.2.3 Definition: Let $\Delta \subset \mathbb{R}^d$ be a lattice polytope, such that $0 \in \text{Int}(\Delta)$. The *dual polytope* (or *polar polytope*) Δ^* is defined as

$$\Delta^* := \{x \in \mathbb{R}^d \mid \langle x, y \rangle \geq -1 \text{ for all } y \in \Delta\}.$$

Δ is called *reflexive* if Δ^* is again a lattice polytope.

If Γ is a proper face of Δ and Δ is reflexive, then

$$\Gamma^* := \{x \in \mathbb{R}^d \mid \langle x, y \rangle = -1 \text{ for all } y \in \Gamma\} \cap \Delta^*$$

is called the *dual face* of Γ .

1.2.4 Proposition: *Let Δ be a lattice polytope.*

- (i) $(\Delta^*)^* = \Delta$,
- (ii) Δ is reflexive $\iff \Delta^*$ is,
- (iii) Δ is reflexive if and only if there are no lattice points between $k\Delta$ and $(k+1)\Delta$ for any $k \in \mathbb{N}$,
- (iv) 0 is the only interior point of a reflexive polytope.
- (v) If Γ is a proper face of a reflexive polytope Δ , then $\dim \Gamma^* = \dim \Delta - 1 - \dim \Gamma$.

Proof: (i) and (ii) are easy to verify. For (iii), see [Hse], 2.2. (iv) follows from (iii) by setting $k = 0$.

(v) is easily verified, if Γ is a vertex of Δ . The general case then follows by noting that

$$\Gamma^* = \bigcap_{v \in \Gamma(0)} v^*.$$

□

1.2.5 Proposition: *Let Δ be a 3-dimensional reflexive polytope. For any face $\Gamma \in \Delta(1)$ let $\Gamma^* \in \Delta^*(1)$ denote the dual face. Then*

$$\sum_{\Gamma \in \Delta(1)} (l(\Gamma) - 1)(l(\Gamma^*) - 1) = 24.$$

Proof: It follows from [Bat], theorems 3.3.4 and 4.2.5 that the left hand side is the Euler characteristic of some complex K3 surface (constructed with the method described in Chapter IV). On the other hand, it is well-known (compare proposition 4.2.1) that the Euler characteristic of any complex K3 surface is 24. \square

Remark: The above proof using K3 surfaces is the only “nice” proof known to us. As the complete list of 3-dimensional reflexive polytopes is available today, a “brute-force” proof, which consists in checking on all examples, is of course also possible.

1.2.6 Definition: Let $\sigma \subset \mathbb{R}^d$ be a d -dimensional lattice simplex with vertices v_0, v_1, \dots, v_d . The *normalized volume* $\text{vol}_N(\sigma)$ is defined as the absolute value of the determinant of the $n \times n$ -matrix $(v_1 - v_0, \dots, v_d - v_0)$. For a simplicial complex K the normalized volume of $|K|$ is defined as $\text{vol}_N(|K|) = \sum_{\sigma \in K} \text{vol}_N(\sigma)$.

Remark: The normalized volume is invariant under lattice equivalences, as these are given as a composition of a translation (which obviously does not affect the normalized volume) and a linear map given by some $A \in GL(d, \mathbb{Z})$, which has determinant ± 1 .

Moreover, the euclidian volume and the normalized volume are related by $\text{vol}(\sigma) = \frac{1}{d!} \text{vol}_N(\sigma)$. As the normalized volume of the standard simplex is 1, it can be interpreted as “rescaling” of the euclidian volume so as to measure the volume in multiples of the smallest possible lattice simplex (of a fixed dimension).

1.2.7 Definition: A simplicial complex \mathcal{T} is called *d -dimensional* if d is the maximal dimension of its simplices and for all $v \in |\mathcal{T}|$ there is a d -dimensional simplex in \mathcal{T} containing v .

A *simplicial lattice complex* is a simplicial complex consisting of lattice simplices. It is called *maximal* if it cannot be further subdivided using lattice simplices. It is called *unimodular* if all simplices have normalized volume 1.

1.2.8 Definition: A *lattice triangulation* \mathcal{T} of a lattice polytope Δ is a simplicial lattice complex, such that the realization $|\mathcal{T}| = \Delta$. We will designate the induced triangulation on $\partial\Delta$ by $\partial\mathcal{T}$.

For $i = 0, \dots, d$ we will often write for commodity

$$\begin{aligned} f_i &:= \#\mathcal{T}(i), \\ f_i^\partial &:= \#\{\sigma \in \mathcal{T}(i) \mid \sigma \subset \partial\Delta\}, \\ f_i^* &:= \#\{\sigma \in \mathcal{T}(i) \mid \sigma \subset \text{Int}\Delta\}, \end{aligned}$$

where $\mathcal{T}(i)$ designates the set of i -dimensional simplices in \mathcal{T} . When we talk of *maximal* or *unimodular triangulations* of Δ we will automatically understand that they are lattice triangulations.

1.2.9 Proposition: Let \mathcal{T} be a simplicial lattice complex.

- a) \mathcal{T} is maximal if and only if for all $\sigma \in \mathcal{T}$, $\text{Int}(\sigma) \cap \mathbb{Z}^d = \emptyset$.
- b) If \mathcal{T} is unimodular, then it is maximal.
- c) If \mathcal{T} is maximal and $\dim|\mathcal{T}| \leq 2$, then it is also unimodular.
- d) The following are equivalent:
 - (i) \mathcal{T} is unimodular,
 - (ii) For all $\sigma \in \mathcal{T}$: The differences $v_1 - v_0, \dots, v_s - v_0$ are part of a \mathbb{Z} -basis of \mathbb{Z}^d (where v_0, v_1, \dots, v_s designate the vertices of σ),
 - (iii) For all $\sigma \in \mathcal{T}$: σ is lattice equivalent to the s -dimensional standard simplex.

Proof: In the proofs of a) - d) we may without loss of generality assume that \mathcal{T} consists of a single simplex σ of maximal dimension.

To a): Obviously, if σ has an inner lattice point there exists a subdivision of σ . Assume, on the other hand, that $\text{Int}(\sigma) = \emptyset$ and $\sigma' \subset \sigma$ is subsimplex of σ . The vertices of σ' must be vertices of σ

as well, as σ has no inner lattice point. But then σ' is a face of σ , so there does not exist a proper subdivision of σ .

To b): Obviously a simplex of normalized volume 1 cannot be truly subdivided by using lattice simplices, as the normalized volume is always an integer.

To c): This is obvious for $\dim \sigma \in \{0, 1\}$. So let $\dim \sigma = 2$. Without loss of generality we may assume that $(0, 0)$ and $(1, 0)$ are vertices of σ . If (a, b) is the third vertex, then we can apply the affine lattice transformation defined by $(u, v) \mapsto (-u + a, -v + b)$, which transforms σ into the lattice simplex with vertices $(0, 0)$, $(1, 0)$ and $(a - 1, b)$. This is minimal, too, so by repeating the argument we arrive at the simplex with vertices $(0, 0)$, $(1, 0)$ and $(0, b)$ (if we started with $a > 0$; if $a < 0$ a similar argument can be used). But then $b = \pm 1$ and $\text{vol}_N(\sigma) = 1$.

To d): Clearly (ii) and (iii) are equivalent. As the standard simplex has normalized volume 1, (iii) \rightarrow (i) is also evident. So assume now σ is a simplex of normalized volume 1. We may assume that v_0 is the origin, then the other vertices are a \mathbb{Q} -basis of $\mathbb{R}^{\dim \sigma}$. Let A be the transformation matrix to the standard basis of $\mathbb{R}^{\dim \sigma}$. Then $A \in \text{GL}(\dim \sigma, \mathbb{Z})$ if and only $|\det(A)| = 1$. But $|\det(A)|$ is also the normalized volume of σ , which concludes the proof. \square

1.2.10 Proposition: *Let \mathcal{T} be a lattice triangulation of a d -dimensional lattice polytope $\Delta \subset \mathbb{R}^d$ with $d \geq 1$. Then*

$$(d-1)f_d = -f_{d-1}^\partial + 2(f_{d-2} - f_{d-3} \pm \dots + (-1)^d f_0 - (-1)^d).$$

Proof: Any d -dimensional simplex has $d+1$ facets, whereas each $\sigma \in \mathcal{T}(d-1)$ is a facet of

- exactly two simplices of the triangulation if $\sigma \cap \text{Int}(\Delta) \neq \emptyset$,
- exactly one simplex of the triangulation if $\sigma \in \partial\Delta$.

So,

$$\begin{aligned}(d+1)f_d &= 2f_{d-1}^* + f_{d-1}^\partial \\ &= 2f_{d-1} - f_{d-1}^\partial.\end{aligned}$$

Eliminating the term with f_{d-1} by using $1 = \chi(\Delta) = \sum(-1)^i f_i$ yields the assertion. \square

1.2.11 Corollary: *Let Δ be a 2-dimensional lattice polytope. Then*

$$\text{vol}_N(\Delta) = l(\Delta) + l^*(\Delta) - 2.$$

Proof: Let \mathcal{T} be a maximal triangulation of Δ . Then \mathcal{T} is also unimodular, so $f_2 = \text{vol}_N(\Delta)$. Clearly, $f_0 = l(\Delta)$, so the above proposition yields

$$\begin{aligned}\text{vol}_N(\Delta) &= -\text{vol}_N(\partial\Delta) + 2l(\Delta) - 2 \\ &= -l^\partial(\Delta) + 2l(\Delta) - 2 \\ &= l(\Delta) + l^*(\Delta) - 2.\end{aligned}$$

\square

1.2.12 Definition: Let $\Delta \subset \mathbb{R}^d$ be a lattice polytope. We define the following two formal power series

$$\begin{aligned}\Phi(\Delta; t) &:= \sum_{i=0}^{\infty} \#(i\Delta \cap \mathbb{Z}^d) t^i \\ \Psi(\Delta; t) &:= \sum_{i=0}^{\infty} \#(\text{Int}(i\Delta) \cap \mathbb{Z}^d) t^i.\end{aligned}$$

We hereby set by convention $\text{Int}(0 \cdot \Delta) := \emptyset$. Φ is also called the *Ehrhart series* of Δ .

The additional convention is motivated by the idea that we are looking at the cone generated by $\Delta \times \{1\}$ and lattice points of “height” i . The origin is always a boundary point of this cone and thus should not occur in the calculation of Ψ .

These series are obviously invariant under lattice equivalences. They have the following properties:

1.2.13 Proposition: *Let Δ be a d -dimensional lattice polytope.*

a) $\Phi(\Delta; t)$ and $\Psi(\Delta; t)$ are rational functions of the form

$$\Phi(\Delta; t) = \frac{P(\Delta; t)}{(1-t)^{d+1}},$$

$$\Psi(\Delta; t) = \frac{Q(\Delta; t)}{(1-t)^{d+1}},$$

where P and Q are polynomials with nonnegative integer coefficients and of degree at most $d+1$.

b) $P(\Delta; t) = t^{d+1}Q(\Delta; t^{-1})$.

c) $P(\sigma^{(d)}; t) = 1$ (where $\sigma^{(d)}$ is the d -dimensional standard simplex).

d) Let \mathcal{T} be a unimodular triangulation of Δ . Then

$$P(\Delta; t) = (1-t)^{d+1} + \sum_{j=0}^d f_j t^{j+1} (1-t)^{d-j},$$

$$Q(\Delta; t) = (t-1)^{d+1} + \sum_{j=0}^d f_j (t-1)^{d-j}.$$

Proof: See [Hse], section 2.3. □

1.2.14 Corollary: For a unimodular triangulation \mathcal{T} of a lattice polytope the numbers $f_j = \#\mathcal{T}(j)$ are independent of the particular choice of triangulation for all $j \geq 0$.

Proof: Part (d) of proposition 1.2.13 shows that the numbers $\#\mathcal{T}(j)$ of a unimodular triangulation \mathcal{T} turn up as coefficients of the P -respectively the Q -polynomial (viewed as polynomials in $t - 1$). As the polynomials are defined independently of any triangulation, the $\#\mathcal{T}(j)$ must be independent, too. \square

1.2.15 Definition: A triangulation \mathcal{T} of a bounded polytope Δ is called *coherent* if it admits a strongly convex piecewise linear function on it, that is a convex function $\nu : \Delta \rightarrow \mathbb{R}$ such that $\nu|_{\sigma}$ is affine linear for all $\sigma \in \mathcal{T}$ and $\nu|_{\sigma} \neq \nu|_{\sigma'}$ for distinct $\sigma, \sigma' \in \mathcal{T}$.

1.2.16 Proposition: For any lattice polytope Δ there exists a coherent maximal lattice triangulation of Δ .

Proof: See [Hse], section 2.2. \square

Remark: Most “naturally arising” triangulations are indeed coherent. Examples for non-coherent triangulations can be seen in figure 1.4. It can be directly verified that these triangulations do not admit a strongly convex p.l. function, but it also follows elegantly from the following result.

1.2.17 Proposition: Let $\Delta \subset \mathbb{R}^d$ be a lattice polytope and \mathcal{T} a lattice triangulation of it. We define the characteristic function of \mathcal{T} by

$$\begin{aligned} \nu_{\mathcal{T}} : \mathcal{T}(0) &\rightarrow \mathbb{R} \\ v &\mapsto \sum_{\sigma \in \text{star}(v)} \text{vol}_N(\sigma). \end{aligned}$$

Then the map $\mathcal{T} \rightarrow \nu_{\mathcal{T}}$ is injective for coherent triangulations.

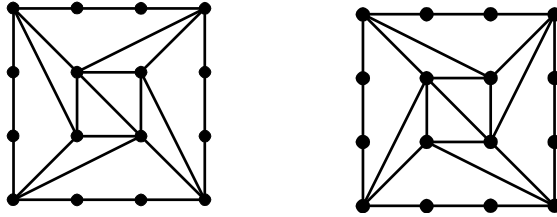

Figure 1.4: Non-coherent lattice triangulations

Proof: See [GKZ], theorem 1.7 of chapter 7. □

1.2.18 Corollary: *It is easy to check that the triangulations in figure 1.4 have the same characteristic functions. According to the proposition they cannot be coherent.*

Now we turn our attention to some groups defined by lattice polytopes, which will be useful in the following chapters.

1.2.19 Definition: For $v \in \mathbb{Z}^d$ we designate by \bar{v} the image of v in $(\mathbb{Z}/2\mathbb{Z})^d = (\mathbb{F}_2)^d$ by the projection map.

1.2.20 Definition: For any lattice simplex $\sigma \subset \mathbb{R}^d$ with vertices v_0, \dots, v_k we define $\text{Lin}_2(\sigma)$ to be the \mathbb{F}_2 -vector space generated by $\{\bar{v}_1 - \bar{v}_0, \dots, \bar{v}_k - \bar{v}_0\}$ and set

$$\dim_2 \sigma := \dim_{\mathbb{F}_2} \text{Lin}_2(\sigma).$$

For a simplicial lattice complex \mathcal{T} we define

$$\dim_2 \mathcal{T} := \dim_{\mathbb{F}_2} \sum_{\sigma \in \mathcal{T}} \text{Lin}_2(\sigma).$$

Let $\Delta \subset \mathbb{R}^d$ be a lattice polytope. Recall that $\text{Lin}(\Delta)$ is the linear subspace generated by $\{v - v_0 \mid v \in \Delta\}$, for any fixed $v_0 \in \Delta$.

1.2.21 Definition: We define

$$\text{Latt}(\Delta) := \text{Lin}(\Delta) \cap \mathbb{Z}^d$$

and

$$\mathbb{S}_\Delta := \text{Hom}(\text{Latt}(\Delta), \{\pm 1\}).$$

In the following we will write ξ^u instead of $\xi(u)$ for $\xi \in \mathbb{S}_\Delta$ and $u \in \text{Latt}(\Delta)$.

1.2.22 Proposition: *Let $\Delta \subset \mathbb{R}^d$ be a k -dimensional lattice polytope. Then*

$$\text{Latt}(\Delta) \cong \mathbb{Z}^k.$$

Proof: As Δ is rational, $\text{Lin}(\Delta) \cap \mathbb{Q}^d$ is a k -dimensional \mathbb{Q} -vector space. By proposition 1.2.30,

$$\text{Latt}(\Delta) = (\text{Lin}(\Delta) \cap \mathbb{Q}^d) \cap \mathbb{Z}^d \cong \mathbb{Z}^k.$$

□

Remark: \mathbb{S}_Δ is an abelian group and hence a \mathbb{Z} -module. The \mathbb{Z} -module structure is given by $a \cdot \xi(u) = (\xi(u))^a$. As the right hand side depends only on the residue class mod 2 of a , \mathbb{S}_Δ has a natural structure of \mathbb{F}_2 -vector space given by $\bar{a} \cdot \xi(v) = (\xi(v))^a$. Any group isomorphism of \mathbb{S}_Δ to some other group thus can also be considered as a \mathbb{Z} -module isomorphism as well as an isomorphism of \mathbb{F}_2 -vector spaces.

It is easy to verify that by choosing a \mathbb{Z} -basis for $\text{Latt}(\Delta)$ we can identify \mathbb{S}_Δ with the group $\{\pm 1\}^s$, where $s := \dim \text{Lin}(\Delta) = \dim \Delta$, setting

$$(\xi_1, \dots, \xi_s)(u) := \xi_1^{u_1} \dots \xi_s^{u_s},$$

where u_1, \dots, u_s are the coordinates of u in the chosen basis. This description justifies the notation introduced above.

1.2.23 Definition: For any lattice polytope $\Delta' \subset \Delta$ define

$$N_{\Delta/\Delta'} := \{\xi \in \mathbb{S}_\Delta \mid \xi \equiv 1 \text{ on } \text{Latt}(\Delta')\}.$$

1.2.24 Proposition: *The (group-, \mathbb{Z} -module-, \mathbb{F}_2 -vector space-) homomorphism*

$$\mathbb{S}_\Delta / N_{\Delta/\Delta'} \longrightarrow \mathbb{S}_{\Delta'}$$

induced by the restriction map is an isomorphism.

The proof will require some preliminary results, so we postpone it to the end of the section.

1.2.25 Corollary: $N_{\Delta/\Delta'}$ consists of $2^{\dim \Delta - \dim \Delta'}$ elements.

Proof: By the previous proposition

$$\begin{aligned} \dim_{\mathbb{F}_2} N_{\Delta/\Delta'} &= \dim_{\mathbb{F}_2} \mathbb{S}_\Delta - \dim_{\mathbb{F}_2} \mathbb{S}_{\Delta'} \\ &= \dim \text{Lin}(\Delta) - \dim \text{Lin}(\Delta') \end{aligned}$$

and the assertion follows immediately. \square

1.2.26 Corollary: For $\Delta' \subset \Delta$ there is a natural injection

$$\mathbb{S}_{\Delta'} \subset \mathbb{S}_\Delta.$$

Proof: By proposition 1.2.24 we can naturally identify $\mathbb{S}_{\Delta'}$ with the orthogonal complement of $N_{\Delta/\Delta'}$, which is a subspace of \mathbb{S}_Δ . \square

Any $w \in \text{Latt}(\Delta)$ defines a homomorphism $\mathbb{S}_\Delta \rightarrow \{\pm 1\}$ by $\xi \mapsto \xi^w$. As the latter is 1 for all $w \in 2\text{Latt}(\Delta)$, this defines a homomorphism $\text{Latt}(\Delta)/2\text{Latt}(\Delta) \rightarrow \text{Hom}(\mathbb{S}_\Delta, \{\pm 1\}) =: (\mathbb{S}_\Delta)^\vee$ which in fact turns out to be an isomorphism:

1.2.27 Proposition: *The map*

$$\begin{aligned} \text{Latt}(\Delta)/2\text{Latt}(\Delta) &\longrightarrow (\mathbb{S}_\Delta)^\vee \\ \bar{w} &\mapsto (\xi \mapsto \xi^w) \end{aligned}$$

is well-defined and an isomorphism (of groups and of \mathbb{F}_2 -vector spaces).

Proof: It is easy to verify that the homomorphism

$$\begin{aligned} \text{Latt}(\Delta) &\longrightarrow (\mathbb{S}_\Delta)^\vee \\ w &\mapsto (\xi \mapsto \xi^w) \end{aligned}$$

has kernel $2\text{Latt}(\Delta)$. Thus the map in the assertion is a well-defined injective homomorphism. As $\text{Latt}(\Delta)/2\text{Latt}(\Delta)$ and $(\mathbb{S}_\Delta)^\vee$ have the same number of elements (namely $2^{\dim \Delta}$), the map is also surjective. \square

1.2.28 Definition: Let $w \in \text{Latt}(\Delta)$. Then we define $\hat{w} \in \mathbb{S}_\Delta$ by setting

$$\hat{w}(u) := (-1)^{\langle u, w \rangle}.$$

Remark: If (w_1, \dots, w_s) are the coordinates of w in some \mathbb{Z} -basis of $\text{Latt}(\Delta)$, then $((-1)^{w_1}, \dots, (-1)^{w_s})$ are the coordinates of \hat{w} in the above described identification of \mathbb{S}_Δ with $\{\pm 1\}^s$.

The rest of the section is devoted to the proof of proposition 1.2.24.

Let V be a d -dimensional \mathbb{Q} -vector space.

1.2.29 Proposition: $v_1, \dots, v_k \in V$ are \mathbb{Q} -linearly independent if and only if they are \mathbb{Z} -linearly independent.

Proof: One direction is immediately clear: If v_1, \dots, v_k are \mathbb{Z} -linearly dependent, then they are also \mathbb{Q} -linearly dependent.

So now let's assume that v_1, \dots, v_k are \mathbb{Q} -linearly dependent, so that they fulfill an equation

$$a_1 v_1 + \dots + a_k v_k = 0$$

for some $a_i \in \mathbb{Q}$ not all equal to 0. Then there is a $d \in \mathbb{Z}$ such that $da_i \in \mathbb{Z}$ for all $i = 1, \dots, k$. From

$$(da_1)v_1 + \dots + (da_k)v_k = 0$$

follows that v_1, \dots, v_k are also \mathbb{Z} -linearly dependent. \square

1.2.30 Proposition: *Let V be a \mathbb{Q} -vector subspace of \mathbb{Q}^d with $\dim_{\mathbb{Q}} V = k$. Then*

$$V \cap \mathbb{Z}^d \cong \mathbb{Z}^k.$$

Proof: Clearly, $V \cap \mathbb{Z}^d$ is a lattice, so it is isomorphic to $\mathbb{Z}^{\tilde{k}}$ for some nonnegative integer \tilde{k} . According to the previous proposition there can be at most k \mathbb{Z} -linearly independent vectors in $V \cap \mathbb{Z}^d$, so it follows that $\tilde{k} \leq k$.

On the other hand, let $\{v_1, \dots, v_k\}$ be a \mathbb{Q} -basis of V . Then there is a $d \in \mathbb{Z}$, such that $dv_i \in \mathbb{Z}^d$ for all $i = 1, \dots, k$. As dv_1, \dots, dv_k are still linearly independent, $\tilde{k} \geq k$, which concludes the proof. \square

1.2.31 Proposition: *Let $V \subset \mathbb{Q}^d$ be a \mathbb{Q} -vector subspace and let $\{v_1, \dots, v_k\}$ be a \mathbb{Z} -basis of $V \cap \mathbb{Z}^d$. Then there are $v_{k+1}, \dots, v_d \in \mathbb{Z}^d$ such that $\{v_1, \dots, v_d\}$ is a \mathbb{Z} -basis of \mathbb{Z}^d .*

Proof: Without loss of generality we may assume that $\dim V = d-1$ (otherwise we can prove the statement inductively by considering a chain $V = V_0 \subset \dots \subset V_{d-\dim V} = \mathbb{Q}^d$ and $\dim V_{i-1} = \dim V_i + 1$). Then there exists a linear form α , such that $V = \{\alpha = 0\}$. Let $(a_1, \dots, a_d) \in \mathbb{Q}^d$ be the coordinates of α in the standard basis. By appropriate multiplication of α by a scalar in \mathbb{Q} we may assume that $(a_1, \dots, a_d) \in \mathbb{Z}^d$ and

$$\gcd(a_1, \dots, a_d) = 1.$$

But then, there exist $x_1, \dots, x_d \in \mathbb{Z}$ such that

$$a_1x_1 + \dots + a_dx_d = 1.$$

Let v_d be the vector with coordinates (x_1, \dots, x_d) . Then we claim that $\{v_1, \dots, v_d\}$ is a \mathbb{Z} -basis of \mathbb{Z}^d .

To verify this, we note first that $\{v_1, \dots, v_d\}$ is a \mathbb{Q} -basis of \mathbb{Q}^d (if $b_1v_1 + \dots + b_dv_d = 0$ for some $b_i \in \mathbb{Z}$, then by applying α we get that $b_d = 0$ and hence $b_i = 0$ for all $i = 1, \dots, d$). So, for any $v \in \mathbb{Z}^d$, there are $b_1, \dots, b_d \in \mathbb{Q}$ such that

$$v = b_1v_1 + \dots + b_dv_d.$$

Applying α to both sides we get

$$\begin{aligned} \alpha(v) &= \alpha(b_1v_1 + \dots + b_{d-1}v_{d-1}) + b_d\alpha(v_d) \\ &= b_d. \end{aligned}$$

As $\alpha(v) \in \mathbb{Z}$, so is b_d . With $v - b_dv_d \in V \cap \mathbb{Z}^d$, b_1, \dots, b_d must be integers as well. \square

1.2.32 Corollary: *Let $V \subset \mathbb{Q}^d$ be a vector subspace, A a \mathbb{Z} -module and $g \in \text{Hom}(V \cap \mathbb{Z}^d, A)$. Then there is an $h \in \text{Hom}(\mathbb{Z}^d, A)$ such that $h|_{V \cap \mathbb{Z}^d} = g$.*

Proof: Let v_1, \dots, v_k be a \mathbb{Z} -basis of $V \cap \mathbb{Z}^d$. By the previous proposition we can extend it to a \mathbb{Z} -basis of \mathbb{Z}^d , say $\{v_1, \dots, v_d\}$. Then the assertion follows by taking as h the homomorphism defined by

$$h(v_i) = \begin{cases} g(v_i), & i = 1, \dots, k, \\ 1, & i = k + 1, \dots, d. \end{cases}$$

\square

Proof of proposition 1.2.24: The restriction to $\text{Lin}(\Delta')$ defines a homomorphism $\mathbb{S}_\Delta \rightarrow \mathbb{S}_{\Delta'}$ with kernel $N_{\Delta/\Delta'}$. By corollary 1.2.32 the map is surjective, which shows the assertion. \square

II Toric Varieties

In the first section of this chapter we review some general concepts of the theory of toric varieties, which are independent of the base field. In the second section we concentrate on real toric varieties, with special consideration of topological results.

2.1 Toric Varieties over \mathbb{K}

In this section we mainly follow the article of Danilov in [Dan]. The theory of toric varieties over the complex numbers can also be found in the textbooks [Ful] and [Oda].

Throughout this chapter let \mathbb{K} be an arbitrary field, d a non-negative integer, N a d -dimensional lattice and M its dual. Let $N_{\mathbb{R}} := N \otimes_{\mathbb{Z}} \mathbb{R}$ and $M_{\mathbb{R}} := M \otimes \mathbb{R}$ denote the real vector spaces generated by the respective lattices.

2.1.1 Definition: Let Σ be a finite collection of rational, polyhedral cones with the following properties:

- (i) All cones $\sigma \in \Sigma$ are strongly convex, that is, $\sigma \cap -\sigma = 0$.
- (ii) If τ is a face of σ and $\sigma \in \Sigma$, then $\tau \in \Sigma$.
- (iii) For all $\sigma, \tau \in \Sigma$: $\sigma \cap \tau$ is a common face of both σ and τ .

Σ is called a *fan* in $N_{\mathbb{R}}$.

Σ is called *smooth*, if all its cones are smooth, that is, any $\sigma \in \Sigma$ is generated by a part of a \mathbb{Z} -basis of N . If the generators of any $\sigma \in \Sigma$ are part of a basis of $N_{\mathbb{R}}$, then Σ is called *simplicial*.

The set

$$\text{supp}(\Sigma) := \bigcup_{\sigma \in \Sigma} \sigma$$

is called the *support* of Σ . Σ is *complete* if $\text{supp}(\Sigma) = N_{\mathbb{R}}$.

We say that Σ is *k-dimensional*, if all its maximal cones are *k-dimensional*.

2.1.2 Definition: Let Σ be a fan in $N_{\mathbb{R}}$. For any $\sigma \in \Sigma$ let

$$\sigma^{\vee} := \{m \in M \mid \langle m, v \rangle \geq 0 \forall v \in \sigma\}$$

denote the dual cone. We define the *affine toric variety associated with σ* to be

$$X_{\sigma} := \text{Spec } \mathbb{K}[\sigma^{\vee} \cap M].$$

Its (\mathbb{K} -valued) points are the morphisms $\text{Spec } \mathbb{K} \rightarrow X_{\sigma}$, which are given by homomorphisms of semigroup $\sigma^{\vee} \cap M \rightarrow \mathbb{K}$.

For two cones $\sigma \subset \tau$, the induced map $X_{\sigma} \rightarrow X_{\tau}$ is an open immersion (see [Dan], 2.6.1) and the map $X_{\sigma} \rightarrow X_{\tau} \rightarrow X_{\omega}$ for $\sigma \subset \tau \subset \omega$ is the same as $X_{\sigma} \rightarrow X_{\omega}$. Thus, for a fan Σ , the affine toric varieties X_{σ} , $\sigma \in \Sigma$, glue to form an abstract algebraic variety X_{Σ} , which is called the *toric variety associated with Σ* .

Remark: The definition of X_{σ} is justified by the fact that $\mathbb{K}[\sigma^{\vee} \cap M]$ is indeed a reduced finitely generated \mathbb{K} -algebra (see e.g. [Dan], 1.3).

For the moment we distinguish between the points of a toric variety and the variety itself, which is somewhat more than just the set of its points. For algebraically closed base fields the difference is not decisive as there is a 1-1-correspondence between closed points of the variety (i.e. maximal ideals of $\mathbb{K}[\sigma^{\vee} \cap M]$) and \mathbb{K} -points defined as above (and hence for $\mathbb{K} = \mathbb{C}$ we find one type of definition in [Oda] and the other one in [Ful]). For non-algebraically closed fields the distinction becomes necessary as the \mathbb{K} -points become “relatively few” in comparison to the closed points of the spectrum.

The language of spectra is universal and therefore well adopted for treating algebraic problems independently of the base field. For topological considerations though (when the base field carries a topology, like e.g. $\mathbb{K} = \mathbb{R}$ or $\mathbb{K} = \mathbb{C}$), it is more natural to look at \mathbb{K} -points only.

As in the end our aim are topological questions, we will finally adopt the latter view. Only in this particular section, where we introduce some basic concepts which are rooted in the fundamental relation between the algebraic aspects of toric varieties and convex geometry, we rely mainly on the spectra definition. We will parallelly explain how these concepts work out on the level of points where it seems appropriate to us.

Our first comment of this type concerns the above mentioned open immersion $X_\sigma \rightarrow X_\tau$ for cones $\sigma \subset \tau$: The inclusion map of the points is given by the restriction of $\text{Hom}(\sigma^\vee \cap M, \mathbb{K})$ to $\tau^\vee \cap M$.

2.1.3 Proposition: *Let X_Σ be a toric variety. Then*

- (i) $\dim X_\Sigma = d$,
- (ii) X_Σ is a normal algebraic variety,
- (iii) X_Σ is smooth if and only if Σ is smooth,
- (iv) X_Σ is complete if and only if Σ is complete.

Proof: The first assertion follows from the next proposition as

$$\dim X_\Sigma = \dim \text{Spec } \mathbb{K}[M] = \dim_{\mathbb{R}} M_{\mathbb{R}} = d.$$

For the other assertions, see [Dan]. □

2.1.4 Proposition: *For any fan Σ in $N_{\mathbb{R}}$ the toric variety X_Σ contains the algebraic torus*

$$\mathbb{T} := \text{Spec } \mathbb{K}[M]$$

as open, dense subvariety. The action of the torus on itself by multiplication extends to an algebraic action on X_Σ . Locally, on X_σ , it is given by the map

$$\begin{aligned} \mathbb{K}[\sigma^\vee \cap M] &\rightarrow \mathbb{K}[M] \otimes \mathbb{K}[\sigma^\vee \cap M] \\ u &\mapsto u \otimes u \end{aligned}$$

for $u \in \sigma^\vee \cap M$. For $\sigma \in \Sigma$ let

$$O_\sigma := \text{Spec } \mathbb{K}[\sigma^\perp \cap M],$$

which is embedded as subvariety of X_σ and hence of X_Σ via the projection map $\sigma^\vee \cap M \rightarrow \sigma^\perp \cap M$ which maps u to 1 if $u \in \sigma^\perp \cap M$ and to 0 otherwise.

O_σ is an algebraic torus of dimension $d - \dim \sigma$ and the different O_σ , for $\sigma \in \Sigma$, are exactly the orbits of the \mathbb{T} -action. The closure \overline{O}_σ is the union of all O_τ , $\tau \in \Sigma$, with $\sigma \subset \tau$ and is itself again a toric variety (with lattices $M \cap \sigma^\perp$ and its dual).

On the level of points the torus action can be described explicitly: For $t \in \text{Hom}(M, \mathbb{K}) \cong (\mathbb{K}^*)^d$, the action on some $x \in \text{Hom}(\sigma^\vee \cap M, \mathbb{K})$ is given by

$$(t \cdot x)(u) := t(u)x(u).$$

For each $\sigma \in \Sigma$ we define $x_\sigma \in X_\sigma$ as

$$x_\sigma(u) := \begin{cases} 1, & u \in \sigma^\perp, \\ 0 & \text{otherwise.} \end{cases}$$

Then, for all $\sigma \in \Sigma$, $x_\sigma \in O_\sigma$ and hence $O_\sigma = \mathbb{T} \cdot x_\sigma$. Its points can be identified with $(\mathbb{K}^*)^{d - \dim \sigma}$.

Proof: See [Dan] and [Ful]. □

2.1.5 Definition: Let N, N' be two lattices and Σ, Σ' fans in $N_\mathbb{R}, N'_\mathbb{R}$. A toric morphism $X_\Sigma \rightarrow X_{\Sigma'}$ is the morphism induced by a lattice homomorphism $\varphi : N \rightarrow N'$ such that for any $\sigma \in \Sigma$ there is a $\sigma' \in \Sigma'$ with $\varphi(\sigma) \subset \sigma'$.

2.1.6 Proposition: *A toric morphism φ commutes with the torus action, that is*

$$\varphi(t \cdot x) = \varphi(t) \cdot \varphi(x)$$

for all $t \in \mathbb{T}, x \in X_\Sigma$.

Proof: φ induces a lattice homomorphism $M' \rightarrow M$ and a \mathbb{K} -algebra homomorphism $\tilde{\varphi} : \mathbb{K}[(\sigma')^\vee \cap M'] \rightarrow \mathbb{K}[(\sigma)^\vee \cap M]$ for all σ' in Σ' . The proof now follows from a commuting diagram mainly stating that the map $u \mapsto u' \mapsto u' \otimes u'$ is equal to $u \mapsto u \otimes u \mapsto u' \otimes u'$, where $u' = \tilde{\varphi}(u)$. \square

Remark: The map $\Sigma \rightarrow X_\Sigma$ defines a covariant functor from the category of fans (with the above described lattice homomorphisms as morphisms) and the category of normal algebraic varieties that contain an algebraic torus as open, dense subset such that the action of the torus on itself extends to the whole variety. The morphisms are taken to be lattice homomorphisms mapping cones into cones respectively toric morphisms. This functor defines in fact an equivalence of categories, so any such algebraic variety X is of the form X_Σ (and M is the lattice of characters of the algebraic torus).

In the following we will present some facts about divisors, invertible sheaves and line bundles on toric varieties. Before doing so, we briefly review the general concepts. These can be found e.g. in [Hart]. To simplify things slightly, we will assume that X is a normal algebraic variety (this includes toric varieties).

A *Weil divisor* D on X is a formal sum $D = \sum n_i Y_i$, where the Y_i are irreducible closed subvarieties of X of codimension 1, and $n_i \in \mathbb{Z}$ with only finitely many different from zero.

A rational function f on X defines a Weil divisor in the following way: Let Y_1, \dots, Y_r be the irreducible components of the zero set of

f with multiplicities n_1, \dots, n_r and Z_1, \dots, Z_s the irreducible components of the pole set of f with multiplicities m_1, \dots, m_s . Then the divisor $(f) := \sum n_i Y_i - \sum m_j Z_j$ is called a *principal divisor*.

The group of Weil divisors modulo principal divisors is called the *divisor class group* and denoted by $\text{Cl}(X)$.

The concept of divisor classes can be generalized to subvarieties of arbitrary dimensions. The resulting groups are called Chow groups; in this sense $\text{Cl}(X)$ is the same as the Chow group $A_{d-1}(X)$.

A *Cartier divisor* is a locally principal Weil divisor, that is a Weil divisor D , such that there exists an open covering \mathcal{U} of X such that $D|_U$ is principal for each $U \in \mathcal{U}$.

A Cartier divisor can be given by the following data: an open covering \mathcal{U} of X and rational functions f_U for each $U \in \mathcal{U}$, such that $\frac{f_U}{f_V} \in \mathcal{O}_X^*(U \cap V)$ for all $U, V \in \mathcal{U}$.

If X is smooth, then the respective groups of Weil and Cartier divisors are isomorphic.

The group of Cartier divisors modulo principal divisors is denoted by $\text{CaCl}(X)$.

An *invertible sheaf* is a locally free \mathcal{O}_X -module of rank 1. The group of isomorphism classes of invertible sheaves with the tensor product as group operation is called the *Picard group* of X and denoted by $\text{Pic}(X)$.

Let D be a Cartier divisor, given by an open covering \mathcal{U} and rational functions f_U . Then D defines an invertible sheaf $\mathcal{L}(D)$ by setting $\mathcal{L}(D)(U) := f_U^{-1} \mathcal{O}_X(U)$ for all $U \in \mathcal{U}$. The map $D \mapsto \mathcal{L}(D)$ defines a group isomorphism $\text{CaCl}(X) \rightarrow \text{Pic}(X)$.

A line bundle \mathcal{L} on X is said to be *generated by global sections* if there are global sections $s_i \in \mathcal{L}(X)$ such that for all $x \in X$ the images of the s_i generate \mathcal{L}_x as \mathcal{O}_x -module. \mathcal{L} is *very ample* if \mathcal{L} admits a finite set of global section s_0, \dots, s_n such that the morphism $X \rightarrow \mathbb{P}^n$, $x \mapsto [s_0(x) : \dots : s_n(x)]$ is an embedding. \mathcal{L} is *ample* if $\mathcal{L}^{\otimes m}$ is very ample for some $m > 0$.

A line bundle over X is an algebraic variety Y together with a morphism $\pi : Y \rightarrow X$, such that there is an open covering \mathcal{U} of X and isomorphisms $\varphi_U : \pi^{-1}(U) \rightarrow U \times \mathbb{A}^1$ for all $U \in \mathcal{U}$, such

that $\varphi_V \circ \varphi_U^{-1} : U \cap V \times \mathbb{A}^1 \rightarrow U \cap V \times \mathbb{A}^1$ is given by $(x, y) \mapsto (x, f_{UV}(x)y)$ with $f_{UV} \in \mathcal{O}_X^*(U \cap V)$ (in other words $\varphi_V \circ \varphi_U^{-1}$ is induced by the map $\mathcal{O}_X(U \cap V)[y] \rightarrow \mathcal{O}_X(U \cap V)[y], y \mapsto f_{UV}(y)$). Two line bundles $\pi : Y \rightarrow X, \pi' : Y' \rightarrow X$ with transition functions $\{f_{UV}\}, \{f'_{UV}\}$ (by refinement we can assume that the coverings are identical) are isomorphic if there are $g_U \in \mathcal{O}_X^*(U)$ for all $U \in \mathcal{U}$ such that $f_{UV}f'_{UV}^{-1} = g_U g_V^{-1}$ for all $U, V \in \mathcal{U}$.

Let \mathcal{E} be an invertible sheaf on X , D a Cartier divisor such that $\mathcal{E} \cong \mathcal{L}(D)$. Let \mathcal{U} be an open covering of X and D be represented by rational functions f_U for $U \in \mathcal{U}$. Let Y be the (abstract) algebraic variety defined by the covering $\{U \times \mathbb{A}^1 \mid U \in \mathcal{U}\}$ and isomorphisms $U \times \mathbb{A}^1 \supset U \cap V \times \mathbb{A}^1 \rightarrow U \cap V \times \mathbb{A}^1 \subset V \times \mathbb{A}^1$, given by $(x, y) \mapsto (x, f_U f_V^{-1}(x)y)$ (the isomorphisms are induced by the maps $\mathcal{O}_V(U \cap V)[y] \rightarrow \mathcal{O}_U(U \cap V)[y], y \mapsto f_U f_V^{-1}y$). Then Y with the natural projection to X is a line bundle that does not depend (up to isomorphism) on the choice of D and its representation. The described assignment yields a 1-1 correspondence between isomorphism classes of invertible sheaves and isomorphism classes of line bundles.

Now we turn to toric varieties. **We will from now on assume that the 1-dimensional cones of Σ generate $N_{\mathbb{R}}$ as a real vector space.** Furthermore in our notation we will not distinguish rays and the first lattice point lying on them. In the given context it will always be clear what is meant.

2.1.7 Definition: A \mathbb{T} -stable Weil divisor on X_{Σ} is a divisor that remains invariant under the torus action. For $\rho \in \Sigma(1)$ let

$$D_{\rho} := \overline{O}_{\rho}$$

designate the corresponding \mathbb{T} -stable divisors.

2.1.8 Proposition: a) *The set $\{D_{\rho} \mid \rho \in \Sigma(1)\}$ is equal to the set of all different \mathbb{T} -stable irreducible closed subvarieties of X_{Σ} of codimension 1. So D is a \mathbb{T} -stable Weil divisor on X_{Σ} if and*

only if $D = \sum_{\rho \in \Sigma(1)} a_\rho D_\rho$ for some $a_\rho \in \mathbb{Z}$. The piecewise linear function ψ_D on $N_{\mathbb{R}}$ defined by

$$\psi_D(\rho) = -a_\rho$$

and linear continuation is called the *support function* of D and also characterizes D uniquely.

- b) The images of the \mathbb{T} -stable Weil divisors generate the divisor class group, respectively the Chow group $A_{d-1}(X_\Sigma)$.
- c) There is an exact sequence

$$0 \longrightarrow M \longrightarrow \bigoplus_{\rho \in \Sigma(1)} \mathbb{Z} \longrightarrow A_{d-1}(X) \longrightarrow 0 \quad (*)$$

and a related sequence of real vector spaces

$$0 \longrightarrow M_{\mathbb{R}} \xrightarrow{\alpha} \mathbb{R}^r \xrightarrow{\beta} A_{d-1}(X) \otimes_{\mathbb{Z}} \mathbb{R} \longrightarrow 0, \quad (*')$$

where $r = \#\Sigma(1)$.

Proof: a) is clear from the definitions. b) follows from c) with a). For c), see [Ful], section 3.4, which works for arbitrary fields as well. \square

2.1.9 Proposition: *If X_Σ is smooth, then the divisor*

$$\sum_{\rho \in \Sigma(1)} -D_\rho$$

defines a canonical divisor.

Proof: See [Dan], 6.6. \square

2.1.10 Proposition: a) A Weil divisor $D = \sum a_\rho D_\rho$ is a Cartier divisor if and only if there is a sequence $(m_\sigma)_{\sigma \in \Sigma}$ with $m_\sigma \in M$, such that $m_\sigma - m_{\sigma'} \in (\sigma \cap \sigma')^\perp$ for all $\sigma, \sigma' \in \Sigma$ and $a_\rho = \langle m_\rho, \rho \rangle$. Two sequences $(m_\sigma)_\sigma, (m'_\sigma)_\sigma$ define the same Cartier divisor if and only if $m_\sigma - m'_\sigma \in \sigma^\perp$ for all $\sigma \in \Sigma$.

b) The images of the \mathbb{T} -stable Cartier divisors generate the Cartier divisor class group $\text{CaCl}(X_\Sigma) \cong \text{Pic}(X_\Sigma)$.

Proof: See [Dan], 6.1 and 6.2. □

2.1.11 Definition: Let $D = \sum_{i=1}^r a_i \rho_i$ be a \mathbb{T} -stable Weil divisor on X_S . We define a (possibly empty) convex polyhedron

$$\begin{aligned} \Delta &:= \{m \in M_{\mathbb{R}} \mid \langle m, \rho_i \rangle \geq -a_i \forall i\} \\ &= \{m \in M_{\mathbb{R}} \mid m \geq \psi_D \text{ on } \text{supp}(D)\}. \end{aligned}$$

2.1.12 Definition: Let $\Delta \subset M_{\mathbb{R}}$ be a rational polyhedron with $0 \in \Delta$. With each face Γ of Δ we associate a cone $\sigma_\Gamma \subset N_{\mathbb{R}}$ defined by

$$\sigma_\Gamma := \{v \in N_{\mathbb{R}} \mid \langle u, v \rangle \leq \langle u, v' \rangle \text{ for all } u \in \Gamma, u' \in \Delta\}.$$

The set $\Sigma_\Delta := \{\sigma_\Gamma \mid \Gamma \text{ is a face of } \Delta\}$ is a fan, which is called the *normal fan* of Δ . We write X_Δ instead of X_{Σ_Δ} for the associated toric variety.

2.1.13 Proposition: Let X be a complete toric variety. Then X is projective if and only if there exists an ample line bundle on X .

Let $\mathcal{L} = \mathcal{L}(D)$ be a line bundle on X . The following are equivalent:

- (i) \mathcal{L} is ample,
- (ii) ψ_D is strictly convex,

(iii) Δ has nonempty interior

In this situation Δ is dual to Σ in the sense that there is an inclusion-reversing bijection between faces of Δ and cones of Σ . Furthermore, \mathcal{L} is generated by global sections with $H^0(X, \mathcal{L}) = \mathbb{K}[\Delta \cap M]$.

Proof: For the first statement see [Hart], theorem 7.6 of chapter II. For i) \Rightarrow ii) see [Dan], proposition 6.9.1, together with its subsequent remark. The equivalence ii) \Rightarrow iii) as well as the duality of Δ and Σ are easy exercises. The last statement is [Dan], 6.3. \square

Remark: The proposition also holds for non-complete toric varieties which are defined by a rational polyhedron Δ by replacing “projective” with “quasi-projective” (apart from the last statement), as there is a natural inclusion $X_\Delta \subset X_{\overline{\Delta}}$.

In dimensions up to 2, every complete toric variety is projective. But in dimension 3 there are complete fans that do not admit strictly convex support functions (they are closely related to non-coherent triangulations of 2-dimensional polytopes).

2.1.14 Proposition: Let $\Sigma \subset \mathbb{R}^d$ be a smooth fan and X the corresponding toric variety. Let \mathcal{L} be an invertible sheaf on X . Then the corresponding line bundle Y can be constructed as toric variety in the following way:

Let $D = \sum a_\rho \rho$ be a Cartier divisor such that $\mathcal{L} = \mathcal{L}(D)$ and $\nu = -\psi_D$, where ψ_D is the support function of D (so $\nu(\rho) = a_\rho$). Let $\rho_0 = (0, \dots, 0, 1) \in N \times \mathbb{Z}$. For each $\sigma \in \Sigma$ let $\tilde{\sigma}$ be the cone generated by the graph of $\nu|_\sigma$ and ρ_0 . Then we define $\tilde{\Sigma} := \{0\} \cup \{\tilde{\sigma} \mid \sigma \in \Sigma\}$ and Y to be the corresponding toric variety. The bundle map $Y \rightarrow X$ is induced by the projection map $\mathbb{Z}^d \times \mathbb{Z} \rightarrow \mathbb{Z}^d$ (mapping each $\tilde{\sigma}$ to σ).

Proof: For all $\sigma \in \Sigma$ let f_σ be the rational function defined by ν (i.e. for all generators ρ of σ , f_σ has a pole of order $\nu(\rho)$ along O_ρ). f_σ corresponds to $u_\sigma \in \mathbb{Z}^d$ with $\langle u_\sigma, \rho \rangle = \nu(\rho)$ for all ρ .

We have to show the following:

- (1) For all $\sigma \in \Sigma$ there is an isomorphism $\varphi_\sigma : U_{\tilde{\sigma}} \rightarrow U_\sigma \times \mathbb{A}^1$.
 (2) For all $\sigma, \sigma' \in \Sigma$

$$\varphi_{\sigma'} \circ \varphi_\sigma^{-1} : U_{\sigma' \cap \sigma} \times \mathbb{A}^1 \rightarrow U_{\sigma \cap \sigma'} \times \mathbb{A}^1$$

$$\text{is given by} \quad (x_1, \dots, x_d, y) \mapsto (x_1, \dots, x_d, \frac{f_\sigma}{f_{\sigma'}} y).$$

These conditions are equivalent to the following ones:

(1') For all $\sigma \in \Sigma$ there is an isomorphism $\psi_\sigma : \mathbb{R}[\sigma^\vee \cap \mathbb{Z}^d][y] \rightarrow \mathbb{R}[\tilde{\sigma}^\vee \cap \mathbb{Z}^d \times \mathbb{Z}]$.

(2') For all $\sigma, \sigma' \in \Sigma$

$$\psi_{\sigma'}^{-1} \circ \psi_\sigma : \mathbb{R}[(\sigma \cap \sigma')^\vee \cap \mathbb{Z}^d][y] \rightarrow \mathbb{R}[(\sigma' \cap \sigma)^\vee \cap \mathbb{Z}^d][y]$$

$$\text{is given by} \quad y \mapsto \frac{f_\sigma}{f_{\sigma'}} y$$

and the identity on $\mathbb{R}[(\sigma \cap \sigma')^\vee \cap \mathbb{Z}^d]$.

Let $\tilde{\sigma}$ be any cone of $\tilde{\Sigma}$. Let ρ_1, \dots, ρ_s be the generators of σ . As Σ is smooth, they are part of a \mathbb{Z} -basis of \mathbb{Z}^d . Without loss of generality we may assume that σ is full-dimensional, that is, $s = d$ (otherwise we restrict to the s -dimensional sublattice generated by ρ_1, \dots, ρ_s). Then σ^\vee is generated by the dual basis $\hat{\rho}_1, \dots, \hat{\rho}_d$.

It is easy to verify that $\tilde{\sigma}^\vee$ is generated by $\hat{\rho}_1 \times \{0\}, \dots, \hat{\rho}_d \times \{0\}$ and $\tau - \sum_{i=1}^d \nu(\rho_i) \hat{\rho}_i$ (as it is the dual basis to the generators of $\tilde{\sigma}$ and $\tilde{\Sigma}$ is also smooth). So obviously

$$\begin{aligned} \mathbb{R}[\sigma^\vee \cap \mathbb{Z}^d][y] &= \mathbb{R}[\hat{\rho}_1, \dots, \hat{\rho}_d][y] \\ &\cong \mathbb{R}[\hat{\rho}_1 \times \{0\}, \dots, \hat{\rho}_d \times \{0\}, \tau - \sum_{i=1}^d \nu(\rho_i) \hat{\rho}_i] \\ &= \mathbb{R}[\tilde{\sigma}^\vee \cap \mathbb{Z}^{d+1}], \end{aligned}$$

which proves (1) resp. (1').

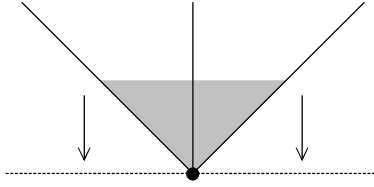
Figure 2.5: The anticanonical bundle over $\mathbb{P}^1 \times \mathbb{P}^1$

Now let $\tilde{\sigma}, \tilde{\sigma}' \in \tilde{S}$.

$$\begin{aligned} \psi_{\sigma}^{-1} \circ \psi_{\sigma'}(y) &= \psi_{\sigma}^{-1} \left(\tau - \sum_{i=1}^d \nu(\rho'_i) \hat{\rho}'_i \right) = \psi_{\sigma}^{-1} \left(\tau - \sum_{i=1}^d \nu(\rho_i) \hat{\rho}_i + u_{\sigma} - u_{\sigma'} \right) \\ &= y \frac{f_{\sigma}}{f_{\sigma'}}, \end{aligned}$$

which shows (2) resp. (2'). □

Example: Let $\Sigma \subset \mathbb{R}^d$ be a smooth fan. Then $D := \sum_{\rho \in \Sigma(1)} \rho$ defines an anticanonical divisor (that is, $-D$ is a canonical divisor). The corresponding bundle is a toric variety with fan Σ' with “all cones lifted up by one” (see figure 2.5). More precisely, there is an inclusion-preserving bijection $\Sigma \rightarrow \Sigma' \setminus \{0\}$ mapping a σ with generators ρ_1, \dots, ρ_s to $\rho_1 \times e_{d+1}, \dots, \rho_s \times e_{d+1}$. In particular, all generators of rays of Σ' lie on the hyperplane $\{u_{d+1} = 1\}$.

2.2 Real Toric Varieties

While in the last section we investigated those properties of toric varieties which are independent of the base field, in this section we will show some particular properties of toric varieties over \mathbb{R} . In the following we will be mainly interested in the topological aspects of the point set of the varieties. We therefore restrict and simplify

our view from now on by **identifying a toric variety with its point set** (as a topological space). So, in the following, by “real toric variety” we designate the set of real points of a toric variety over \mathbb{R} (see also the definition below). For the complex numbers we adopt the same terminology. Anyway, as mentioned before, the distinction between the variety and its points is in this case merely irrelevant.

For algebraic notions as divisors, projectivity etc. we will still refer to the concepts explained in the last section (e.g., a divisor “is” still a p.l. map on the fan, projectivity is given if and only if the toric variety can be assigned to a bounded rational polytope etc.).

2.2.1 Definition: The *real affine toric variety* assigned to a cone $\sigma \subset N_{\mathbb{R}}$ is defined to be

$$X_{\sigma} := \text{Hom}(\sigma^{\vee} \cap M, \mathbb{R}),$$

where “Hom” designates homomorphisms of semigroups.

If $\Sigma \subset N$ is a fan, then the *real toric variety* assigned to Σ is defined to be the algebraic variety obtained through an open cover $\{X_{\sigma}\}_{\sigma \in \Sigma}$, where $X_{\sigma} \cap X_{\tau}$ is identified with $X_{\sigma \cap \tau}$ ($X_{\sigma \cap \tau}$ is naturally included in both X_{σ} and X_{τ}).

Remark: The above definition works analogously for any semigroup instead of \mathbb{R} . Substituting \mathbb{R} by $\mathbb{R}_{\geq 0}$ we get a subset X_{Σ}^{+} of X_{Σ} , which can be identified with the quotient space of X_{Σ} under the action of the compact torus $\text{Hom}(M, \{\pm 1\})$.

As an other application, we get a natural inclusion of the real toric variety $X_{\Sigma, \mathbb{R}}$ into the complex toric variety $X_{\Sigma, \mathbb{C}}$, where it can be identified with the fixed point set of the complex conjugation.

For any real toric variety there is an action of the algebraic torus $\mathbb{T}_N := \text{Hom}(M, \mathbb{R}) \cong (\mathbb{R}^*)^d$ by multiplication:

$$t \cdot x(u) := t(u)x(u),$$

where x is an element of some X_σ . For each $\sigma \in \Sigma$ we define

$$x_\sigma(u) := \begin{cases} 1, & u \in \sigma^\perp, \\ 0 & \text{otherwise.} \end{cases}$$

Then each orbit of the torus action contains exactly one such x_σ and $O_\sigma := \mathbb{T}_N \cdot x_\sigma$ is isomorphic to $(\mathbb{R}^*)^{d-\dim \sigma}$.

2.2.2 Proposition: *A real toric variety is connected if and only if the rays of its fan generate $N/2N \cong N \otimes_{\mathbb{Z}} \mathbb{Z}/2$ as \mathbb{F}_2 -vector space.*

Proof: See [Uma], theorem 2.5. □

2.2.3 Proposition: (Uma) *Let X be a smooth and connected real toric variety. Then there is a presentation of the fundamental group of X with generators and relations as follows:*

Let $\{\rho_1, \dots, \rho_n\}$ be the set of generators of rays of $\Sigma(1)$, $\{\rho_1, \dots, \rho_d\}$ a subset, which forms a basis for $N \otimes_{\mathbb{Z}} \mathbb{Z}/2$ and let $\{\omega_1, \dots, \omega_d\}$ be the dual basis. Let $a_{j,i} := \langle \rho_j, \omega_i \rangle \pmod{\mathbb{Z}/2}$ for $1 \leq i \leq d, 1 \leq j \leq n$.

For $\underline{t} = (t_1, \dots, t_d) \in (\mathbb{Z}/2)^d$, let $b_i^j = t_i + a_{j,i}$ for $1 \leq i \leq d$ and $1 \leq j \leq n$ and let $c_i^{p,q} = t_i + a_{p,i} + a_{q,i}$ for $1 \leq i \leq d, 1 \leq p, q \leq n$. We shall denote the vector $(b_i^j)_{i=1, \dots, n}$ by \underline{b}^j and the vector $(c_i^{p,q})_{i=1, \dots, n}$ by $\underline{c}_i^{p,q}$.

Then the fundamental group $\pi_1(X)$ has a presentation with generators

$$\{y_{j,\underline{t}} : 1 \leq j \leq n \mid \underline{t} = (t_1, \dots, t_d) \in (\mathbb{Z}/2)^d\}$$

and relations

$$\bigcup_{\underline{t} \in (\mathbb{Z}/2)^d} \{y_{1,(0,\dots,0)}^{t_1} \cdot y_{2,(t_1,0,\dots,0)}^{t_2} \cdots y_{d,(t_1,\dots,t_{d-1},0)}^{t_d}\} \quad (\text{A})$$

$$\bigcup_{\underline{t} \in (\mathbb{Z}/2)^d} \{y_{j,\underline{t}} \cdot y_{j,\underline{b}^j} \mid 1 \leq j \leq n\} \quad (\text{B})$$

$$\bigcup_{\underline{t} \in (\mathbb{Z}/2)^d} \{y_{p,\underline{t}} \cdot y_{q,\underline{b}^p} \cdot y_{p,\underline{c}^{p,q}} \cdot y_{q,\underline{b}^q} \mid \langle \rho_p, \rho_q \rangle \in \Sigma(2)\} \quad (\text{C})$$

$\langle \rho_p, \rho_q \rangle$ designates the cone generated by ρ_p and ρ_q .

Proof: See [Uma], proposition 3.1. □

Remark: The fundamental group depends only on the 2-skeleton of the fan.

From now on, we will consider only quasi-projective toric varieties which are assigned to a rational polyhedron in M .

From the last section we already know how to assign a toric variety with a rational polyhedron (via its normal fan), but now we want to present an independent but equivalent construction. It yields important topological information on the variety, but there is a price to pay: It seems that it works for $\mathbb{K} = \mathbb{C}$ and its subfields only as it relies on topological properties such as the existence of a norm.

So, let $\Delta \subset M_{\mathbb{R}}$ be a (possibly unbounded) rational polyhedron. We further assume that its normal fan Σ_{Δ} is simplicial.

Let D be the divisor defining Δ . We define a new polyhedron

$$\tilde{\Delta} := \beta^{-1}([D]) \cap (\mathbb{R}_{\geq 0})^r = (\tilde{M}_{\mathbb{R}} + a) \cap (\mathbb{R}_{\geq 0})^r,$$

where β is the map in $(*)'$ in the last section, $a = (a_1, \dots, a_r)$ the coefficients of D and $\tilde{M}_{\mathbb{R}}$ the image of $M_{\mathbb{R}}$ in \mathbb{R}^r of the map α , also in $(*)'$. Δ and $\tilde{\Delta}$ are combinatorially equivalent.

We define

$$\mu_{\Sigma} : \mathbb{R}^r \xrightarrow{\mu} \mathbb{R}^r \xrightarrow{\beta} \text{Pic}_{\mathbb{R}}(X_{\Sigma})$$

by setting $\mu(x_1, \dots, x_r) := \frac{1}{2}(x_1^2, \dots, x_r^2)$. There is an action of $\mathbb{S}^r = \{\pm 1\}^r$ on \mathbb{R}^r by multiplication: $(x_1, \dots, x_r) \mapsto (\varepsilon_1 x_1, \dots, \varepsilon_r x_r), \varepsilon_i = \pm 1$. Taking $\text{Hom}(-, \mathbb{S})$ on the exact sequence $(*)$, we get the following exact sequence:

$$0 \longrightarrow \mathbb{S}^{r-d} \longrightarrow \mathbb{S}^r \longrightarrow \mathbb{S}^d \longrightarrow 0 \tag{**}$$

so there is also an action of \mathbb{S}^{r-d} on \mathbb{R}^r and an action of \mathbb{S}^d on $\mathbb{R}^r/\mathbb{S}^{r-d}$. Note that μ is invariant under these actions.

2.2.4 Proposition: X_Δ is a geometrical quotient for

$$\mu_\Sigma^{-1}([D])/\mathbb{S}^{r-d}$$

which preserves the torus action.

Proof: See [Cox1] for $\mathbb{K} = \mathbb{C}$. The construction clearly works analogously for $\mathbb{K} = \mathbb{R}$. \square

By the above construction we get an obvious homeomorphism from $X_\Sigma/\mathbb{S}^d = X_\Sigma^+$ to $\tilde{\Delta}$. Thereby an orbit closure $\overline{O_\sigma}$, where σ is generated by $\rho_{i_1}, \dots, \rho_{i_s}$, is mapped to the face of $\tilde{\Delta}$ defined by $x_{i_1} = \dots = x_{i_s} = 0$. In Δ , this is precisely the face orthogonal to σ . Such a homeomorphism can even be explicitly stated in the case of projective toric varieties in terms of a \mathbb{S}^d -invariant map $\mu : X_\Sigma \rightarrow \Delta$ (see [Ful] for more details). This map is called the *moment map*. The restriction of μ to $\xi \cdot X_\Sigma^+$, for $\xi \in \mathbb{S}^d$, will be designated by $\mu^{(\xi)}$.

So X_Σ is composed of copies $\xi \cdot \tilde{\Delta}$ of $\tilde{\Delta}$ (or to be precise: of equivalence classes of copies of $\tilde{\Delta}$), one for each $\xi \in \mathbb{S}^d$. If $\tilde{\Gamma} = \tilde{\Delta} \cap W$ is a face of $\tilde{\Delta}$ cut out by a linear subspace $W \subset \mathbb{R}^r$, then $\xi \cdot \tilde{\Gamma} = \xi' \cdot \tilde{\Gamma}$ if and only if ξ and ξ' coincide on $(W \cap \mathbb{Z}^r)/\mathbb{S}^{r-d}$. Taking this result over to Δ instead of $\tilde{\Delta}$ we get the following topological construction:

2.2.5 Proposition: Let Σ be a full-dimensional simplicial fan in N , being the normal fan to some nonempty rational polyhedron $\Delta \subset M$. Let X be the polyhedral complex obtained by taking one copy $\Delta^{(\xi)}$ of Δ for each $\xi \in \mathbb{S}^d$ and glueing the faces $\Gamma^{(\xi)}$ and $\Gamma^{(\xi')}$ if and only if $\xi \cdot \xi'$ is constant on $\text{Aff}(\Gamma) \cap M$, where $\text{Aff}(\Gamma)$ is the affine subspace in $M_{\mathbb{R}}$ generated by Γ . Then X and X_Σ are p.l. homeomorphic.

Moreover, the homeomorphism can be chosen in such a way that for each $\sigma \in \Sigma$ the orbit O_σ is mapped to the interior of the faces $\Gamma^{(\xi)}$ where Γ is the face of Δ orthogonal to σ .

2.2.6 Corollary: If for two fans Σ, Σ' as above there exists an inclusion-preserving bijection $f : \Sigma \rightarrow \Sigma'$, such that the images of $\sigma \cap \mathbb{Z}^d$ and $f(\sigma) \cap \mathbb{Z}^d$ in $(\mathbb{Z}/2\mathbb{Z})^d$ are equal for all $\sigma \in \Sigma$, then the corresponding real toric varieties X_Σ and $X_{\Sigma'}$ are p.l. homeomorphic.

Proof: The corresponding polyhedra Δ and Δ' are combinatorially equivalent (since their combinatorial structure is dual to the fans). For any face Γ of Δ the above described glueing condition can be reformulated as $\xi \cdot \xi' \in \text{Hom}(\text{Lin}(\Gamma^\perp), \{\pm 1\}) = \text{Hom}(\text{Lin}(\sigma_\Gamma), \{\pm 1\}) = \text{Hom}(\text{Lin}_2(\sigma_\Gamma), \{\pm 1\})$ (see section 1.2). The assertion now follows as $\text{Lin}_2(\sigma_\Gamma) = \text{Lin}_2(\sigma_{\Gamma'})$, hence the glueing rules on Δ and Δ' coincide. \square

2.2.7 Proposition: *Let $X = X_\Delta$ be a smooth real toric variety. Then X and also the compactification \overline{X} , defined as in section 1.1, are PL-manifolds.*

Proof: With proposition 1.1.30 it suffices to show that X is a PL-manifold.

Let $x \in X_\Delta$ be a point. Without loss of generality we can assume that x is a vertex of Δ , so it corresponds to a full-dimensional cone σ_x (and $x = O_{\sigma_x}$). Let $U \subset X$ be an open neighbourhood of x that contains no other vertex of Δ . Then U is homeomorphic and also p.l. homeomorphic to the affine real toric variety X_{σ_x} . As X_Δ is smooth, σ_x is generated by a \mathbb{Z} -basis of \mathbb{Z}^d , so U is p.l. homeomorphic to \mathbb{R}^d . \square

Example: Let $N = \mathbb{Z}^2$ and Σ the fan generated by $\rho_1 = e_1, \rho_2 = e_1 + e_2, \rho_3 = e_2$.

It is well known that X_Σ is the blow-up of the affine plane in the origin. The exact sequence (*) becomes

$$0 \longrightarrow \mathbb{Z}^2 \xrightarrow{\alpha} \mathbb{Z}^3 \xrightarrow{\beta} \mathbb{Z} \longrightarrow 0$$

and the mappings are given by $\alpha : (u_1, u_2) \mapsto (u_1, u_1 + u_2, u_2)$ and $\beta : (x_1, x_2, x_3) \mapsto x_1 - x_2 + x_3$.

Let the function ψ be given by $\psi(\rho_1) = 0, \psi(\rho_2) = 1, \psi(\rho_3) = 3$, corresponding to the divisor $D = (0, 1, 3)$ which defines the divisor class $[D] = 2$. This gives rise to the polyhedron

$$\Delta := \{m \in M_{\mathbb{R}} \mid m_1 \geq 0, m_1 + m_2 \geq -1, m_2 \geq -3\}$$

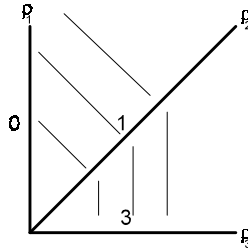

Figure 2.6: The fan Σ

as well as to the polyhedron

$$\tilde{\Delta} := \{x \in \mathbb{R}^3 \mid x_1 - x_2 + x_3 = 2 \text{ and } x_1, x_2, x_3 \geq 0\}.$$

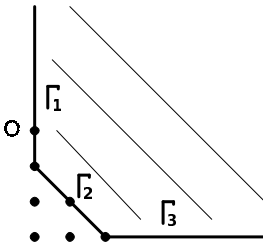

Figure 2.7: The polyhedron Δ

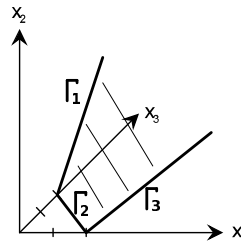

Figure 2.8: The polyhedron $\tilde{\Delta}$

We have

$$\mu_{\Sigma}^{-1}([D]) = \{x_1^2 - x_2^2 + x_3^2 = 4\}$$

and the action of the nontrivial element of $\mathbb{S} = \text{Hom}(\mathbb{Z}, \mathbb{S})$ is given by $(x_1, x_2, x_3) \mapsto (-x_1, -x_2, -x_3)$. Thus we obtain a space \tilde{X} homeomorphic to X by identifying points of opposite sign of the above hyperboloid or, equivalently, by considering only the upper half of it (i.e. $x_2 \geq 0$), identifying opposite points of its boundary circle.

This boundary circle corresponds to the exceptional curve of X , which is the closure of O_{ρ_2} and in the same way every other orbit

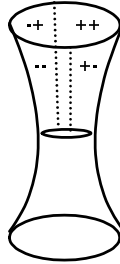

Figure 2.9: The hyperboloid $\mu_{\Sigma}^{-1}([D])$

closure $\overline{O_{\sigma}}$ can be recognized as $\tilde{X} \cap \{x_{i_1} = \dots = x_{i_k} = 0\}$, where $\rho_{i_1}, \dots, \rho_{i_k}$ are the 1-dimensional cones contained in σ .

Looking only at the upper half, it is clear that \tilde{X} consists of four copies of Δ glued together. We label them according to the signs of the coordinates x_1 and x_3 and interpret these labels as elements of $\mathbb{S}^2 = \text{Hom}(M, \mathbb{S})$. So we get $\Delta^{(++)}, \Delta^{(+-)}, \Delta^{(-+)}, \Delta^{(--)}$ and the action of \mathbb{S}^2 gives $\xi \cdot \Delta^{(\xi')} = \Delta^{(\xi\xi')}$. Designating by $\tilde{\Gamma}_i := \tilde{\Delta} \cap \{x_i = 0\}, i = 1, \dots, 3$ the facets of $\tilde{\Delta}$, it is easy to verify that

$$\begin{aligned} \tilde{\Gamma}_1^{(++)} &= \tilde{\Gamma}_1^{(-+)}, \tilde{\Gamma}_1^{(+-)} = \tilde{\Gamma}_1^{(--)}, \\ \tilde{\Gamma}_3^{(++)} &= \tilde{\Gamma}_3^{(+-)}, \tilde{\Gamma}_3^{(-+)} = \tilde{\Gamma}_3^{(--)}, \\ \tilde{\Gamma}_2^{(++)} &= \tilde{\Gamma}_2^{(--)}, \tilde{\Gamma}_2^{(+-)} = \tilde{\Gamma}_2^{(-+)}, \end{aligned}$$

where the last line comes from the identification under the action of \mathbb{S} on the hyperboloid. The 0-dimensional faces are analogously identified.

Carrying on the identifications to Δ instead of $\tilde{\Delta}$, we get the same result by taking a copy $\Delta^{(\xi)}$ of Δ for each $\xi \in \mathbb{S}^2$ and glueing the faces $\Gamma^{(\xi)}$ with $\Gamma^{(\xi')}$ each time ξ and ξ' coincide on the lattice points of the (now affine) subspace generated by Γ .

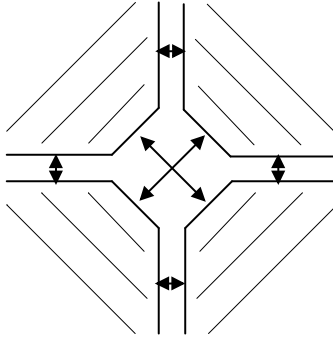
Figure 2.10: Glueing of the copies of Δ

2.3 Virtual Betti Numbers

Classically, Betti numbers of a topological space or an algebraic variety are defined as dimensions of certain cohomology groups. There are many ways to introduce cohomology for various classes of objects (we will not cover this topic here, see instead [Hart] for a sheaf theoretic definition or [DFN] for a topological definition), but in our setting and with a little care on the question of compactness they fortunately all coincide.

2.3.1 Definition: Let $X = X_{\mathbb{R}}$ be a real algebraic variety, A an abelian group and i a nonnegative integer. We set $H_c^i(X_{\mathbb{R}}, A)$ and $H_c^i(X_{\mathbb{C}}, A)$ to be the singular cohomology groups with compact support of the topological spaces $X_{\mathbb{R}}$ and $X_{\mathbb{C}}$ respectively (where $X_{\mathbb{C}}$ is the complexification of X). The (classical) i -th Betti number of X is defined as

$$b^i(X) := \dim H_c^i(X_{\mathbb{R}}, \mathbb{Z}/2\mathbb{Z}).$$

The polynomial

$$P_X(t) := \sum_{i \geq 0} b^i(X) t^i$$

is called the *Poincaré polynomial* of X and

$$\chi(X) := P_X(-1) = \sum_{i \geq 0} (-1)^i b^i(X)$$

the *Euler characteristic* of X .

In the above definitions it would be equivalent to take sheaf cohomology or Borel-Moore cohomology (see [MCP]). Note however that it is necessary to take compact supports to get the “correct” Euler characteristic (see prop. 2.3.8).

On compact nonsingular real varieties the Betti numbers have many nice properties, e.g. they are additive for the disjoint union of two varieties and the Poincaré polynomial is multiplicative for a product of varieties.

In [MCP] McCrory and Parusiński suggest a definition of invariants of real algebraic varieties, which coincide with the usual Betti numbers on compact nonsingular varieties, and extend the aforementioned properties to all other real varieties. They cannot longer be seen as ranks of certain groups or modules as they may become negative, so McCrory and Parusiński call them “virtual Betti numbers”. The precise definition is as follows:

Let $K_0(\mathcal{V}_{\mathbb{R}})$ denote the Grothendieck ring of real algebraic varieties. It is generated as abelian group by symbols $[X]$, where X is a real algebraic variety, and the following relations:

- (1) $[X] = [Y]$ if X and Y are isomorphic,
- (2) $[X] = [X \setminus Y] + [Y]$ if Y is a closed subvariety of X .

The product of $K_0(\mathcal{V}_{\mathbb{R}})$ is given as the product of varieties:

- (3) $[X] \cdot [Y] = [X \times Y]$.

2.3.2 Proposition: *There exists a unique ring homomorphism*

$$\beta : K_0(\mathcal{V}_{\mathbb{R}}) \rightarrow \mathbb{Z}[t]$$

such that $\beta([X])(t) = \sum_{i \geq 0} b^i(X)t^i$.

Proof: See [MCP]. □

2.3.3 Corollary: For each $i \geq 0$ there exists a unique group homomorphism

$$\beta^i : K_0(\mathcal{V}_{\mathbb{R}}) \rightarrow \mathbb{Z}$$

such that $\beta^i(X) = b^i(X)$ for X compact and smooth.

Proof: Setting $\beta^i([X])$ as the coefficient of t^i in $\beta([X], t)$ fulfills the required condition. \square

Remark: As on compact nonsingular varieties $\beta([X], t)$ equals the Poincaré polynomial, which is known to be multiplicative, the assertions of the proposition and the corollary are in fact equivalent.

2.3.4 Definition: The numbers $\beta^i(X) := \beta^i([X])$ are called *virtual Betti numbers* of X and $\beta(X; t) := \beta([X])(t)$ the *virtual Poincaré polynomial* of X .

2.3.5 Proposition: The virtual and non-virtual Euler characteristics coincide for all real algebraic varieties X , that is $\chi(X) = \sum_{i \geq 0} (-1)^i \beta^i(X)$.

Proof: See [MCP]. \square

2.3.6 Proposition: Let $d \geq 0$ be an integer. Then

$$\beta((\mathbb{R}^*)^d; t) = (t - 1)^d$$

and so

$$\beta^i((\mathbb{R}^*)^d) = (-1)^{d-i} \binom{d}{i}$$

for $i = 0, \dots, d$.

Proof: For $d = 0$ the statement is obviously true.

For $d = 1$ we may view \mathbb{R}^* as $\mathbb{RP}^1 \setminus \{0, \infty\}$. Hence by the additivity of the virtual Betti numbers

$$\beta^i(\mathbb{R}^*) = \beta^i(\mathbb{RP}^1) - 2\beta^i(\text{pt.}) = b^i(\mathbb{RP}^1) - 2b^i(\text{pt.}).$$

So,

$$\beta^0(\mathbb{R}^*) = 1 - 2 = -1 = (-1)^1 \binom{1}{0}$$

and

$$\beta^1(\mathbb{R}^*) = 1 - 0 = 1 = (-1)^{1+1} \binom{1}{1}.$$

For $d \geq 2$, by multiplicity of the virtual Poincaré polynomial,

$$\beta((\mathbb{R}^*)^d; t) = (\beta(\mathbb{R}^*; t))^d = (-1 + t)^d = \sum_{i=0}^d (-1)^{d+i} \binom{d}{i} t^i,$$

hence $\beta^i((\mathbb{R}^*)^d) = (-1)^{d+i} \binom{d}{i}$. □

2.3.7 Corollary: *Let X be a d -dimensional toric variety assigned to a fan Σ . Then for $i = 0, \dots, d$*

$$\beta(X; t) = \sum_{k=0}^d (t-1)^{d-k} \#\Sigma(k),$$

so

$$\beta^i(X) = \sum_{k=0}^{d-i} (-1)^{d-i-k} \binom{d-k}{i} \#\Sigma(k).$$

Proof: X is a disjoint union of torus orbits:

$$X = \bigcup_{\sigma \in \Sigma} O_\sigma,$$

with $O_\sigma \cong (\mathbb{R}^*)^{d-\dim(\sigma)}$. So by the additivity of the virtual Poincaré polynomial

$$\begin{aligned}\beta(X; t) &= \sum_{\sigma \in \Sigma} \beta(O_\sigma; t) = \sum_{k=0}^d \sum_{\sigma \in \Sigma(k)} \beta((\mathbb{R}^*)^{d-k}; t) \\ &= \sum_{k=0}^d (t-1)^{d-k} \#\Sigma(k).\end{aligned}$$

Taking the coefficient of t^i as $\beta^i(X)$ yields the statement. \square

2.3.8 Proposition: *Let X be a toric variety defined by a rational polytope Δ . Then the Euler characteristic of X defined as in this section is equal to the Euler characteristic defined as in section 1.1, where X is viewed as polytopal complex.*

Proof: As in both definitions the Euler characteristic is additive, it is enough to show the assertion for the affine space. So let $X = (\mathbb{R}^*)^d$ for some $d \geq 0$. As $H_c^i(\mathbb{R}^d, \mathbb{Z}/2\mathbb{Z}) = 0$ for $i = 0, \dots, d-1$ and $H_c^d(\mathbb{R}^d, \mathbb{Z}/2\mathbb{Z}) \cong \mathbb{Z}/2\mathbb{Z}$ we have $\chi(X) = (-1)^d$ (using the above definition).

On the other hand we can view X as toric variety to the polytope $\Delta = (\mathbb{R}_{\geq 0})^d$. Δ has exactly $\binom{d}{k}$ k -dimensional faces. Each k -dimensional face has exactly 2^k copies in X . So

$$\chi(X) = \sum_{k=0}^d (-1)^k 2^k \binom{d}{k} = (-1)^d,$$

which coincides with the above result. \square

III Real Local Toric Calabi-Yau Varieties

3.1 Definition

Let d be a positive integer, Θ a lattice polytope in \mathbb{R}^{d-1} and \mathcal{T} a unimodular coherent lattice triangulation of Θ . For each simplex $\sigma \in \mathcal{T}$ let $\text{cone}(\sigma)$ be the cone generated by $\sigma \times \{1\} \subset \mathbb{R}^d$. Let Σ be the d -dimensional fan consisting of all such cones. We call Σ the *fan over \mathcal{T}* .

The d -dimensional real toric variety X_Σ associated with this fan is called a *real local toric Calabi-Yau variety* (*real local toric K3 surface*, if $d = 2$).

If \mathcal{T} is an arbitrary $(d - 1)$ -dimensional complex of lattice simplices, then the analogously constructed real toric variety will be called *generalized real local toric Calabi-Yau variety*.

Remark: As we will explain in the next chapter, real local toric Calabi-Yau varieties occur as a resolution of singularities in the construction of compact Calabi-Yau varieties. For generalized real local Calabi-Yau varieties this is not true anymore. They will instead occur mainly as intermediate steps in induction proofs of this chapter. But since many results on real local Calabi-Yau varieties stated in terms of the combinatoric description of the triangulation can easily be extended to greater generality, we will do so, where it seems

appropriate to us.

Example: We fix a natural number $n \geq 1$. $\Theta := [0, n]$ is a one-dimensional lattice polytope, which has a unique maximal lattice triangulation (which is the subdivision into intervals of length one). The fan over it is seen in figure 3.11.

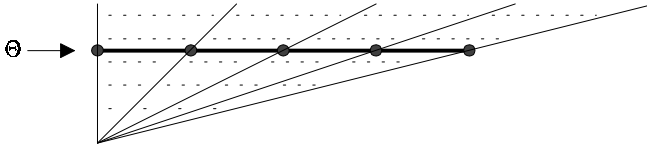

Figure 3.11: The fan Σ for $n = 4$

3.2 General Results

In this section we calculate the Euler characteristic and virtual Betti numbers of generalized real local toric Calabi-Yau varieties. If the varieties are non-generalized, we construct a natural compactification and determine the number of boundary components. We conclude with the conjectures that in all dimensions the classical Betti numbers coincide with the virtual ones and that they are independent of the triangulation of the defining lattice polytope.

3.2.1 Proposition: *A generalized real local toric Calabi-Yau variety is smooth if and only if it is defined by a unimodular simplicial lattice complex. In particular (non-generalized) real local toric Calabi-Yau varieties are smooth.*

Proof: This follows immediately from the definitions. □

3.2.2 Proposition: *A smooth generalized real local toric Calabi-Yau variety has trivial canonical class.*

Proof: Let X_Σ be a generalized real local toric Calabi-Yau variety, associated with the fan Σ . It was stated in proposition 2.1.9 that $K = -\sum_{\rho \in \Sigma(1)} D_\rho$ is a canonical divisor (where the $D_\rho = \overline{O}_\rho$ denote the primitive invariant Weil-divisors). In this case, all generators of the rays (which we also denote with ρ) lie on the affine hyperplane $\{u = 1\}$, where $u \in (\mathbb{R}^d)^\vee$ is the d -th co-ordinate form. We can also view u as a rational function on X_Σ , giving rise to a principal divisor $D = \sum_{\rho \in \Sigma(1)} \langle u, \rho \rangle D_\rho$. Obviously $D = -K$, so K is principal. \square

3.2.3 Proposition: *Any smooth real algebraic variety with trivial canonical class is an orientable smooth manifold.*

Proof: Let X be a smooth real algebraic variety. It is well-known (and follows from the implicit function theorem) that X is also a smooth real manifold. Therefore it suffices to show that X is orientable.

The fact that the canonical class of X is trivial is equivalent to the existence of a rational n -form $\omega \in \Omega^n(X)$ without zeros and poles. For each $x \in X$ we define an orientation class depending smoothly on x in the following way:

Let x_1, \dots, x_d be local coordinates in an open subset $U \subset X$, in which ω can be written as

$$\omega(x_1, \dots, x_d) = f(x_1, \dots, x_d) dx_1 \wedge \dots \wedge dx_d$$

for a real-valued rational function f (X can be covered by such sets). By construction, f has neither zeros nor poles.

For each point in U with coordinates (x_1, \dots, x_d) this determines an ordered base

$$B(x_1, \dots, x_d) := f(x_1, \dots, x_d) \left(\frac{\partial}{\partial x_1}, \dots, \frac{\partial}{\partial x_d} \right)$$

of the tangent space of U at this point and so determines also an orientation class. It is clear that this assignment is continuous. We

show that it is independent of the choice of local coordinates and so can be extended to the whole manifold X :

If y_1, \dots, y_d are other local coordinates, then

$$\left(\frac{\partial}{\partial x_1}, \dots, \frac{\partial}{\partial x_d}\right) = \left(\frac{\partial}{\partial y_1}, \dots, \frac{\partial}{\partial y_d}\right)A$$

for a nonsingular $d \times d$ -matrix $A = (a_{ij})_{i,j}$, with $a_{ij} = \frac{\partial y_i}{\partial x_j}$.

In the new coordinates we have

$$\omega(y_1, \dots, y_d) = \tilde{f}(y_1, \dots, y_d)dy_1 \wedge \dots \wedge dy_d$$

with

$$\tilde{f}(y_1, \dots, y_d) = \det(A)f(x_1, \dots, x_d)$$

with the same matrix A as above (the x_i are hereby considered as functions of y_1, \dots, y_d). So,

$$f(x_1, \dots, x_d)\left(\frac{\partial}{\partial x_1}, \dots, \frac{\partial}{\partial x_d}\right) = \tilde{f}(y_1, \dots, y_d)\left(\frac{\partial}{\partial y_1}, \dots, \frac{\partial}{\partial y_d}\right)\frac{A}{\det(A)}$$

and as $\det\left(\frac{A}{\det(A)}\right) = 1$, we have shown that the choice of orientation class does not depend on the choice of local coordinates, which concludes the proof. \square

3.2.4 Corollary: *Let X be a smooth generalized real local Calabi-Yau variety. Then X is a connected orientable real manifold.*

Proof: Let Σ be the fan defining X . As it contains a fulldimensional cone, proposition 2.2.2 yields that X is connected. Together with the two previous results the assertion now follows. \square

3.2.5 Proposition: *Let d be a positive integer and \mathcal{T} a $(d-1)$ -dimensional simplicial lattice complex in \mathbb{R}^d . Let X be the associated generalized real local Calabi-Yau variety. Then its Euler characteristic amounts to*

$$\chi(X) = (-2)^d + \sum_{k=0}^{d-1} (-2)^{d-1-k} \#\mathcal{T}(k).$$

If \mathcal{T} is a unimodular triangulation of a lattice polytope Θ , then the Euler characteristic can be expressed as

$$\chi(X) = Q(\Theta; -1),$$

where $Q(\Theta; t)$ is the polynomial defined in section 1.2. In particular, it is independent of the actual choice of triangulation.

For low dimensions and smooth varieties the formula for the Euler characteristic can be simplified in the following way:

- a) For $d = 2$ and $\Theta = [0, n]$: $\chi(X) = 2 - n$.
- b) For $d = 3$: $\chi(X) = l(\partial\Theta) - 4$, where $l(\partial\Theta)$ designates the number of lattice points in $\partial\Theta$.
- c) For $d = 4$: $\chi(X) = \frac{1}{2}\text{vol}(\partial\Theta) + \kappa(\Theta) - 5l(\Theta) + 13$, where $\kappa(\Theta)$ designates the number of edges in a unimodular triangulation of Θ .

Proof: Let Σ be the fan over \mathcal{T} (so $X = X_\Sigma$). We consider the decomposition of X into orbits under the action of the torus $(\mathbb{R}^*)^d$:

$$X = \dot{\bigcup}_{\sigma \in \Sigma} O_\sigma.$$

If σ is k -dimensional, then O_σ is isomorphic to the $(d-k)$ -dimensional torus and consists of 2^{d-k} connected, contractible components. So

$$\begin{aligned} \chi(X) &= \sum_{k=0}^d (-1)^{d-k} \sum_{\sigma \in \Sigma(k)} 2^{d-k} \\ &= (-2)^d \#\Sigma(0) + \sum_{k=1}^d (-2)^{d-k} \#\Sigma(k) \end{aligned}$$

which is equal to the claimed formula, as $\Sigma(0) = \{0\}$ and $\#\Sigma(k+1) = \#\mathcal{T}(k)$ for all $k \geq 0$ by the construction of the fan.

Now assume that \mathcal{T} is a unimodular triangulation of a lattice polytope Θ . By proposition 1.2.13 the Q -polynomial of Θ can be written as

$$Q(\Theta; t) = (t - 1)^d + \sum_{k=0}^{d-1} \#\mathcal{T}(k) (t - 1)^{d-1-k}.$$

It is easy to verify that for $t = -1$ this is equal to the above formula for the Euler characteristic of X . As the definition of the Q -polynomial does not involve any triangulation, the Euler characteristic is independent of it.

Now we consider the special cases. For commodity, we set $f_k := \#\mathcal{T}(k)$ for $k = 0, \dots, d - 1$.

If $d = 2$ then the above formula yields

$$\begin{aligned} \chi(X) &= 4 - 2f_0 + f_1 = 2 - f_1 \\ &= 2 - n \end{aligned}$$

as $f_0 = f_1 + 1$ and $f_1 = n$.

Now let $d = 3$: The above formula yields

$$\begin{aligned} \chi(X) &= -8 + 4f_0 - 2f_1 + f_2 \\ &= -6 + 2f_0 - f_2, \end{aligned}$$

where we have used the Euler formula $f_0 - f_1 + f_2 = \chi(\Theta) = 1$ to make the f_1 -term disappear. We can further simplify this result using the formula of corollary 1.2.11 for triangulations of two-dimensional convex polytopes

$$\text{vol}(\Theta) = l(\Theta) + l^*(\Theta) - 2,$$

when we have here $f_2 = \text{vol}(\Theta)$ and $f_0 = l(\Theta)$:

$$\begin{aligned} \chi(X) &= l(\Theta) - l^*(\Theta) - 4 \\ &= l(\partial\Theta) - 4. \end{aligned}$$

For $d = 4$ the same type of calculation leads to

$$\chi(\Theta) = -f_3 + 2f_1 - 6f_0 + 14.$$

This result can be slightly simplified to the assertion by using the formula of prop. 1.2.10 for triangulations of 3-dimensional polytopes:

$$2f_3 = -f_2^\partial + 2f_1 - 2f_0 + 2.$$

□

3.2.6 Proposition: *Let \mathcal{T} be a $(d-1)$ -dimensional simplicial lattice complex and X the d -dimensional generalized real local Calabi-Yau variety defined by it. Then the virtual Poincaré polynomial of X can be calculated as*

$$\beta(X; t) = (t-1)^d + \sum_{k=0}^{d-1} (t-1)^{d-1-k} \#\mathcal{T}(k).$$

The individual Betti numbers are

$$\beta^i(X) = (-1)^{d-i} \binom{d}{i} + \sum_{k=0}^{d-1-i} (-1)^{d-1-i-k} \binom{d-1-k}{i} \#\mathcal{T}(k)$$

for $i = 0, \dots, d$. In particular,

$$\begin{aligned} \beta^0(X) &= 0, \\ \beta^d(X) &= 1. \end{aligned}$$

If \mathcal{T} is a unimodular triangulation of a lattice polytope Θ , then the virtual Poincaré polynomial of X is equal to the Q -polynomial of Θ , that is

$$\beta(X; t) = \sum_{i=0}^d \beta^i(X) t^i = Q(\Theta; t).$$

In particular, the virtual Betti numbers are independent of the actual choice of triangulation.

Proof: The formula for the virtual Poincaré polynomial is a direct consequence of the orbit decomposition of X and the additivity of the virtual Poincaré polynomial (see also proposition 2.3.7). Its coefficients can easily be calculated to give the virtual Betti numbers as stated above.

By putting $i = d$ we get immediately

$$\beta^d(X) = (-1)^{2d} \binom{d}{d} = 1.$$

For $i = 0$ we get

$$\begin{aligned} (-1)^d \beta^0(X) &= \binom{d}{0} - \sum_{k=0}^{d-1} (-1)^k \binom{d-1-k}{0} \mathcal{T}(k) \\ &= 1 - \chi(\Theta) \\ &= 0. \end{aligned}$$

If \mathcal{T} is a unimodular triangulation of Θ , then it is easy to verify that the virtual Betti polynomial coincides with the Q -polynomial of Θ as described in proposition 1.2.13. \square

3.2.7 Theorem: Let $\Theta \subset \mathbb{R}^{d-1}$ be a $(d-1)$ -dimensional lattice polytope and \mathcal{T} a unimodular coherent triangulation of Θ . Let X be the real local toric Calabi-Yau variety defined by these.

Then X is a quasi-projective algebraic variety. Let \overline{X} be the compactification of X , constructed as d -dimensional polytopal complex as described in section 1.1, so that X is p.l. homeomorphic to $\overline{X} \setminus \partial \overline{X}$.

Then \overline{X} is a d -dimensional PL-manifold with boundary. $\partial \overline{X}$ is a $(d-1)$ -dimensional closed PL-manifold. It has $2^{d-1-\dim_2 \partial \Theta}$ components, where $\dim_2 \partial \Theta = \dim_2 \partial \mathcal{T}$ is the dimension of the affine \mathbb{F}_2 -subvector space of $(\mathbb{Z}/2)^{d-1}$ generated by the lattice points of $\partial \Theta$.

Proof: Any piecewise affine-linear map on \mathcal{T} gives rise to a piecewise linear map on the fan Σ over \mathcal{T} by linear continuation. So according

to proposition 2.1.13, Σ is the normal fan of an unbounded polytope Δ and X is a quasi-projective algebraic variety. Topologically, by proposition 2.2.4, X is the realization of a polytopal complex obtained by glueing 2^d copies of Δ along their faces and \overline{X} is the result of the induced glueing of copies of $\overline{\Delta}$, where $\overline{\Delta}$ is the closure of Δ . Let Γ be the closing facet of Δ (recall that Δ is combinatorially equivalent to $\overline{\Delta} \setminus \Gamma$), then $\partial\overline{X}$ is the result of the induced glueing of the copies of Γ . As Γ is bounded, $\partial\overline{X}$ is compact.

We further know that the facets of Γ are in one-to-one correspondence to the vertices of the triangulation of $\partial\Theta$. So, if F is the facet corresponding to $v \in \partial\Theta \cap \mathbb{Z}^d$ and $\{F^{(\xi)} \mid \xi \in \text{Hom}(\mathbb{Z}^d, \{\pm 1\})\}$ are the copies of it, then $F^{(\xi)}$ is identified with $F^{(\xi')}$ if and only if $\xi = \hat{v} \cdot \xi'$ (where $\hat{v} \in \text{Hom}(\mathbb{Z}^d, \{\pm 1\})$ is the homomorphism defined by v respectively $\bar{v} \in (\mathbb{Z}/2)^d$, see section 1.2 for the definition). So every copy of a facet has a “glueing partner” and $\partial\overline{X}$ has no boundary.

We further deduce that $\Gamma^{(\xi)}$ and $\Gamma^{(\xi')}$ are in the same component of $\partial\overline{X}$ if and only if $\xi = \hat{g}\xi'$ for some $g \in G := \langle \bar{v} \mid F \text{ is a facet of } \Gamma \rangle$ (where G is a subgroup of $(\mathbb{Z}/2)^d$). So the components of $\partial\overline{X}$ are in 1-1-correspondence with elements of $(\mathbb{Z}/2)^d/G$. As all these groups are naturally \mathbb{F}_2 -vector spaces, this number is equivalently described by $2^{\dim_{\mathbb{F}_2}(\mathbb{F}_2)^d/G}$.

Let $\partial\Theta \cap \mathbb{Z}^d = \{v_0, \dots, v_s\}$. Then

$$\begin{aligned} (\mathbb{F}_2)^d/G &\cong \left((\mathbb{F}_2)^d/\bar{v}_0\mathbb{F}_2 \right) / \left(G/\bar{v}_0G \right) \\ &\cong (\mathbb{F}_2)^{d-1}/H, \end{aligned}$$

where $H = \langle \bar{v}_1 - \bar{v}_0, \dots, \bar{v}_s - \bar{v}_0 \rangle_{\mathbb{F}_2}$, which is a subvectorspace of $(\mathbb{F}_2)^{d-1}$. As $\dim H = \dim_2 \partial\Theta$, the assertion follows.

By proposition 3.2.1 X is smooth and thus by proposition 2.2.7 we know that X , \overline{X} and $\partial\overline{X}$ are PL-manifolds. \square

3.2.8 Proposition: *If $d = \dim X$ is odd, then*

$$\chi(\partial\overline{X}) = -2\chi(X)$$

(whereas if d is even, then $\chi(\partial\overline{X}) = 0$).

Proof: We use the fact that because of Poincaré-duality the Euler characteristic of an odd-dimensional closed smooth manifold is zero. If d is even, then $\partial\bar{X}$ is odd-dimensional, so its Euler characteristic is zero. If d is odd, then we can glue two copies of \bar{X} along the boundary. The resulting manifold is closed and consists of two copies of X and one of $\partial\bar{X}$. As the Euler characteristic is additive we get

$$0 = 2\chi(X) + \chi(\partial\bar{X}),$$

hence the desired result. \square

3.2.9 Proposition: *The Euler characteristic of the boundary can also be calculated as*

$$\chi(\partial\bar{X}) = 2 \left[(-2)^{d-1} + \sum_{k=0}^{d-2} (-2)^{d-2-k} \#\partial\mathcal{T}(k) \right],$$

where $\partial\mathcal{T}$ is the induced triangulation of $\partial\Theta$.

Proof: $\partial\bar{X}$ is by construction the realization of a polytopal complex K , which consists of 2^{k+1} copies of each k -dimensional face of a polytope Γ (for $k = 0, \dots, d-1$). These faces are in one-to-one correspondence to the $(d-2-k)$ -dimensional elements of \mathcal{T} , except for the 2^d copies of Γ itself. So,

$$\begin{aligned} \chi(\partial\bar{X}) &= \chi(K) \\ &= 2^d (-1)^{\dim \Gamma} + \sum_{F \in K} 2^{k+1} (-1)^{\dim F} \\ &= 2^d (-1)^{d-1} + \sum_{\sigma \in \mathcal{T}} 2^{d-1-\dim \sigma} (-1)^{d-2-\dim \sigma} \\ &= 2 \left[(-2)^{d-1} + \sum_{k=0}^{d-2} (-2)^{d-2-k} \#\partial\mathcal{T}(k) \right]. \end{aligned}$$

\square

Remark: Proposition 3.2.5 on the one hand and propositions 3.2.8 and 3.2.9 on the other hand yield two different possibilities to calculate the Euler characteristic of an odd-dimensional real local toric Calabi-Yau variety. This is not only useful for finding the simplest representation of the Euler characteristic for a given degree, but also makes it possible to deduce some relations between the numbers of simplices in a unimodular coherent triangulation of a lattice polytope. For example, the proof of prop. 3.2.5b makes use of the formula $(*) \operatorname{vol}(\Theta) = l(\Theta) + l^*(\Theta) - 2$ for 2-dimensional lattice polytopes, but we could also have derived 3.2.5b from 3.2.5a by means of propositions 3.2.8 and 3.2.9 and thus providing a proof for $(*)$.

In the same way, for d odd the Euler characteristic of a d -dimensional real local toric Calabi-Yau variety can always be derived from the formula of the $(d - 1)$ -dimensional varieties. We will show how this works out for $d = 5$ and derive a non-obvious relation for the combinatorics of a 4-dimensional lattice polytope.

It is convenient to replace the Euler characteristic by an invariant which makes not only sense for triangulations of lattice polytopes but also for more general simplicial complexes. We choose the definition in such a way that the invariant has the property of being additive (in an appropriate sense).

3.2.10 Definition: Let \mathcal{T} be any m -dimensional simplicial complex. Then we define

$$\gamma(\mathcal{T}) := \sum_{\sigma \in \mathcal{T}} (-2)^{m - \dim(\sigma)} = \sum_{k=0}^m (-2)^{m-k} \#\mathcal{T}(k).$$

3.2.11 Proposition: Let $\mathcal{T}, \mathcal{T}'$ be two m -dimensional simplicial complexes, such that $\mathcal{T} \cap \mathcal{T}'$ is a l -dimensional simplicial complex (with $l \leq m$). Then

$$\gamma(\mathcal{T} \cup \mathcal{T}') = \gamma(\mathcal{T}) + \gamma(\mathcal{T}') - (-2)^{m-l} \gamma(\mathcal{T} \cap \mathcal{T}').$$

Proof: This can be verified in a straightforward way. □

3.2.12 Proposition: Let Θ be a $(d - 1)$ -dimensional lattice polytope, \mathcal{T} a unimodular coherent triangulation of it, X the associated real local toric Calabi-Yau variety and \overline{X} the closure of it. Then

$$\begin{aligned}\chi(X) &= (-2)^d + \gamma(\mathcal{T}), \\ \chi(\partial\overline{X}) &= -(-2)^d + 2\gamma(\partial\mathcal{T}).\end{aligned}$$

Furthermore, for d odd

$$\gamma(\mathcal{T}) = (-2)^{d-1} - \gamma(\partial\mathcal{T}),$$

whereas for d even

$$\gamma(\partial\mathcal{T}) = -(-2)^{d-1}.$$

Proof: The formulas are just reformulations of propositions 3.2.5, 3.2.9 and 3.2.8 in terms of the γ -invariant. \square

3.2.13 Proposition: Let \mathcal{T} be a unimodular coherent triangulation of a $(m + 1)$ -dimensional lattice polytope for some nonnegative integer m (so $|\mathcal{T}| \cong S^m$). If m is even, then

$$\gamma(\mathcal{T}) = -(-2)^{m+1}.$$

If m is odd and $\mathcal{U}_1, \mathcal{U}_2$ are subcomplexes of \mathcal{T} such that

- $\mathcal{T} = \mathcal{U}_1 \cup \mathcal{U}_2$,
- $|\mathcal{U}_1|, |\mathcal{U}_2| \cong B^m$,
- $|\mathcal{U}_1 \cap \mathcal{U}_2| \cong S^{m-1}$,

then

$$\gamma(\mathcal{T}) = \gamma(\mathcal{U}_1) + \gamma(\mathcal{U}_2) + (-2)^{m+1}.$$

Proof: If m is even, then $|\mathcal{T}|$ is the boundary of an odd-dimensional lattice polytope. By the previous proposition (with $d = m + 2$)

$$\gamma(\mathcal{T}) = -(-2)^{m+2-1} = -(-2)^{m+1}.$$

If m is odd, then by the additivity of γ

$$\begin{aligned}\gamma(\mathcal{T}) &= \gamma(\mathcal{U}_1) + \gamma(\mathcal{U}_2) + 2\gamma(\mathcal{U}_1 \cap \mathcal{U}_2) \\ &= \gamma(\mathcal{U}_1) + \gamma(\mathcal{U}_2) - 2(-2)^m \\ &= \gamma(\mathcal{U}_1) + \gamma(\mathcal{U}_2) + (-2)^{m+1}.\end{aligned}$$

□

Remark: The above described subdivision can be thought of the division of a sphere into its hemispheres.

3.2.14 Proposition: *Let Θ be a $(d - 1)$ -dimensional lattice polytope with d odd and \mathcal{T} a unimodular coherent triangulation of it. Let $\mathcal{U}_1, \mathcal{U}_2$ be subcomplexes of $\partial\mathcal{T}$ with the same properties as in the previous proposition (with $\partial\mathcal{T}$ instead of \mathcal{T}). Then*

$$\gamma(\mathcal{T}) = -[\gamma(\mathcal{U}_1) + \gamma(\mathcal{U}_2)].$$

Proof: Using the previous results,

$$\begin{aligned}\gamma(\mathcal{T}) &= (-2)^{d-1} - \gamma(\partial\mathcal{T}) \\ &= (-2)^{d-1} - [\gamma(\mathcal{U}_1) + \gamma(\mathcal{U}_2) + (-2)^{d-1}] \\ &= -[\gamma(\mathcal{U}_1) + \gamma(\mathcal{U}_2)].\end{aligned}$$

□

3.2.15 Corollary: *Let Θ be a 4-dimensional lattice polytope, \mathcal{T} a unimodular coherent triangulation of it and X the 5-dimensional real local Calabi-Yau variety defined by these. Then*

$$\chi(X) = -\kappa(\partial\Theta) + 5l(\partial\Theta) - 16.$$

Proof: Let \mathcal{U}_1 and \mathcal{U}_2 be subcomplexes of $\partial\mathcal{T}$ such that

- $\partial\mathcal{T} = \mathcal{U}_1 \cup \mathcal{U}_2$,
- $|\mathcal{U}_1|, |\mathcal{U}_2| \cong B^3$,
- $|\mathcal{U}_1 \cap \mathcal{U}_2| \cong S^2$,

It is easy to verify that such a subdivision can always be achieved. Furthermore, we can assume without loss of generality that \mathcal{U}_1 and \mathcal{U}_2 are combinatorially equivalent to unimodular triangulations of 3-dimensional lattice polytopes U_1 and U_2 respectively. So

$$\begin{aligned}
\gamma(\mathcal{T}) &= - [\gamma(\mathcal{U}_1) + \gamma(\mathcal{U}_2)] \\
&= - \left[\frac{1}{2} \text{vol}(\partial U_1) + \kappa(U_1) - 5l(U_1) - 3 \right] \\
&\quad - \left[\frac{1}{2} \text{vol}(\partial U_2) + \kappa(U_2) - 5l(U_2) - 3 \right] \\
&= - \text{vol}(U_1 \cap U_2) - \kappa(\partial\Theta) - \kappa(U_1 \cap U_2) \\
&\quad + 5l(\partial\Theta) + 5l(U_1 \cap U_2) + 6 \\
&= - \kappa(\partial\Theta) + 5l(\partial\Theta) + 6 - \text{vol}(U_1 \cap U_2) \\
&\quad - \kappa(U_1 \cap U_2) + 5l(U_1 \cap U_2) \\
&= - \kappa(\partial\Theta) + 5l(\partial\Theta) + 6 - 2\text{vol}(U_1 \cap U_2) + 4l(U_1 \cap U_2) + 2,
\end{aligned}$$

where for the first equality we have used proposition 3.2.5 and for the last one the Euler formula for $U_1 \cap U_2$. From proposition 3.2.13 we have

$$\gamma(\mathcal{U}_1 \cap \mathcal{U}_2) = \text{vol}(U_1 \cap U_2) - 2\kappa(U_1 \cap U_2) + 4l(U_1 \cap U_2) = 8$$

or, equivalently

$$-\text{vol}(U_1 \cap U_2) + 2l(U_1 \cap U_2) + 4 = 8.$$

Thus we get

$$\gamma(\mathcal{T}) = -\kappa(\partial\Theta) + 5l(\partial\Theta) + 8 + 8,$$

and

$$\chi(X) = (-2)^5 + \gamma(\mathcal{T}) = -\kappa(\partial\Theta) + 5l(\partial\Theta) - 16.$$

□

3.2.16 Corollary: *Let Θ be a 4-dimensional lattice polytope that admits a unimodular triangulation. Then*

$$\text{vol}(\Theta) = 2\mu(\Theta) - 5\kappa(\Theta) + 9l(\Theta) - 14,$$

where $\mu(\Theta)$ is the number of 2-dimensional simplices in any unimodular triangulation of Θ .

Proof: Let \mathcal{T} be a unimodular coherent triangulation of Θ and X the associated real local toric Calabi-Yau variety. As the above formula for the Euler characteristic of X and that from proposition 3.2.5 must give the same result we get the equality

$$\begin{aligned} -\kappa(\partial\Theta) + 5l(\partial\Theta) - 16 &= -32 + 16l(\Theta) - 8\kappa(\Theta) \\ &\quad + 4\mu(\Theta) - 2\nu(\Theta) + \text{vol}(\Theta) \\ &= -30 + 14l(\Theta) - 6\kappa(\Theta) + 2\mu(\Theta) - \text{vol}(\Theta), \end{aligned}$$

where $\nu(\Theta)$ is the number of 3-dimensional simplices in any unimodular triangulation of Θ . The statement follows immediately by solving the equation for $\text{vol}(\Theta)$.

□

Real local toric Calabi-Yau varieties that are bundles

Subsequently we will consider the following special situation: \mathcal{T} is a unimodular coherent triangulation of a $(d-1)$ -dimensional lattice polytope Θ such that

$$\sigma^0 := \bigcap_{\sigma \in \mathcal{T}(d-1)} \sigma$$

is a nonempty simplex. By translation we can achieve that the origin is a vertex of σ^0 , so let v_1, \dots, v_n be the remaining vertices (with $n = \dim(\sigma^0)$). By assumption, these are part of a \mathbb{Z} -basis of \mathbb{Z}^{d-1} , say v_1, \dots, v_{d-1} . By applying a lattice transformation we can assume that it is the canonical basis, in particular $\langle v_i, v_j \rangle = 0$ for $i \neq j$.

Let N^0 be the lattice generated by v_1, \dots, v_n and N' the lattice generated by v_{n+1}, \dots, v_{d-1} . Let $\text{pr}' : \mathbb{Z}^{d-1} \rightarrow N'$ be the projection along this basis:

$$\text{pr}'\left(\sum_{k=0}^{d-1} a_k v_k\right) := \sum_{k=n+1}^{d-1} a_k v_k.$$

Let Σ' be the fan in N' consisting of all cones generated by some $\text{pr}'(\sigma)$, $\sigma \in \mathcal{T}$. The following facts are easy to verify:

- (i) pr' maps v_1, \dots, v_n to 0,
- (ii) pr' induces a bijection between $\mathcal{T}(0) \setminus (\sigma^0 \cap \mathbb{Z}^{d-1})$ to generators of the rays of Σ' ,
- (iii) Σ' is a smooth fan.

Note that unimodularity of the triangulation is required for (ii) and (iii) to be true.

Examples: See figures 3.12 and 3.13.

We define the following functions

$$\begin{aligned} \nu_i : \Sigma'(1) &\longrightarrow \mathbb{Z} \\ \rho' &\longmapsto \rho_i, \end{aligned}$$

for $i = 1, \dots, n$, where we set $(\text{pr}')^{-1}(\rho') =: \rho = \sum_{k=0}^{d-1} \rho_k v_k$ and, as before, we identify rays of a fan and their generator.

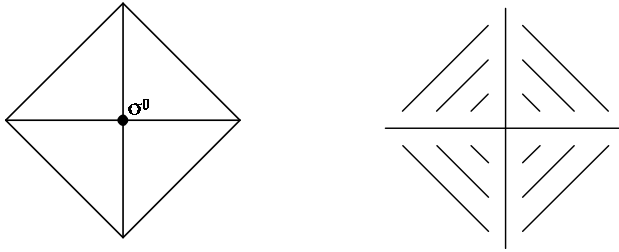

Figure 3.12: Triangulation of Θ and the fan Σ' where σ^0 is 0-dimensional



Figure 3.13: Triangulation of Θ and the fan Σ' where σ^0 is 1-dimensional

3.2.17 Proposition: *In the situation described above, X_Σ is a $(n+1)$ -dimensional vector bundle over $X_{\Sigma'}$, which can be written as a direct sum of line bundles in the following way:*

$$\left(\mathbf{1} - \sum_{i=1}^n \nu_i\right) \oplus \bigoplus_{i=1}^n \nu_i.$$

In particular, if $n = \dim \sigma^0 = 0$, then X_Σ is the anticanonical bundle over $X_{\Sigma'}$.

Proof: We identify \mathbb{Z}^{d-1} with $\mathbb{Z}^{d-1} \times \{1\} \subset \mathbb{Z}^d$, so that $\{v_0, \dots, v_{d-1}\}$ forms a \mathbb{Z} -basis of \mathbb{Z}^d . If $a = \sum_{k=1}^{d-1} a_k v_k \in \mathbb{Z}^{d-1}$, then $a = v_0 + \sum_{k=1}^{d-1} a_k (v_k - v_0)$ in \mathbb{Z}^d . We further note that $\langle v_i, v_j \rangle_{\mathbb{Z}^d} = 1 + \langle v_i, v_j \rangle_{\mathbb{Z}^{d-1}}$ for all i, j .

Clearly pr' extends to \mathbb{Z}^d in a natural way. It is also easy to verify that Σ' can be described as

$$\Sigma' = \{\text{pr}'(\sigma) \mid \sigma \in \Sigma\}.$$

We define a new basis $\tilde{v}_0, \dots, \tilde{v}_{d-1}$ by setting

$$\begin{aligned} \tilde{v}_0 &:= v_0, \\ \tilde{v}_i &:= v_i - v_0 \quad \text{for } i = 1, \dots, d-1. \end{aligned}$$

Let \tilde{p}_i be the respective projections to the i -th coefficient in that basis.

It is easy to verify that $\{\tilde{v}_0, \dots, \tilde{v}_{d-1}\}$ forms an orthonormal basis and that $a \in \mathbb{Z}^{d-1} \times \{1\}$ if and only if $\tilde{p}_0(a) = 1$.

Let $\tilde{\Sigma}$ be the fan obtained from Σ by applying the lattice transformation mapping v_i to \tilde{v}_i for all $i = 0, \dots, d-1$. As $\text{pr}'(v_0) = 0$ and hence $\text{pr}'(\tilde{v}_i) = \text{pr}'(v_i)$ for all i we get

- $\tilde{\Sigma} = \{\text{pr}'(\tilde{\sigma}) \mid \tilde{\sigma} \in \tilde{\Sigma}\}$,
- pr' maps $\tilde{v}_0, \dots, \tilde{v}_n$ to 0,
- pr' induces a bijection between $\tilde{\Sigma}(1) \setminus \{\tilde{v}_0, \dots, \tilde{v}_n\}$ and $\Sigma'(1)$.

$\tilde{\Sigma}$ fulfills all properties of the fan of a direct sum of line bundles over $X_{\Sigma'}$ as described in proposition 2.1.14. Indeed, $\tilde{\Sigma}$ is smooth and generated by its rays (as Σ is) and $(\text{pr}')^{-1}(0) \cap \tilde{\Sigma}(1) = \{\tilde{v}_0, \dots, \tilde{v}_n\}$ are orthonormal. So according to proposition 2.1.14 the line bundles in question are described by the following functions

$$\begin{aligned} \tilde{v}_i : \Sigma'(1) &\longrightarrow \mathbb{Z} \\ \rho' &\mapsto \tilde{p}_i(\tilde{\rho}) \end{aligned}$$

for $i = 0, \dots, n$, where $\rho' = \text{pr}'(\tilde{\rho})$ (see also the commutative diagram in figure 3.14). If $\tilde{\rho}$ is the image of $\rho = v_0 + \sum \rho_k(v_k - v_0) \in \Sigma(1)$,

then

$$\begin{aligned}
 \tilde{\nu}_i(\rho') &= \tilde{p}_i \left(\tilde{v}_0 + \sum_{k=1}^{d-1} \rho_k (\tilde{v}_k - \tilde{v}_0) \right) \\
 &= \begin{cases} 1 - \sum_{k=1}^{d-1} \rho_k, & i = 0, \\ \rho_i, & i \neq 0 \end{cases} \\
 &= \begin{cases} 1 - \sum_{k=1}^n \nu_k(\rho') + \sum_{k=n+1}^{d-1} \rho_k, & i = 0, \\ \nu_i(\rho'), & i \neq 0, \end{cases}
 \end{aligned}$$

so $\tilde{\nu}_i = \nu_i$ for $i = 1, \dots, n$. As the line bundles over $X_{\Sigma'}$ defined by the maps $\rho' \mapsto \rho_k, k \in \{n + 1, \dots, d - 1\}$, are isomorphic to the trivial line bundle, the line bundle described by $\tilde{\nu}_0$ is equivalent to the one described by $\mathbf{1} - \sum_{k=1}^n \nu_k$. So $X_{\tilde{\Sigma}}$ is a sum of line bundles of the desired form, and hence also X_{Σ} , which is related to $X_{\tilde{\Sigma}}$ by a toric isomorphism.

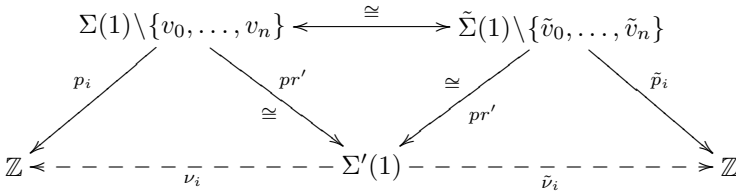

Figure 3.14: Diagram of maps

□

Example: Let Θ be a lattice polytope consisting of two unimodular simplices with a common facet. Then Σ' is the fan belonging to \mathbb{RP}^1 , so $X_{\Sigma'}$ is topologically a circle. Over a circle there are only two topologically different vector bundles of a fixed dimension: the trivial bundle and a “Möbius type” bundle, which is not orientable.

So it follows that $X_\Sigma \cong S^1 \times \mathbb{R}^d$, regardless of how the two simplices are actually arranged.

3.2.18 Proposition: *If $\sigma^0 \cap \text{Int}(\Theta) \neq \emptyset$, the virtual Betti numbers and the non-virtual Betti numbers coincide.*

Proof: It is well-known and can be shown in an elementary way by using a triangulation $\{\Delta_i\}$ of $X_{\Sigma'}$ and a triangulation of X_Σ which is a subdivision of $\{\Delta_i \times \mathbb{R}\}$, that

$$H_c^i(X_{\Sigma'}, \mathbb{Z}/2) \cong H_c^{i+1}(X_\Sigma, \mathbb{Z}/2)$$

for all i and hence $b^i(X_{\Sigma'}) = b^{i+1}(X_\Sigma)$.

On the other hand, for the virtual Poincaré polynomial,

$$\begin{aligned} \beta(X_\Sigma; t) &= \beta\left(\dot{\bigcup}_{\sigma \in \Sigma} O_\sigma; t\right) \\ &= \beta\left(\dot{\bigcup}_{\sigma' \in \Sigma'} (O_{\sigma'} \times \mathbb{R}); t\right) \\ &= \beta(X_{\Sigma'}; t)\beta(\mathbb{R}; t) \\ &= t\beta(X_{\Sigma'}; t). \end{aligned}$$

So, $\beta^i(X_{\Sigma'}) = \beta^{i+1}(X_\Sigma)$ for all i .

Σ' is a complete and smooth fan, so $X_{\Sigma'}$ is nonsingular and compact. Hence the virtual and non-virtual Betti numbers coincide on $X_{\Sigma'}$ and thus also on X_Σ . \square

3.2.19 Conjecture: *Let X be a real local toric Calabi-Yau variety. Then the virtual and non-virtual Betti number of X coincide, that is*

$$\beta^i(X) = b^i(X)$$

for all $i \geq 0$.

Remark: There is some evidence to the conjecture, given by the above result and the fact that the conjecture is true for dimensions 3 and less (as we will show in the subsequent sections). Furthermore, virtual and non-virtual Betti numbers coincide for $i = 0$ and $i = \dim X$, as $\beta^0(X) = b^0(X) = 0$, $\beta^{\dim X}(X) = b^{\dim X}(X) = 1$.

If the conjecture were true, it would not only yield an easy way for computing the (non-virtual) Betti numbers of a smooth real local toric Calabi-Yau variety, but it would also impose that they are independent of the triangulation defining the variety.

So, a weaker form of the above conjecture is the following:

3.2.20 Conjecture: *The Betti numbers of a real local toric Calabi-Yau variety depend only on the lattice polytope used for its definition and not on its triangulation.*

3.3 2-Dimensional Varieties

3.3.1 Theorem: *Let $d = 2$, $\Theta = [0, n]$ and let X_Σ be the corresponding real local toric Calabi-Yau variety. Then X_Σ is homeomorphic to $T_g \setminus \{k \text{ pts.}\}$ with*

$$\begin{cases} g = \frac{n-1}{2}, k = 1, & n \text{ odd} \\ g = \frac{n}{2} - 1, k = 2, & n \text{ even.} \end{cases}$$

Thereby T_g denotes the orientable closed surface of genus $g \geq 0$.

Proof: Let $\overline{X_\Sigma}$ be the compactification of X_Σ . The boundary of $\overline{X_\Sigma}$ is a closed 1-dimensional manifold, so it consists of a finite number k of circles. To each circle we can attach a disc. The result is a smooth closed, still orientable, manifold of dimension 2. We denote it with T_g , where g is its genus. Then it is clear by the construction that X_Σ is homeomorphic to $T_g \setminus \{k \text{ pts.}\}$, so it remains to determine the parameters g and k .

If n is even then $\{0, n\} = \partial\Theta$ generates the subgroup $\{0\} \subset \mathbb{Z}/2$ of index 2. So by theorem 3.2.7 $k = 2$. If n is odd, then the full

group $\mathbb{Z}/2$ is generated, so the index, and also k , is 1. Using the Euler characteristic of X_Σ , which gives a further relation between the parameters of the construction, we get

$$\chi(X_\Sigma) = 2 - n = \chi(T_g) - k \cdot \chi(\text{pt.}) = 2 - 2g - k.$$

If we substitute the respective values for k in the two cases, the assertion follows. \square

Remark: When the parameter n of the construction is augmented by 1, two different things can happen: If n is odd, then the number of “holes” in X (that means the parameter k), augments from one to two. If n is even, then the number of holes decreases from two to one and the genus increases by one. This different behavior is quite interesting in view of the fact that the difference between the two surfaces is in both cases identical, namely a one-dimensional torus orbit. Figures 3.15 and 3.16 give a sketch where this additional orbit is placed with respect to the surface (note that in figure 3.15 the surface is represented by its fundamental polygon). In both cases it “materializes” in some part of the boundary circle(s) of X (more precisely, of \overline{X}), connecting two formerly distant regions of X . The effect of this process is in one case a division of the hole (fig. 3.15), in the other case a “bending” of the surface to form an additional handle with the effect that the two holes get “connected” to form a single one (fig. 3.16).

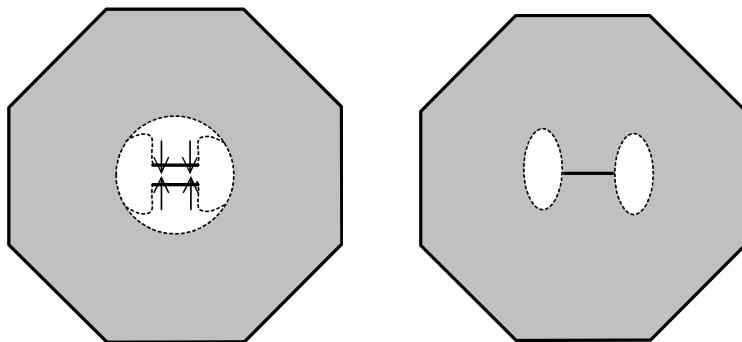

Figure 3.15: Change when passing from n to $n + 1$, where n is odd

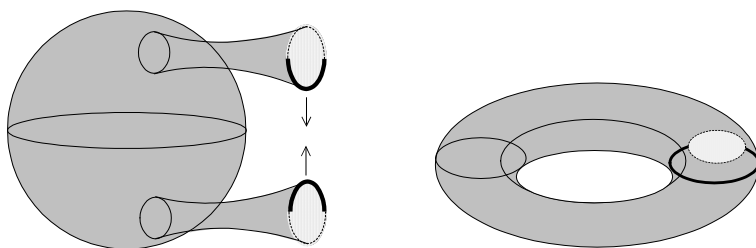

Figure 3.16: Change when passing from n to $n + 1$, where n is even

3.4 3-Dimensional Varieties

In the following we calculate the homology and cohomology groups of 3-dimensional real local toric Calabi-Yau varieties by using the presentation of the fundamental group with generators and relations as described by V. Uma ([Uma]). Let X be such a variety. We introduce the following notation:

We write $H_1(X, \mathbb{Z})$ for $\pi_1(X)/[\pi_1, \pi_1]$. Then, for the cohomology group with compact support we have $H_c^2(X, \mathbb{Z}) \cong H_1(X, \mathbb{Z})$. We show that $H_c^2(X, \mathbb{Z}/2)$ is independent of the triangulation of the defining lattice polytope of the variety (whereas with integral coefficients it is not). As the same is valid for the Euler characteristic, we can calculate all Betti numbers in terms of the defining lattice polytope.

3.4.1 Theorem: *Let X be a 3-dimensional real local Calabi-Yau variety, assigned to a lattice polytope $\Theta \subset \mathbb{R}^2$ and a unimodular coherent triangulation \mathcal{T} . Then $H_1(X, \mathbb{Z}) \cong \mathbb{Z}^r \times (\mathbb{Z}/2)^s$, where r, s are nonnegative integers such that $r + s + 3 = l(\Theta) = \#\mathcal{T}(0)$. Furthermore,*

$$s = \#\{v \in \mathcal{T}(0) \mid v \in \text{Int}(\Theta)\} - \#\{v \in \mathcal{T}(0) \mid \text{star}(v) \text{ is of type IIa}\},$$

where $\text{star}(v)$ is said of type IIa, if $\dim_2(\partial(\text{star}(v))) = 1$ and of type IIb otherwise (this designation will become clear in the proof).

For $b^i := \dim H_c^i(X, \mathbb{Z}/2)$ we have

$$\begin{aligned} b^0 &= 0, \\ b^1 &= l(\text{Int } \Theta), \\ b^2 &= l(\Theta) - 3, \\ b^3 &= 1. \end{aligned}$$

Remark: The numbers r and s depend on the triangulation as can be seen in the following example, whereas the Betti numbers are independent.

If v is an interior vertex of the triangulation, then there is mainly only one type of complex which can be a star of type IIa. It consists of four triangles as seen in figure 3.20. The other possibilities are derived from this one by a change of basis and translating the vertices by elements in $(2\mathbb{Z})^2$.

Example: Consider the following two triangulations of the same polytope:

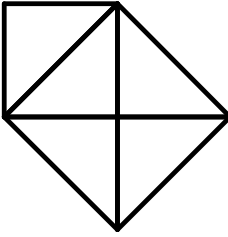

Figure 3.17: Triangulation
A

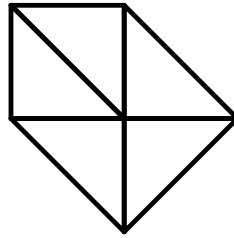

Figure 3.18: Triangulation
B

In the first example, $H_1(X_1) \cong \mathbb{Z}^3$. In the second example, $H_1(X_2) \cong \mathbb{Z}^2 \times \mathbb{Z}/2$.

Proof: If in the first example we leave out the upper left simplex the corresponding real local toric Calabi-Yau variety is homeomorphic to the trivial line bundle over $\mathbb{P}^1 \times \mathbb{P}^1$, hence has fundamental group \mathbb{Z}^2 . As we will see in the proof of the theorem, addition of one more simplex as in this example leads to one more free variable, so $H_1(X_1) \cong \mathbb{Z}^2 \times \mathbb{Z} = \mathbb{Z}^3$.

The second example is a (nontrivial) line bundle over the non-oriented surface of genus -1 (a projective plane with one handle), so they both have $\mathbb{Z}^2 \times \mathbb{Z}/2$ as the first homology group. \square

For the proof of the theorem we will need the following preliminary result:

3.4.2 Proposition: Let $\Theta \subset \mathbb{R}^2$ be a lattice polytope and \mathcal{T} a lattice triangulation (not necessarily unimodular). Then there is a numbering $\sigma_0, \dots, \sigma_n$ for the triangles in \mathcal{T} , such that for any $i \in \{1, \dots, n\}$ the triangle σ_i is attached to $\Theta_{i-1} := \bigcup_{j=0}^{i-1} \sigma_j$ in one of the following ways:

I) σ_i has exactly one additional vertex and two additional edges (so Θ_{i-1} and σ_i have one common edge).

II) σ_i has no additional vertices and exactly one additional edge.

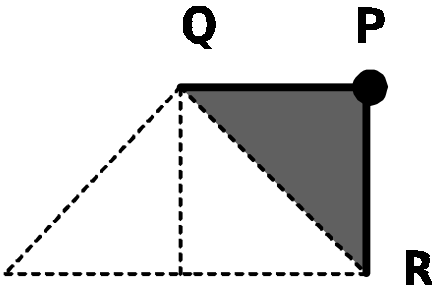

Figure 3.19: Attachment I)

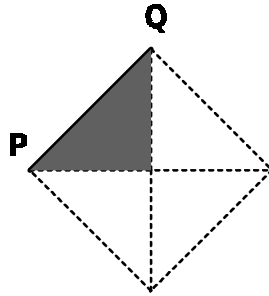

Figure 3.20: Attachment II)

Proof: Clearly, we can choose a numbering on \mathcal{T} , such that all Θ_i consist of one component.

In a first step we show that we can further choose the triangles in such a way that the Euler characteristic is always preserved, that is, all Θ_i are contractible.

If this were not the case, say $\chi(\Theta_{i-1}) = 1$ and $\chi(\Theta_i) \leq 0$ for some i (the Euler characteristic cannot become larger, as the Θ_i have only one component), the boundary $\partial\Theta_i$ would have several components, which are circles. Let us denote the components that bound compact sets in the complement (in \mathbb{R}^2) of Θ_i by $\mathcal{S}_1, \dots, \mathcal{S}_t$. In the following we will call them *inner boundaries*, in contrast to the

outer boundary that bounds a non-compact part of the complement. As Θ is convex, the inner boundary components respectively bound non-empty subcomplexes of \mathcal{T} , which we denote by $\mathcal{B}_1, \dots, \mathcal{B}_t$. Let m_k be the number of simplices in \mathcal{B}_k for $k = 1, \dots, t$ and assume that m_1 is the smallest of them.

We choose σ_i in such a way that the resulting m_1 is minimal among all choices. Then we replace σ_i by any $\tilde{\sigma}_i \in \mathcal{B}_1$ with $\tilde{\sigma}_i \cap \mathcal{S}_1 \neq \emptyset$ (such a simplex must exist as Θ is convex). As $\mathcal{B}_1 \setminus \{\tilde{\sigma}_i\}$ has less simplices than \mathcal{B}_1 , by assumption on the minimality $\tilde{\Theta}_i := \Theta_{i-1} \cup \tilde{\sigma}_i$ cannot have inner boundary, so it has Euler characteristic 1.

There remain just three possibilities of attaching a simplex σ_i to an already constructed Θ_{i-1} (the number of additional edges must exceed the number of additional vertices by 1). Apart from the already mentioned constructions I) and II), one can add a simplex with two additional vertices and three additional edges (see figure 3.21). Set $R = \sigma_i \cap \Theta_{i-1}$, let Q be a second vertex of σ_i , and T the lattice point on $\partial\Theta_{i-1}$ that is joined to R by an edge and lies “on the side of Q ”. By convexity of Θ the triangle RQT lies in Θ . In particular, it contains a triangle of \mathcal{T} having edge RT and not lying inside Θ_{i-1} . So we can proceed with the numbering with a triangle which falls into category I).

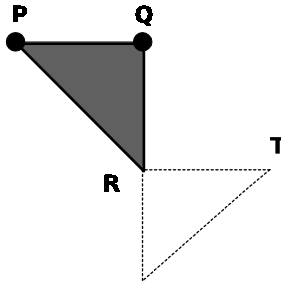

Figure 3.21: Attachment with two new vertices and three edges

□

Remark: Note that in case II the two triangles having a common edge with the new triangle cannot be “isolated”, but must each have at least one further common edge with a triangle in Θ_{i-1} (this is easily seen by induction).

Proof of the theorem: In the proof we will have to analyze the presentation of the fundamental group of X as given by Uma (see proposition 2.2.3). We recall the result in terms of the special situation treated here and thereby fix a more convenient notation: To each lattice point P in Θ “belong” 8 generators, which we will designate with $y_P^{\varepsilon_1, \varepsilon_2, \varepsilon_3}$, where the upper index is an element of $(\mathbb{Z}/2)^3$. Instead of 0 and 1 we write + and -. So a typical generator would be y_P^{+++} .

There are relations of length one, two and four, called types (A), (B) and (C). The relations (A) and (B) depend only on the vertices (and relate its generators), the relations of type (C) depend on the edges and relate the generators of the vertices belonging to it. We will use here an additive notation to describe them, as we are only interested in the homology groups. The relations of type (B) and (C) for the situation of an elementary triangle with vertices P , Q and R are then as follows:

Relations of type (B):

$$\begin{aligned} y_P^{+, \varepsilon_2, \varepsilon_3} + y_P^{-, \varepsilon_2, \varepsilon_3} &= 0 \\ y_Q^{\varepsilon_1, +, \varepsilon_3} + y_Q^{\varepsilon_1, -, \varepsilon_3} &= 0 \\ y_R^{\varepsilon_1, \varepsilon_2, +} + y_R^{\varepsilon_1, \varepsilon_2, -} &= 0, \end{aligned}$$

where $(\varepsilon_1, \varepsilon_2, \varepsilon_3)$ run through $(\mathbb{Z}/2)^3$.

Relations of type (C):

$$\begin{aligned} y_P^{+++} + y_P^{--} + y_Q^{+-} + y_Q^{-++} &= 0 \\ y_P^{+-} + y_P^{--} + y_Q^{+-} + y_Q^{-+-} &= 0 \\ y_P^{+-} + y_P^{++} + y_Q^{++} + y_Q^{-+-} &= 0 \\ y_P^{+-} + y_P^{-+-} + y_Q^{+-} + y_Q^{--} &= 0 \end{aligned} \tag{PQ}$$

$$\begin{aligned}
y_P^{+++} + y_P^{-+-} + y_R^{+--} + y_R^{-++} &= 0 \\
y_P^{+-+} + y_P^{---} + y_R^{+--} + y_R^{-++} &= 0 \\
y_P^{+--} + y_P^{-++} + y_R^{-+-} + y_R^{+++} &= 0 \\
y_P^{+--} + y_P^{-++} + y_R^{---} + y_R^{+-+} &= 0
\end{aligned} \tag{PR}$$

$$\begin{aligned}
y_Q^{+++} + y_Q^{+--} + y_R^{+--} + y_R^{+-+} &= 0 \\
y_Q^{-++} + y_Q^{---} + y_R^{-+-} + y_R^{-++} &= 0 \\
y_Q^{+--} + y_Q^{-++} + y_R^{+--} + y_R^{+++} &= 0 \\
y_Q^{-+-} + y_Q^{-++} + y_R^{---} + y_R^{-++} &= 0
\end{aligned} \tag{QR}$$

From the relations of type (B) we immediately get that the number of independent generators belonging to a point is reduced to four. If we use those with $\varepsilon_1 = +$ as representatives for the generators belonging to P , with $\varepsilon_2 = +$ for those belonging to Q and $\varepsilon_3 = +$ for those belonging to R , the relations of type (C) become:

$$\begin{aligned}
y_P^{+++} - y_P^{+-+} - y_Q^{+++} + y_Q^{-++} &= 0 \\
y_P^{+--} - y_P^{+--} - y_Q^{+--} + y_Q^{-+-} &= 0
\end{aligned} \tag{PQ'}$$

$$\begin{aligned}
y_P^{+++} - y_P^{+--} - y_R^{+++} + y_R^{-++} &= 0 \\
y_P^{+-+} - y_P^{+--} - y_R^{+-+} + y_R^{-++} &= 0
\end{aligned} \tag{PR'}$$

$$\begin{aligned}
y_Q^{+++} - y_Q^{+--} - y_R^{+++} + y_R^{+-+} &= 0 \\
y_Q^{-++} - y_Q^{-+-} - y_R^{-++} + y_R^{-++} &= 0
\end{aligned} \tag{QR'}$$

The third and fourth equation of each original block become the same as the first two (up to multiplication by -1).

The proof of the theorem is done by a type of induction by the number of triangles in \mathcal{T} . As we have shown in the previous propo-

sition, we can gradually build up any convex lattice polytope Θ with its triangulation by starting with an arbitrary triangle $\sigma_0 \in \mathcal{T}$ and in each step adding a triangle in the form I) or II).

The intermediate simplicial complexes may not be convex polytopes, but we can treat them in the same manner (the corresponding varieties are generalized real local toric Calabi-Yau varieties). So let X and X' be the corresponding varieties associated with the sub-complexes Θ_{i-1} and Θ_i , respectively (where $i \in \{1, \dots, n\}$).

There is a well defined homomorphism $H_1(X) \rightarrow H_1(X', \mathbb{Z})$ which maps each generator in $H_1(X, \mathbb{Z})$ to “itself” (that is the generator with the same designation in $H_1(X', \mathbb{Z})$). It is well defined because the relations for $H_1(X, \mathbb{Z})$ are also included in the set of relations for $H_1(X', \mathbb{Z})$.

In the case that Θ_i differs from Θ_{i-1} by a construction of type I) this is a monomorphism: Finding an element of the kernel is equivalent to the problem of eliminating all generators belonging to the new point P by using the relations (PQ) and (PR), respectively (PQ') and (PR'). In other words, we have to find a nontrivial solution for the system of linear equations

$$(a, b, c, d) \begin{pmatrix} 1 & 0 & -1 & 0 \\ 0 & 1 & 0 & -1 \\ 1 & -1 & 0 & 0 \\ 0 & 0 & 1 & -1 \end{pmatrix} = 0,$$

where the columns of the matrix represent the coefficients of y_P^{++++} , y_P^{+-} , y_P^{+-} and y_P^{--} (in this order) and the rows represent the part of the relations (PQ') and (PR') which contains generators belonging to P .

It is not difficult to check that the rank of the matrix is 3, and the unique solution to the equation (up to a scalar multiple) is $(1, 1, -1, -1)$. So the corresponding relation, where the generators

belonging to P vanish, is

$$y_P^{+++} + y_P^{-++} + y_Q^{+--} + y_Q^{-++} - (y_P^{+--} + y_P^{---} + y_Q^{+--} + y_Q^{-+-}) - (y_P^{+++} + y_P^{-+-} + y_R^{+--} + y_R^{-++}) + y_P^{+--} + y_P^{---} + y_R^{+--} + y_R^{-+-} = 0$$

This expression simplifies to

$$y_Q^{+--} + y_Q^{-++} - y_Q^{+--} - y_Q^{-+-} - y_P^{+--} - y_P^{-++} + y_P^{+--} + y_P^{-+-} = 0$$

which is the sum of the two relations from (QR). So, no new relations can be added to $H_1(X, \mathbb{Z})$ and the homomorphism is indeed injective.

In case II) it is obvious that there are no additional generators but additional relations introduced by the additional edge, so $H_1(X', \mathbb{Z})$ will be a factor group of $H_1(X, \mathbb{Z})$.

Now we turn to case I) and consider $H_1(X', \mathbb{Z})/H_1(X, \mathbb{Z})$: The generators belonging to the points Q and R vanish and there remain the following relations for the four additional generators belonging to P (always two are identified by the relations of type (B)):

$$\begin{aligned} y_P^{+++} + y_P^{-++} &= 0 \\ y_P^{+--} + y_P^{---} &= 0 \end{aligned} \quad (\text{PQ})$$

$$\begin{aligned} y_P^{+++} + y_P^{-+-} &= 0 \\ y_P^{+--} + y_P^{---} &= 0 \end{aligned} \quad (\text{PR})$$

It is not difficult to see that three of these relations are independent, leaving just one free generator, e.g. $y_P^{+++} =: y$. The seven other variables with different upper indices are related to y as follows (*):

+++	++-	+-+	+--	-++	-+-	--+	---
y	y	y	y	y^{-1}	y^{-1}	y^{-1}	y^{-1}

So $H_1(X', \mathbb{Z})/H_1(X, \mathbb{Z}) \cong \mathbb{Z}$.

In case II) there are two different subcases:

a) A situation exactly as in figure 3.20 (up to a change of basis): four triangles, whose outer vertices form a sublattice of index 2.

Without loss of generality we can assume that \mathcal{T} and \mathcal{T}' consist of just the mentioned triangles (further triangles would not impose relations on the generators belonging to P and Q). But as $X' \cong T_1 \times \mathbb{R}$, $H_1(X, \mathbb{Z}) \cong H_1(X', \mathbb{Z}) \cong \mathbb{Z}^2$, so no additional relations are added in this case.

b) In all other cases with four triangles X' is a (non-trivial) line bundle over the non-orientable surface of genus $\#\mathcal{T}'(2) - 3$ and Euler characteristic $4 - \#\mathcal{T}'(2)$, hence $H_1(X', \mathbb{Z}) \cong \mathbb{Z}^{\#\mathcal{T}'(2)-3} \times \mathbb{Z}/2$. But on the other hand, the dimension of $H_1(X, \mathbb{Z})$ is equal to $\#\mathcal{T}(2) - 1 = \#\mathcal{T}'(2) - 3 + 1$, so there is a new relation making one generator be of order 2.

It is not difficult to verify that the addition of a triangle by type II occurs exactly once per inner vertex of the triangulation (e.g. we can choose a special numbering by starting with all triangles having one inner vertex in common, then move on to the next inner vertex, and so on). So s is the number of times IIb occurs, which can be expressed as the number of times II, but not IIa, occurs.

To conclude the proof of the theorem we remark that the relations of type (A) of 2.2.3 have the only effect that they make the generators belonging to the vertices of the “first” simplex vanish. As we have shown, all further simplices that bring exactly one new vertex introduce also exactly one new (free) generator. This generator never vanishes by adding further relations, but can possibly be made to have order 2 by a new simplex without new vertices. These do not introduce new generators. So $H_1(X, \mathbb{Z})$ is generated by $l(\Theta) - 3$ variables, which are free or of order 2 and do not have further relations.

□

3.4.3 Proposition: *Let $\Theta \subset \mathbb{R}^2$ be a lattice polytope, \mathcal{T} a unimodular coherent triangulation, and X the associated real local Calabi-*

Yau variety. Then the virtual and non-virtual Betti numbers of X coincide, that is $\beta^i(X) = b^i(X)$ for $i = 0, \dots, 3$.

Proof: The proof will proceed by induction on the number of triangles in \mathcal{T} . The assertion is obviously true, if Θ is an elementary simplex (and $\#\mathcal{T}(2) = 1$).

Now assume that the assertion is true for Θ, \mathcal{T} and X and \mathcal{T}' is a lattice polytope with unimodular triangulation such that \mathcal{T}' has exactly one more triangle than \mathcal{T} . As shown previously (see proposition 3.4.2), we can assume that the additional triangle σ is attached to Θ in one of the two following ways:

- I) σ adds one new vertex and two new edges.
- II) σ adds no new vertex and one new edge.

In case I), it is an easy consequence of proposition 3.2.6 that

$$\begin{aligned} \beta(X'; t) - \beta(X; t) &= \sum_{k=0}^2 (t-1)^{2-k} (\#\mathcal{T}'(k) - \#\mathcal{T}(k)) \\ &= (t-1)^2 + 2(t-1) + 1 \\ &= t^2. \end{aligned}$$

So, $\beta^2(X') = \beta^2(X) + 1$, whereas $\beta^i(X') = \beta^i(X)$ for all $i \neq 2$.

In case II), by the same reasoning

$$\begin{aligned} \beta(X'; t) - \beta(X; t) &= (t-1) + 1 \\ &= t. \end{aligned}$$

So, $\beta^1(X') = \beta^1(X) + 1$, whereas $\beta^i(X') = \beta^i(X)$ for all $i \neq 1$.

It is easy to verify with proposition 3.4.1 that in both cases virtual and non-virtual Betti numbers behave in the same way. \square

It is to be noted that the effects on cohomology by adding new triangles reflect a certain topological operation on the variety. As at the starting point of this process all varieties are homeomorphic

(namely to \mathbb{R}^3 , corresponding to a single triangle), this leads to the following idea: If we can build up two different lattice polytopes and respective triangulations in such a way that in each step the same type of triangle addition occurs (when it still has to be determined what this exactly means), then the two varieties are homeomorphic. We state the following more precise conjecture:

3.4.4 Conjecture: *Let $\Theta \subset \mathbb{R}^2$ be a lattice polytope, \mathcal{T} a unimodular coherent triangulation of it and X the associated real local Calabi-Yau variety. Denote by A the set of inner vertices of the triangulation.*

Then the topology of X is characterized by the following information on \mathcal{T} :

- *the number of inner edges of \mathcal{T} which do not contain any inner point,*
- *$f : A \rightarrow \tilde{\mathbb{N}}$, where $f(v)$ is defined to be the number of triangles in $\text{star}(v)$, with additional differentiation if this number is four: If $\text{star}(v)$ is like figure 3.20, then $f(v) := 4_a$, otherwise $f(v) := 4_b$.*
- *$g : A \times A \rightarrow \{0, 1\}$, where we set $g(v, w) = 1$ if $\text{star}(v) \cap \text{star}(w)$ is a 2-dimensional triangle and $g(v, w) = 0$ otherwise.*

So, two 3-dimensional smooth real local toric Calabi-Yau varieties are homeomorphic if and only if there is a bijection on the inner vertices of the triangulations, such that the above information are equal for both varieties.

The fundamental group of the varieties is uniquely determined by the same information. It follows that two 3-dimensional smooth real local toric Calabi-Yau varieties are homeomorphic if and only if their fundamental groups are isomorphic.

Evidences: We use the same type of induction as in the proof of theorem 3.4.1 and use the same notation. So, let $\mathcal{T}, \mathcal{T}'$ be unimodular coherent simplicial complexes such that \mathcal{T}' is obtained from \mathcal{T}

by addition of a triangle. We can assume that the Euler characteristic of $|\mathcal{T}| = |\mathcal{T}'| = 1$. Let X, X' be the associated real local toric Calabi-Yau varieties. We note (without proof) that theorem 3.2.7 still holds in this situation (with some care taken on the definition of the compactification).

The description of the topological operation corresponding to the addition of a triangle is best done on the compactification \overline{X} of X (we can recover the operation on X by throwing away the boundary).

We recall that the attachment of a p -handle to a compact manifold-with-boundary Y means glueing $B^p \times B^q$ (with $p + q = \dim Y$) to the boundary of Y by identifying $S^{p-1} \times B^q \subset \partial(B^p \times B^q)$ with a homeomorphic part of the boundary of Y ³. The result of this attachment depends on two choices: the choice of a $S^{p-1} \times B^q$ in ∂Y and the choice of a self-homeomorphism of $S^{p-1} \times B^q$. Up to homeomorphism, though, the results of two such p -handle attachments (on Y) are homeomorphic if the $S^{p-1} \times B^q$ are isotopic in ∂Y and the two homeomorphisms can be extended to $B^p \times B^q$ (the latter is in particular true if the homeomorphisms are homotopic).

The addition of a simplex of type I corresponds to the attachment of a 1-handle. This follows from the orbit decomposition, which states that $X' \setminus X$ is an open 2-disc. This disc can, by the universality of the compactification (see proposition 1.1.30) be seen as two different discs in $\partial \overline{X}$, which are then glued together.

The addition of a simplex of type II corresponds to the attachment of a 2-handle: From the orbit decomposition we get that $X' \setminus X$ is a line, which takes the role of B^1 . A tubular neighbourhood of B^1 can be viewed as $B^1 \times B^2$. Again, we can assume that the attachment takes place in $\partial \overline{X}$.

In the case of type I (attaching a 1-handle) there are essentially two possibilities for the homeomorphisms on $\{-1\} \times B^2$ and $\{+1\} \times B^2$ (both lie inside $[-1, 1] \times B^2$):

³this can be done via a homeomorphism, p.l. homeomorphism or diffeomorphism, depending on the category of manifolds. To simplify matters, we will henceforth only talk of homeomorphisms.

- (i) Both are orientation-preserving.
- (ii) One is orientation-preserving, the other one is not.

With ii) the resulting manifold is not orientable. So in our case this cannot happen.

If $\partial\bar{X}$ is connected, then the two attaching discs can be moved freely. There remains no other freedom of choice. If $\partial\bar{X}$ is not connected, then by theorem 3.2.7 it consists of two components and $\partial\bar{X}'$ is connected. It follows that the 1-handle must connect the 2 components of $\partial\bar{X}$, so one disc lies on one component, the other one on the other component. No choice is possible here, either.

We conclude that the topological operation on X which corresponds to the addition of a simplex of type I to \mathcal{T} is uniquely defined by X .

In the case of type II (attaching a 2-handle) any self-homeomorphism on $S^1 \times [-1, 1]$ can be extended to $B^2 \times [-1, 1]$, so we need only to investigate the position of the $S^1 \times [-1, 1]$ in $\partial\bar{X}$. As $\partial\bar{X}$ must be connected (by theorem 3.2.7), the result of the handle attachment depends only on the element of $\pi_1(\partial\bar{X})$ represented by the $S^1 = S^1 \times \{0\} \subset S^1 \times [-1, 1]$.

In the following we show how this works out in case that X and X' are bundles, that is $\bigcap_{\sigma \in \mathcal{T}'(2)} \sigma = \{pt\}$. We further show the effects of the operation on the fundamental group of X , when from 2.2.3 we know that we can assign to each vertex of the triangulation one generator of $\pi_1(X)$ (with the exception that 3 of them are considered to be the neutral element). From the same proposition we also know that the addition of the triangle of type II introduces no further generator but a relation of type $aba^\delta b^{\delta'}$, where a and b are the generators assigned to the vertices connected by the new edge and $\delta, \delta' \in \{\pm 1\}$. On the other hand, the new relation is just the image of the $[S^1]$ under the map $\pi_1(\partial\bar{X}) \rightarrow \pi_1(\bar{X})$ induced by the inclusion.

Type IIa (see figure 3.22):

By the above considerations on the addition of simplices of type I, \bar{X} is a solid 2-torus, $\bar{X}' = [-1, 1] \times T_1$, $\partial\bar{X} = T_2$, $\partial\bar{X}' = T_1 \cup T_1$,

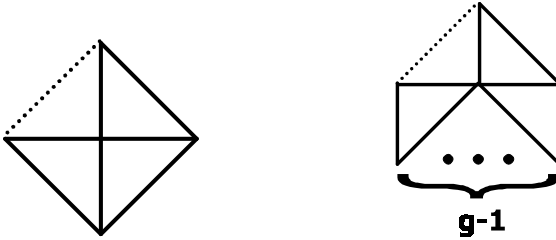

Figure 3.22: Addition of a triangle of type IIa

Figure 3.23: Addition of a triangle of type IIb

$$\pi_1(X) \cong \pi_1(X') \cong \mathbb{Z} * \mathbb{Z}, \pi_1(\partial\bar{X}) = \langle a, b, c, d \mid aba^{-1}b^{-1}cdc^{-1}d^{-1} \rangle.$$

We can also view X as the trivial line bundle over $T_1 \setminus \{pt.\}$ (by the orbit decomposition) and the topological operation in question is the addition of the line bundle over the missing point. The situation is depicted in figures 3.24 and 3.25, whence it becomes clear that the new relation is $aba^{-1}b^{-1}$, which is concordant with the fact that it becomes trivial under abelianization.

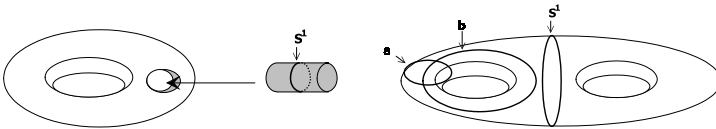

Figure 3.24: The operation $\bar{X} \rightarrow \bar{X}'$ of type IIa. $\partial\bar{X}$ consists of one T_1 outside and one T_1 inside, connected by a tube

Figure 3.25: Position of the S^1 in $\partial\bar{X}$. \bar{X} is not the solid 2-torus

Type IIIb (see figure 3.23):

Let \mathcal{T} consist of $g + 1$ triangles. \bar{X} is a solid $(g - 1)$ -torus, \bar{X}' is the orientation bundle over $S^2 \# (g - 1)\mathbb{R}\mathbb{P}^2 \cong T_{\lfloor \frac{g-1}{2} \rfloor} \# k\mathbb{R}\mathbb{P}^2$ with $k \in \{1, 2\}$ and $k \equiv g - 1 \pmod{2}$, $\partial\bar{X} = T_{g-1}$, $\partial\bar{X}' = T_{g-2}$, $\pi_1(X) =$

$\langle x_1, \dots, x_{g-1} \rangle$, $\pi_1(X') = \langle x_1, \dots, x_{g-1} \mid z^2 = w \rangle$, where $z = x_1$ and $w = x_2 x_3 x_2^{-1} x_3^{-1} \dots x_{g-2} x_{g-1} x_{g-2}^{-1} x_{g-1}^{-1}$ if g is even and $z = x_1 x_2$, $w = x_3 x_4 x_3^{-1} x_4^{-1} \dots x_{g-2} x_{g-1} x_{g-2}^{-1} x_{g-1}^{-1}$ if g is odd. $\pi_1(\partial\bar{X}) = \langle a_1, b_1, \dots, a_{g-1}, b_{g-1} \mid a_1 b_1 a_1^{-1} b_1^{-1} \dots a_{g-1} b_{g-1} a_{g-1}^{-1} b_{g-1}^{-1} \rangle$ and $\pi_1(\bar{X}')$ is similar with $g-2$ instead of $g-1$.

From the description of $\pi_1(X')$ we get that the new relation introduced by the addition of the triangle to \mathcal{T} must be of the form: (a) x^2 , if $g = 2$, (b) $xyxy$ if $g = 3$ and $xyx^{-1}y$ if $g > 3$. So, the class of $[S^1]$ in $\pi_1(\partial\bar{X})$ must map to an expression of this form in $\pi_1(\bar{X})$. There are different possibilities of doing so (accounting for the elements of $\pi_1(\partial\bar{X})$ which can be contracted in \bar{X}), but as we are in a precise situation (for fixed g), this is done in a unique way (similar to above, one can use the orbit decomposition to determine it). In figure 3.26 we have shown how this works out for $g = 2$, when \bar{X} is the solid 1-torus, X' the orientation bundle on $\mathbb{R}\mathbb{P}^2$ and the $S^1 \subset \partial\bar{X}$ is homotopic to a^2b (where a, b are the standard generators and b contracts in \bar{X}).

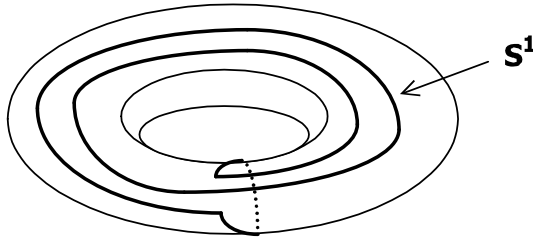

Figure 3.26: $\partial\bar{X}$ in case of type IIb, with the S^1 determining the attachment of the 2-handle

Returning to our classification problem, we note that two triangulations \mathcal{T} and \mathcal{T}' coincide on the above described combinatorial data if and only if there are numberings of the 2-dimensional simplices with the following properties:

- (i) $v_i \in \mathcal{T}(2)$ is of type I/IIa/IIb $\iff v'_i \in \mathcal{T}'(2)$ is of type I/IIa/IIb,
- (ii) v_i “completes” $\text{star}(v)$ and $g(v, w) = 1$ for some $w \iff v'_i$ “completes” $\text{star}(v')$, $g(v', w') = 1$ and $f(w) = f(w')$

(This is easy to verify). Moreover, we can assume that \mathcal{T}' has no minimal inner 1-Simplex (as the topological operation in case of the addition of a triangle of type I is uniquely defined) and we need only to care about the addition of triangles of type II. The topological operation in this case behaves locally as described above (for bundles). In this local picture now also other handle attachments come into account. By the orbit decomposition, for a star v these are all star w with $g(v, w) = 1$. We don't know a good way how to determine the relative positions of the handle attachments, but we believe that it is already enough to know all those star w and to know $f(w)$. This would then already imply the first statement of the conjecture.

For the second statement on the fundamental groups we note the following: If we have two different “building-ups” of triangulations \mathcal{T} and \mathcal{T}' then we get two different presentations of fundamental groups. On the other hand, the presentations follow the same principles (i.e. there is a set of generators associated with vertices of the triangulation and some relations each of which involves all generators belonging to a star v), so one expects that fundamental groups with different presentations should be non-isomorphic. This would imply the second statement of the conjecture, but we have no proof.

We cannot fill the gaps at the moment, but we note that the conjecture fits into a more general picture: The compactifications of 3-dimensional real local toric Calabi-Yau varieties belong to a class of manifolds which are called Haken 3-manifolds (see [HGT], 3.3.5 for the definition and the subsequent statement). It is known that two Haken 3-manifolds are homotopically equivalent if and only if their fundamental groups are isomorphic. Moreover, it is known that a homotopy equivalence between two compact Haken 3-manifolds which on the boundaries restricts to a homeomorphism is homotopic to a homeomorphism (the condition on the boundary can be weakened

but not omitted). So, if our conjecture regarding the fundamental groups were true, it would follow that two real local toric Calabi-Yau varieties coinciding on the above described combinatorial information are homotopy equivalent. From this, it would *not* follow that they are indeed homeomorphic as we do not know how the homotopy equivalence behaves on the boundary. Nevertheless, it would not be surprising if the conjecture were true.

IV Real Compact Calabi-Yau Toric Hypersurfaces

4.0.1 Definition: A compact smooth projective complex algebraic variety X is called a *complex Calabi-Yau variety* if it has trivial canonical bundle and $H^i(X, \mathcal{O}_X) = 0$ for all $i = 1, \dots, \dim X - 1$. A real algebraic variety X is a *real Calabi-Yau variety* if its complexification is a (complex) Calabi-Yau variety.

If $\dim X = 1$ then X is called an *elliptic curve*, if $\dim X = 2$ it is called a *K3 surface*.

4.1 Construction of Calabi-Yau Toric Hypersurfaces

In this section we follow mainly V. Batyrev's article [Bat].

4.1.1 Definition: Let X, Y be algebraic varieties and K_X, K_Y their canonical classes. A proper birational morphism $\varphi : Y \rightarrow X$ is called *non-discrepant* if $K_Y = \varphi^*(K_X)$.

4.1.2 Proposition: Let $\Delta \subset \mathbb{R}^d$ be a reflexive polytope, Σ its normal fan and $X_\Delta = X_\Sigma$ the corresponding toric variety. Then Σ is the fan consisting of all cones generated by proper faces of Δ^* .

Let Σ' be a subdivision of Σ and $\varphi : X_{\Sigma'} \rightarrow X_\Sigma$ the corresponding toric morphism. Then φ is non-discrepant if and only if Σ' is generated by a lattice subdivision of the boundary of Δ^* .

Proof: The first statement follows from the definition of the normal fan. For the second statement see [Bat], prop. 2.2.12. \square

Remark: Let X be a complete toric variety. The algebraic significance of the fact that $X = X_\Delta$ for a reflexive polytope Δ is that X is a Gorenstein Fano variety (meaning that the anticanonical divisor is an ample Cartier divisor).

4.1.3 Definition: We call the toric variety $X_{\Sigma'}$ a *toric smooth projective non-discrepant desingularization (toric SPC-desingularization⁴)* if the subdivision of $\partial(\Delta^*)$ is a unimodular coherent triangulation.

4.1.4 Proposition: A toric SPC-desingularization is smooth.

Proof: This is immediate. \square

4.1.5 Definition: Let $\Delta \subset \mathbb{R}^d$ be a reflexive polytope and X_Δ the associated real toric variety. Let

$$f(X_1, \dots, X_d) = \sum_{m \in \Delta} c_m X_1^{m_1} \dots X_n^{m_d}$$

be a Laurent-polynomial with Newton-polytope Δ . f defines a hypersurface in $(\mathbb{R}^*)^d$. We designate its completion in X_Δ by Z .

We call Z Δ -regular if for every $\sigma \in \Sigma$ the intersection $Z \cap O_\sigma$ is transversal or empty.

⁴where the C stands for the somewhat artificial word “crepant”, which is better suited for abbreviations than ”non-discrepant”.

4.1.6 Proposition: *The hypersurfaces Z are generically Δ -regular. In other words, the set of Laurent-polynomials defining Δ -regular hypersurfaces is Zariski-open in the set of all Laurent-polynomials.*

Proof: See [Bat], prop. 3.1.3. □

Remark: The property of being Δ -regular can be interpreted as follows: The singularities of Z are all induced by the singularities of the ambient toric variety X_Δ .

So resolving the singularities of X_Δ resolves the singularities of all Δ -regular hypersurface at the same time.

4.1.7 Definition: Let Δ be a reflexive polytope, X_Δ the corresponding toric variety and Z a Δ -regular hypersurface. Let $\varphi : \tilde{X} \rightarrow X_\Delta$ be a SPC-desingularization. Then we call $\tilde{Z} := \varphi^{-1}(Z)$ a SPC-desingularization of Z .

4.1.8 Theorem: *Let $\Delta \subset \mathbb{R}^d$ be a reflexive polytope, X_Δ the corresponding toric variety and Z a Δ -regular hypersurface in X_Δ . Then any smooth toric SPC-desingularization \tilde{Z} of Z is a Calabi-Yau variety, which we call *Calabi-Yau toric hypersurface*.*

If \tilde{Z}' is an analogously constructed variety for Δ^ and $d \geq 4$ then*

$$\begin{aligned}
 h^{1,1}(\tilde{Z}) &= h^{d-2,1}(\tilde{Z}') \\
 &= l(\Delta^*) - d - 1 - \sum_{\Theta \subset \Delta^* \text{ facet}} l^*(\Theta^*) + \sum_{\substack{\Theta^* \subset \Delta \text{ face,} \\ \text{codim } \Theta = 2}} l^*(\Theta)l^*(\Theta^*).
 \end{aligned}$$

Proof: By [Bat], theorem 4.1.9, it follows that Z fulfills all properties of being a Calabi-Yau apart from being smooth. \tilde{Z} is smooth, so we have to show that the remaining properties do not get lost in the process of the desingularization. By prop. 3.2.2 of the same article the desingularization morphism is non-discrepant on Z , so $K_{\tilde{Z}} = K_Z = 0$. By the same arguments as used in the proof of [Bat], 4.1.9 for Z one deduces that $H^i(\tilde{Z}, O_{\tilde{Z}}) = 0$ for all $i = 0 < \dots < \dim \tilde{Z}$.

The second part of the statement is theorem 4.4.3 of [Bat]. \square

Remark: The second part of the above theorem verifies the relation of Hodge numbers of a 3-dimensional mirror pair. It is to be noted that in the construction various choices can be made without affecting the validity of the theorem. Such independencies are quite typical of Calabi-Yau varieties. For instance, one might choose two different toric SPC-desingularizations. The resulting varieties are then birationally equivalent. Batyrev showed in [Bat2] that any two birational complex Calabi-Yau varieties have the same Betti numbers (Kontsevich announced in [Kon1] that this is even true for the individual Hodge numbers). So in particular, this is true for two different choices of toric SPC-desingularizations. In some of the next sections we will prove such types of results also for real Calabi-Yau varieties.

Up to the end of the section we will adopt the following notation: If Θ is a lattice polytope, then we designate by $X_{\Sigma(\Theta)}$ the real toric variety associated with the cone over Θ in the linear space generated by $\text{cone}(\Theta)$. For a unimodular coherent triangulation \mathcal{T} of Θ , we designate by $X_{\Sigma(\Theta, \mathcal{T})}$ the real local toric Calabi-Yau variety defined by \mathcal{T} and by

$$\varphi_{\Theta, \mathcal{T}} : X_{\Sigma(\Theta, \mathcal{T})} \longrightarrow X_{\Sigma(\Theta)}$$

the desingularization defined by \mathcal{T} . By

$$x_{\Theta} := O_{\text{cone}(\Theta)} \subset X_{\Sigma(\Theta)}$$

we designate the unique torus-invariant point in $X_{\Sigma(\Theta)}$.

4.1.9 Proposition: *Let Δ be a reflexive polytope and Z a real Δ -regular hypersurface in X_{Δ} . Let $\varphi : \tilde{X} \rightarrow X_{\Delta}$ be a toric SPC-desingularization of X_{Δ} , defined by a unimodular coherent triangulation \mathcal{T} of the boundary of Δ^* . For any face $\Gamma \subset \Delta$ let $Z_{\Gamma} := Z \cap O_{\text{cone}(\Gamma^*)}$.*

Then $\varphi^{-1}(Z_{\Gamma})$ is isomorphic to $Z_{\Gamma} \times \varphi_{\Gamma^, \mathcal{T}}^{-1}(x_{\Gamma^*})$.*

Proof: Let Γ be any face of Δ and $y \in O_{\text{cone}(\Gamma^*)}$ any point. According to [Bat] 4.2.5, $\varphi^{-1}(y)$ is isomorphic to $\varphi_{\Gamma^*, \mathcal{T}}^{-1}(x_{\Gamma^*})$. Since φ is a toric morphism, it commutes with the torus action, so $\varphi^{-1}(O_{\text{cone}(\Gamma^*)})$ is isomorphic to $O_{\text{cone}(\Gamma^*)} \times \varphi_{\Gamma^*, \mathcal{T}}^{-1}(x_{\Gamma^*})$ and the assertion follows at once by restriction to Z_Γ . \square

Remark: The $X_{\Sigma(\Theta, \mathcal{T})}$ are real local toric Calabi-Yau varieties, which we investigated in the previous chapter.

4.2 Real K3 Surfaces

K3 surfaces⁵ constitute a class of surfaces that are relatively easy to access without being by any means trivial. Thus they have been studied very intensively and successfully and have shown that they possess an inherent beautiful aesthetic.

In the following we give a short overview of some properties of complex K3 surfaces, then concentrate on the topology of real K3 surfaces. We present the classification of the topological types, which is known by works of Kharlamov (see [Kha]).

A good overview of K3 surfaces can be found in [Pls], additional information on real K3 surfaces in [Sil].

Examples: The following surfaces are K3 surfaces:

- a) a double cover of \mathbb{P}^2 ramified in a smooth sextic,
- b) a double cover of $\mathbb{P}^1 \times \mathbb{P}^1$ ramified in a smooth curve of bidegree $(4, 4)$,
- c) a smooth quartic surface in \mathbb{P}^3 ,
- d) a complete intersection of a quadric and a cubic in \mathbb{P}^4 .

⁵The name arose in the 50's of the last century and is said to be derived from the mathematicians Kähler, Kummer and Kodaira. Probably it was also inspired by a famous mountain in the Himalaya, whose first-time ascension was at that time subject to great public interest.

These examples are well-known. It is worth noting that a), b) and c) can also be deduced from theorem 4.1.8. This is immediate for case c), as the Newton polygon of the quartic is a 3-dimensional reflexive simplex. In the cases a) and b) let $f(z) = 0$ be the defining equation for the sextic, respectively for the curve of bidegree (4, 4). It is easy to verify that the Newton polytope of $t^2 - f(z)$ is a reflexive polytope and so by the same theorem defines a K3 surface. Note that the Newton polytope of f is itself a reflexive polytope stretched by factor 2. Indeed, the same principle works for all two-dimensional reflexive polytopes.

4.2.1 Proposition: *Let X be a complex K3 surface.*

(i)

$$\begin{aligned} H^0(X, \mathbb{Z}) &\cong H^4(X, \mathbb{Z}) \cong \mathbb{Z} \\ H^1(X, \mathbb{Z}) &\cong H^2(X, \mathbb{Z}) = 0 \\ H^2(X, \mathbb{Z}) &\cong \mathbb{Z}^{22}. \end{aligned}$$

The Hodge decomposition of $H^2(X, \mathbb{C}) \cong H^2(X, \mathbb{Z}) \otimes \mathbb{C}$ is given by $h^{0,2} = h^{2,0} = 1$, $h^{1,1} = 20$, thus giving rise to the following Hodge diamond:

$$\begin{array}{ccccc} & & & & 1 \\ & & & & 0 & 0 \\ & & & & 1 & 20 & 1 \\ & & & & 0 & 0 \\ & & & & & & 1 \end{array}$$

(ii) *The cup-product $H^2(X, \mathbb{Z}) \times H^2(X, \mathbb{Z}) \rightarrow H^4(X, \mathbb{Z}) \cong \mathbb{Z}$ is a bilinear, symmetric, non-degenerate form of signature (3, 19).*

Proof: See [Pls], exposé IV, section 0. \square

Complex K3 surfaces fulfill the following two strong topological properties:

4.2.2 Proposition: *X is a complex K3 surface if and only if it is simply connected and $K_X = 0$.*

Proof: See [Pls], exposé VI, section 1, corollaire 2. \square

4.2.3 Proposition: *All complex K3 surfaces are diffeomorphic.*

Proof: See [Pls], exposé VI, section 1, corollaire 1. \square

The last two statements are not true for real K3 surfaces. Thus K3 surfaces constitute a further example of the general rule that the topology over the complex numbers is much simpler than over the reals.

In the following we present the classification of the topological types of real K3 surfaces. A connected real topological closed surface is characterized by the cohomology of its connected components. So one part of the work for the classification consists in finding restrictions to the Betti numbers, another part in constructing all remaining possible cases.

Let $X_{\mathbb{C}}$ be the complexification of a real surface $X = X_{\mathbb{R}}$. Then the complex conjugation induces an antiholomorphic involution on $X_{\mathbb{C}}$ as well as an involution on cohomology groups, which we call S . Set

$$b_i := \dim S(H^i(X_{\mathbb{C}}, \mathbb{Z}))$$

and

$$\lambda_i := \dim \text{Fix}_S(H^i(X_{\mathbb{C}}, \mathbb{Z}))$$

for $i = 0, \dots, 4$, where $\text{Fix}_S(H^i(X_{\mathbb{C}}, \mathbb{Z}))$ denotes the fix point set of the action of S on the cohomology. The most important of these

numbers are those of middle dimension. To simplify notation we set

$$\begin{aligned} b &:= b_2, \\ \lambda &:= \lambda_2. \end{aligned}$$

Let further

$$B_i := \dim H^i(X_{\mathbb{C}}, \mathbb{Z}/2)$$

denote the Betti numbers of the complex surface.

4.2.4 Proposition: (Smith inequality) *Let $X_{\mathbb{R}}$ be any real algebraic variety and $X_{\mathbb{C}}$ its complexification. Then*

$$\sum_i \dim H^i(X_{\mathbb{R}}, \mathbb{Z}/2) \leq \sum_j \left(B_j - 2 \dim(1 + S)H^j(X_{\mathbb{C}}, \mathbb{Z}/2) \right).$$

Proof: See [Sil], chapter I. □

4.2.5 Definition: Real algebraic surfaces for which the Smith-inequality is valid with “=” instead of “ \leq ”, are called *Galois-maximal*.

4.2.6 Proposition: *Nonempty real K3 surfaces are Galois-maximal.*

Proof: See [Sil]. □

Remark: The Smith inequality is a generalization of the Harnack inequality for real curves, which states that it has at most $g + 1$ components, with g the genus of the curve. Curves with the maximal numbers of components are called *M-curves* and play an important role in the isotopy classification of curves.

4.2.7 Proposition: *Let X be a Galois-maximal real algebraic surface and λ_i, b_i defined as above. Then*

$$\sum_i \lambda_i \equiv b \pmod{2}.$$

4.2.8 Definition: A Galois-maximal algebraic real surface is called $(M - r)$ -surface if $\sum_i \lambda_i = r$.

4.2.9 Proposition: Let X be a Galois-maximal real algebraic surface.

a) If X is a M -surface, then

$$b \equiv 2h^{0,2} \pmod{8}.$$

b) If X is a $(M - 1)$ -surface, then

$$b \equiv 2h^{0,2} \pm 1 \pmod{8}.$$

c) If

$$b \equiv 2h^{0,2} \pm 3 \pmod{8},$$

then X is at most a $(M - 3)$ -surface (that is $\sum_i \lambda_i \geq 3$).

4.2.10 Proposition: Let $X_{\mathbb{R}}$ be a real K3 surface. Then

$$(i) \sum_i \dim H^i(X_{\mathbb{R}}, \mathbb{Z}/2) = 24 - 2\lambda,$$

$$(ii) \chi(X_{\mathbb{R}}) = 2b - 20.$$

Proof: See [Sil]. □

4.2.11 Corollary:

$$\dim H^0(X_{\mathbb{R}}, \mathbb{Z}/2) = \frac{2 + b - \lambda}{2}$$

$$H^1(X_{\mathbb{R}}, \mathbb{Z}/2) = 22 - \lambda - b.$$

Proof: This result follows immediately by Poincaré-duality. □

The presented restrictions allow as only values for (b, λ) those given in table 4.1. In the following we will show that the set of

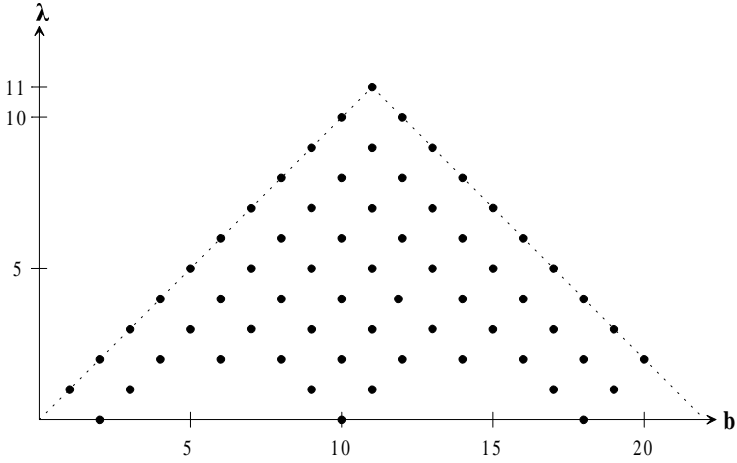

Table 4.1: Possible values of (b, λ) for a real K3 surface

restrictions is already complete and that each possible value for (b, λ) characterizes exactly one topological type of real K3 surface, with one exception. Recall also that $X_{\mathbb{R}}$ is an orientable smooth manifold. So each of its components is an orientable surface T_g of genus g . It is well-known that $\chi(T_g) = 2 - 2g$.

4.2.12 Proposition: *Let $X_{\mathbb{R}}$ be a nonempty real K3 surface. Then either $X_{\mathbb{R}} \cong T_1 \amalg T_1$ or $X_{\mathbb{R}}$ has at most one component with Euler characteristic ≤ 0 .*

Proof: See [Sil]. □

4.2.13 Corollary: *Let $X_{\mathbb{R}}$ be a nonempty real K3 surface. Then the topological type of $X_{\mathbb{R}}$ is uniquely determined up to homeomorphism by the value of (b, λ) , except when $(b, \lambda) = (10, 8)$. In this case, $X_{\mathbb{R}} \cong T_1 \amalg T_1$ and $X_{\mathbb{R}} \cong S^2 \amalg T_2$ are the possible types.*

Proof: The exceptional case is easy to verify. In the other cases $X_{\mathbb{R}} = S^2 \amalg \dots \amalg S^2 \amalg T_g$ with S^2 occurring $\frac{2+b-\lambda}{2} - 1$ times. So

$$\begin{aligned} 2b - 20 &= \chi(X_{\mathbb{R}}) = \chi(S^2) + \dots + \chi(S^2) + \chi(T_g) \\ &= b - \lambda + 2 - 2g. \end{aligned}$$

Thus

$$g = 11 - \frac{b + \lambda}{2}$$

is uniquely determined and with it the topological type of $X_{\mathbb{R}}$. \square

4.2.14 Proposition: *All real 2-folds corresponding to a value of (b, λ) in table 4.1 can be realized as a real K3 surface. The complete list of topological types is given in table 4.2 (there are 66 of them).*

Proof: In fact, all of these types can be realized as smooth quartics in $\mathbb{R}\mathbb{P}^3$ (see [Kha]) as well as as double cover of $\mathbb{R}\mathbb{P}^2_+$ ramified along a smooth real sextic curve, where $\mathbb{R}\mathbb{P}^2_+$ is the part of $\mathbb{R}\mathbb{P}^2$, where the sextic is positive. In the latter case, clearly, the topology of the K3 surface depends only on the isotopy type of the real sextic. This isotopy classification was completed by Gudkov in 1969 ([Gud]), simpler constructions were given later by O. Viro in [Vi2] by using the method we present in the next section. Table 4.3 shows the complete list (there are 55 types):

A comparison with the topological types of real K3 surfaces shows that indeed all can be realized as double cover (note that each curve leads to two different covers according to the sign of the sextic). So the theory of real K3 surfaces yields a striking connection between real smooth quartic surfaces of \mathbb{P}^3 and real smooth plane sextic curves. \square

$9S^2 \amalg T_2$	$5S^2 \amalg T_5$	$5S^2 \amalg T_6$	$S^2 \amalg T_9$	$S^2 \amalg T_{10}$
$8S^2 \amalg T_1$	$5S^2 \amalg T_3$	$4S^2 \amalg T_6$	$S^2 \amalg T_7$	$S^2 \amalg T_8$
$7S^2 \amalg T_1$	$6S^2 \amalg T_3$	$4S^2 \amalg T_4$	$2S^2 \amalg T_7$	$S^2 \amalg T_8$
$8T_0$	$5S^2 \amalg T_2$	$4S^2 \amalg T_4$	$2S^2 \amalg T_6$	T_7
$6S^2 \amalg T_1$	$4S^2 \amalg T_2$	$3S^2 \amalg T_4$	$S^2 \amalg T_5$	T_6
$7T_0$	$4S^2 \amalg T_1$	$3S^2 \amalg T_3$	$S^2 \amalg T_4$	T_5
$5S^2 \amalg T_2$	$3S^2 \amalg T_2$	$2S^2 \amalg T_3$	$S^2 \amalg T_4$	T_4
$6T_0$	$4S^2 \amalg T_1$	$2S^2 \amalg T_2$	$S^2 \amalg T_3$	T_3
$5T_0$	$3S^2 \amalg T_1$	$2S^2 \amalg T_1$	$S^2 \amalg T_2$	T_2
$4T_0$	$2S^2 \amalg T_1$	$S^2 \amalg T_1$	T_1	$T_1 \amalg T_1$
	$3T_0$	$2T_0$	T_0	\emptyset
$10T_0$				

Table 4.2: Topological types of real K3 surfaces

	$\langle 9 \Pi 1 \langle 1 \rangle \rangle$		$\langle 5 \Pi 1 \langle 5 \rangle \rangle$		$\langle 1 \Pi 1 \langle 9 \rangle \rangle$
	$\langle 10 \rangle \langle 8 \Pi 1 \langle 1 \rangle \rangle$		$\langle 5 \Pi 1 \langle 4 \rangle \rangle \langle 4 \Pi 1 \langle 5 \rangle \rangle$		$\langle 1 \Pi 1 \langle 8 \rangle \rangle \langle 1 \langle 9 \rangle \rangle$
$\langle 9 \rangle$	$\langle 7 \Pi 1 \langle 1 \rangle \rangle \langle 6 \Pi 1 \langle 2 \rangle \rangle \langle 5 \Pi 1 \langle 3 \rangle \rangle \langle 4 \Pi 1 \langle 4 \rangle \rangle \langle 3 \Pi 1 \langle 5 \rangle \rangle \langle 2 \Pi 1 \langle 6 \rangle \rangle \langle 1 \Pi 1 \langle 7 \rangle \rangle \langle 1 \langle 8 \rangle \rangle$				
	$\langle 8 \rangle \langle 6 \Pi 1 \langle 1 \rangle \rangle \langle 5 \Pi 1 \langle 2 \rangle \rangle \langle 4 \Pi 1 \langle 3 \rangle \rangle \langle 3 \Pi 1 \langle 4 \rangle \rangle \langle 2 \Pi 1 \langle 5 \rangle \rangle \langle 1 \Pi 1 \langle 6 \rangle \rangle \langle 1 \langle 7 \rangle \rangle$				
	$\langle 7 \rangle \langle 5 \Pi 1 \langle 1 \rangle \rangle \langle 4 \Pi 1 \langle 2 \rangle \rangle \langle 3 \Pi 1 \langle 3 \rangle \rangle \langle 2 \Pi 1 \langle 4 \rangle \rangle \langle 1 \Pi 1 \langle 5 \rangle \rangle \langle 1 \langle 6 \rangle \rangle$				
	$\langle 6 \rangle \langle 4 \Pi 1 \langle 1 \rangle \rangle \langle 3 \Pi 1 \langle 2 \rangle \rangle \langle 2 \Pi 1 \langle 3 \rangle \rangle \langle 1 \Pi 1 \langle 4 \rangle \rangle \langle 1 \langle 5 \rangle \rangle$				
	$\langle 5 \rangle \langle 3 \Pi 1 \langle 1 \rangle \rangle \langle 2 \Pi 1 \langle 2 \rangle \rangle \langle 1 \Pi 1 \langle 3 \rangle \rangle \langle 1 \langle 4 \rangle \rangle$				
	$\langle 4 \rangle \langle 2 \Pi 1 \langle 1 \rangle \rangle \langle 1 \Pi 1 \langle 2 \rangle \rangle \langle 1 \langle 3 \rangle \rangle$				
	$\langle 3 \rangle \langle 1 \Pi 1 \langle 1 \rangle \rangle \langle 1 \langle 2 \rangle \rangle$			$\langle 1 \langle 1 \langle 1 \rangle \rangle \rangle$	
	$\langle 2 \rangle \langle 1 \langle 1 \rangle \rangle$				
	$\langle 1 \rangle$				
	$\langle 0 \rangle$				

Table 4.3: Isotopy types of smooth real plane projective algebraic curves of degree 6.

4.3 The Patchworking Method of Viro

In his famous 16th problem of the list issued in 1900 Hilbert asked about the mutual position of the ovals of nonsingular real plane projective algebraic curves with a given degree (in modern words, the isotopy classification). Up to the 80's of the 20th century there was mainly only one method of producing examples of such curves: slight deformations of reduced singular curves (e.g. the union of two ellipses, for curves of degree 4) by small disturbances of the coefficients. But the result of this desingularization was in some way a matter of good or bad luck, which led to long and inefficient searches of the right constructions.

In 1979 O. Viro introduced a more effective method, which gives much more control on the topology (see [Vi1]). It makes it possible to build an algebraic curve by putting several pieces of other algebraic curves together (where the pieces have to fulfill some compatibility condition).

The method generalizes naturally to real hypersurfaces of toric varieties of arbitrary dimension. Still, it was probably most successfully used for the construction of real curves: Viro himself concluded the isotopy classification of real plane projective curves of degree 7 and advanced a lot in degree 8 (see [Vi2]). As another example, in 1996 I. Itenberg disproved a longstanding conjecture of Ragsdale (see [ItVi]). Itenberg used a special variant of the Viro method, the *combinatorial patchworking*, which will also serve us in our work. In this case, the patches are pieces of hyperplanes in a toric variety assigned to a lattice simplex. The hyperplanes and their glueing is determined by a sign function on the vertices of the simplex.

4.3.1 General Patchworking

4.3.1 Definition: Let

$$f = \sum_{\omega \in \mathbb{Z}^d} a_{\omega} x_1^{\omega_1} \dots x_d^{\omega_d}$$

be a real polynomial in d variables. Then the polytope $\Delta(f) := \text{Conv}\{\omega \in \mathbb{Z}^d \mid a_\omega \neq 0\}$ is called the *Newton polytope* of f .

If $\Gamma \subset \mathbb{R}^d$ is any set, we call

$$f^\Gamma := \sum_{\omega \in \mathbb{Z}^d \cap \Gamma} a_\omega x_1^{\omega_1} \dots x_d^{\omega_d}$$

the Γ -truncation of f . f is called *completely non-degenerate* if for all faces Γ of Δ , f^Γ is non-singular in $(\mathbb{R}^*)^d$.

Assume now that $\Delta = \Delta(f)$ is d -dimensional. The equation $f = 0$ defines a hypersurface in $(\mathbb{R}^*)^d$. Let Z_f denote the completion in the real toric variety X_Δ assigned to Δ .

We know that X_Δ can be obtained by glueing of copies $\Delta^{(\xi)}$, $\xi \in \{\pm 1\}^d$, along the facets. For any $\xi \in \{\pm 1\}^d$ let

$$\mu_\Delta^{(\xi)} : \xi \cdot X_\Delta^+ \rightarrow \Delta^{(\xi)}$$

be the associated moment map.

4.3.2 Definition: A *chart* of f is the set of pairs $\left\{ \left(\Delta^{(\xi)}, \mu_\Delta^{(\xi)}(Z_f) \right) \mid \xi \in \{\pm 1\}^d \right\}$, defined up to homeomorphisms of $\Delta^{(\xi)}$ preserving the faces.

4.3.3 Theorem: Let f_1, \dots, f_r be completely non-degenerated real polynomials with the following properties:

- (i) $f_i^{\Delta(f_i) \cap \Delta(f_j)} = f_j^{\Delta(f_i) \cap \Delta(f_j)}$ for all $i, j = 1, \dots, r$,
- (ii) $\Delta := \bigcup_i \Delta(f_i)$ is a convex polytope and the $\{\Delta(f_i)\}$ form a polytopal subdivision,
- (iii) the subdivision is coherent, that is, there is a convex piecewise linear function $\nu : \Delta \rightarrow \mathbb{R}$ such that the $\Delta(f_i)$, $i = 1, \dots, r$, are exactly the domains of linearity.

Let $(g_t)_t$ be a family of polynomials defined by

$$g_t = \sum_{\omega \in \mathbb{Z}^d} a_\omega t^{\nu(\omega)} x_1^{\omega_1} \dots x_d^{\omega_d},$$

with parameter $t > 0$, where a_ω is the coefficient of the same monomial of f_i , when $\omega \in \Delta_i$ (note that this is well-defined by i).

Then there is a $t_0 > 0$ such that for all $t \in [0, t_0]$, g_t is completely non-degenerate and its chart is obtained by glueing of the charts of f_1, \dots, f_r (where by the latter we understand the set $\{(\bigcup_i \Delta^{(\xi)}, \bigcup_i \mu_{\Delta_i}^{(\xi)}(Z_{f_i}))\}$).

Sketch of proof: (A more detailed sketch can be found in [IMS], see [Vi1] for the full proof.)

As the strongly convex piecewise linear functions form an open cone, we can assume that $\nu(\Delta \cap \mathbb{Z}^d) \subset \mathbb{Z}$.

Now consider the following polytope

$$\tilde{\Delta} := \{(x, y) \mid x \in \mathbb{R}, \nu(x) \leq y \leq M\},$$

where M is an arbitrary upper bound to $\nu|_{\tilde{\Delta}}$. By strong convexity of ν , $\tilde{\Delta}$ has “lower facets” $\tilde{\Delta}_1, \dots, \tilde{\Delta}_r$, where $\tilde{\Delta}_i := \{(x, \nu(x)) \mid x \in \Delta_i\}$, and an upper facet (Δ, M) .

For each $c > 0$, the equation $t - c = 0$ defines a hyperplane H_c isomorphic to $X_{(\Delta, M)} \cong X_\Delta$. For $c \rightarrow 0$, H_c degenerates to $\bigcup_i X_{\tilde{\Delta}_i} \subset X_{\tilde{\Delta}}$.

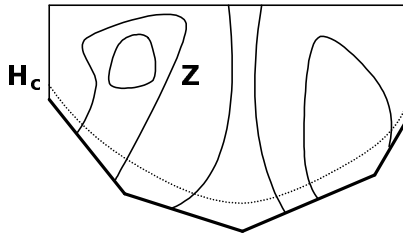

Figure 4.27: $\tilde{\Delta}$ as part of $X_{\tilde{\Delta}}$ with the hypersurfaces Z and H_c

If we interpret $(g_t)_t$ as polynomial in $d + 1$ variables, then $\{g_t = 0\}$ defines a hypersurface Z in $X_{\tilde{\Delta}}$. This hypersurface crosses H_c

transversally for all $c > 0$, as well as $\bigcup_i X_{\tilde{\Delta}_i}$. In particular, for $c > 0$ small enough,

$$Z \cap H_c \cong Z \cap \bigcup_i X_{\tilde{\Delta}_i}.$$

But $Z \cap X_{\tilde{\Delta}_i} = \{g_i^{\tilde{\Delta}_i} = 0\} \subset X_{\tilde{\Delta}_i}$. The isomorphism $X_{\tilde{\Delta}_i} \rightarrow X_{\Delta_i}$ given by the projection $\tilde{\Delta}_i \rightarrow \Delta_i$ takes this to $\{f_i = 0\} \subset X_{\Delta_i}$. So the chart of $Z \cap H_c$ is obtained by patchworking the charts of f_1, \dots, f_r . \square

Example: Let $f(x, y) = y^2 + x^2(x - 1)$, $g_1(x, y) = y^2 - x^2 + 1$, $g_2(x, y) = y^2 - x^2 - 1$. The charts of f, g_1 and g_2 can be seen in figures 4.28-4.30. By patchworking with g_1 or with g_2 we get two topologically different results, which are shown in figures 4.31 and 4.32.

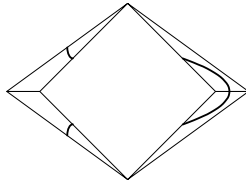

Figure 4.28: The chart of f

4.3.2 Combinatorial Patchworking

Let $\Delta \subset \mathbb{R}^d$ be a d -dimensional bounded lattice polytope with a coherent lattice triangulation \mathcal{T} . Let to every vertex of the triangulation be assigned a sign, or in other words, let a function

$$\varepsilon : \mathcal{T}(0) \rightarrow \{\pm 1\}$$

be given. For every $\xi \in \mathbb{S} := \text{Hom}(\mathbb{Z}^d, \{\pm 1\})$ let $\Delta^{(\xi)}$ be a copy of Δ and $\mathcal{T}^{(\xi)}$ a copy of the triangulation. We set the signs on the copies

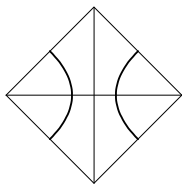

Figure 4.29: The chart of g_1

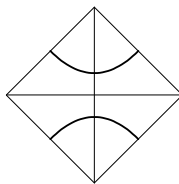

Figure 4.30: The chart of g_2

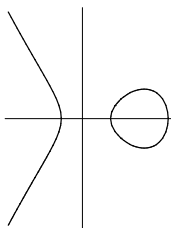

Figure 4.31: The result of patchworking from f and g_1

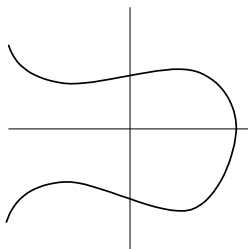

Figure 4.32: The result of patchworking from f and g_2

of the vertices as follows:

$$\begin{aligned} \varepsilon^{(\xi)} : \mathcal{T}^{(\xi)}(0) &\rightarrow \{\pm 1\} \\ v^{(\xi)} &\mapsto \xi^v \cdot \varepsilon(v), \end{aligned}$$

where we write ξ^v for the value of v under the map ξ .

We make the following recursive construction:

(i) For all $\sigma \in \mathcal{T}(1)$, for all $\xi \in \mathbb{S}$:

$$Z_{\sigma^{(\xi)}} := \begin{cases} \hat{\sigma}^{(\xi)}, & \text{if the vertices of } \sigma^{(\xi)} \text{ have different sign,} \\ \emptyset, & \text{if both vertices of } \sigma^{(\xi)} \text{ have the same sign.} \end{cases}$$

We recall that $\hat{\sigma}$ is the barycenter of σ .

(ii) For $\dim \sigma = i > 1$ let τ_0, \dots, τ_i be the facets of σ . Then for all $\xi \in \mathbb{S}$ we define

$$Z_{\sigma^{(\xi)}} := \text{conv}\left(\bigcup_{k=0}^i Z_{\tau_k^{(\xi)}}\right),$$

which is an $(i - 1)$ -cell (this is easy to verify on a standard simplex $\sigma = \{x \mid \sum x_i = 1\}$, where $Z = \{x \in \sigma \mid \sum_I x_i = \frac{1}{2}\}$ and I is the set of indices with positive sign).

Then $Z_{\sigma^{(\xi)}}$ is a cell that divides the vertices of $\sigma^{(\xi)}$ with positive sign from those with negative sign, or is empty if all signs are equal.

We define the following equivalence relation on $\Delta^{(\bullet)} := \bigcup_{\xi} \Delta^{(\xi)}$: For every face Γ of Δ we identify $\Gamma^{(\xi)}$ with $\Gamma^{(\xi')}$ if and only if $\xi \cdot \xi'$ is constant on $\text{Aff}(\Gamma) \cap \mathbb{Z}^d$ (or equivalently $\xi \cdot \xi^{-1} \equiv 1$ on $\text{Latt}(\Gamma)$). We define

$$X_{\Delta} := \bigcup_{\xi \in \mathbb{S}} \Delta^{(\xi)} / \sim$$

$$Z := \bigcup_{\sigma \in \mathcal{T}, \xi \in \mathbb{S}} Z_{\sigma^{(\xi)}} / \sim$$

and $\mathcal{T}_{X_{\Delta}}$ to be the induced triangulation on X_{Δ} .

Recall that X_{Δ} is homeomorphic to the real toric variety assigned to Δ (and thus we denote it in the same way).

4.3.4 Proposition: *Z is isotopic to a hypersurface in X_{Δ} , that means there exists a hypersurface $Y \subset X_{\Delta}$ and a homeomorphism*

$\Phi : X_\Delta \rightarrow X_\Delta$, such that $\Phi(Z) = Y$. On $(\mathbb{R}^*)^d \subset X_\Delta$ the hypersurface can be defined as the zero-set of a real polynomial with Newton polygon Δ .

Proof: By the general patchworking theorem, it is enough to show that for any $\sigma \in \mathcal{T}(d)$ there are a polynomial f and homeomorphisms $\Phi^{(\xi)} : \sigma^{(\xi)} \rightarrow \sigma^{(\xi)}$ for all $\xi \in \mathbb{S}$ that preserve the faces and map $Z_{\sigma^{(\xi)}}$ to the chart of f .

Let v_0, \dots, v_d be the vertices of σ and set

$$f(x) := \sum_i \varepsilon(v_i) x^{v_i}.$$

In the following we will assume $\xi = (1, \dots, 1)$, the other cases are easy to deduce.

Let $\tilde{\sigma}$ be the d -dimensional standard simplex. An affine map $\sigma \rightarrow \tilde{\sigma}$ defines a rational map $X_\sigma \rightarrow X_{\tilde{\sigma}}$ that induces a diffeomorphism $X_\sigma^+ \rightarrow X_{\tilde{\sigma}}^+$. By the moment map, we can view this as a diffeomorphism $\sigma \rightarrow \tilde{\sigma}$ preserving the faces. The induced signs on the vertices of $\tilde{\sigma}$ define as above a polynomial \tilde{f} and Z_σ is mapped to the hypersurface $\tilde{Z} \subset X_{\tilde{\sigma}}$ defined by \tilde{f} . But \tilde{Z} is a hyperplane, and it is easy to see that it indeed separates the signs on the vertices of $\tilde{\sigma}$, and so the same must be true for Z and the signs on the vertices of σ . \square

Examples: We show some examples that demonstrate how this method can be used to construct topological models of real K3 surfaces.

Let Δ be a 2-dimensional polytope that arises from a reflexive polytope by doubling the length of the edges. Let Z be a hypersurface of X_Δ , defined by a real polynomial f with Newton polygon Δ . Then Z divides X_Δ into two parts: X_Δ^+ and X_Δ^- according to the (well-defined) sign of f (note that we can interchange the role of the two parts by multiplying f with -1).

The double cover of X_Δ^+ branched along Z is a real K3 surface (as its complexification is the double cover of X_Δ branched along Z , which is a complex K3 surface).

In the following examples (figures 4.33 and 4.34), Δ is either the triangle $(0, 0), (6, 0), (0, 6)$ leading to a curve of degree 6 in \mathbb{RP}^2 , or the square with vertices $(0, 0), (4, 0), (0, 4), (4, 4)$ leading to a curve of bidegree $(4, 4)$ in $\mathbb{RP}^1 \times \mathbb{RP}^1$. The hypersurface Z is obtained by combinatorial patchworking.

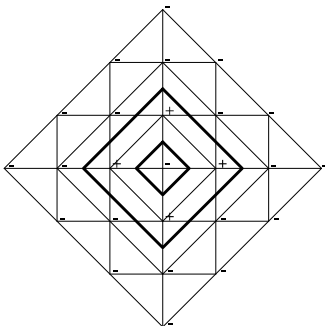

Figure 4.33: The double cover of X_{Δ}^{+} gives rise to an oriented surface of genus 1. The double cover of X_{Δ}^{-} gives rise to an oriented surface of genus 1 and a sphere.

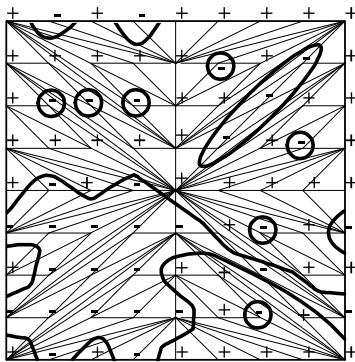

Figure 4.34: The double cover of X_{Δ}^{+} gives rise to an oriented surface of genus 9. The double cover of X_{Δ}^{-} gives rise to an oriented surface of genus 1 and 8 spheres.

4.4 Algorithms and Implementations

The combinatorial patchworking method seems at a first glance ideally suited for performing calculations with a computer: The method itself consists of relatively few, explicit steps which have to be repeated boringly often, the input data are very concrete, it is reasonably easy to get them into machine-readable form and the output data describe the hypersurface and its ambient space as cell complexes, which are very useful for further calculations.

Nevertheless, to our knowledge such a program has never been realized before. A possible explanation may be that so far the main application of the method has been the construction of curves. What would be a desirable task, however, namely making the computer check all curves of a given degree that can be constructed via combinatorial patchworking, fails completely in practice due to the huge number of possible choices. So the interesting examples still have to be constructed by an “intelligent and inspired brain” by carefully building triangulations and selecting signs. But then, the topological type of the curve is already apparent from the work with paper and pen and the computer is of no additional use.

For our purpose, which lies in the construction of Calabi Yau varieties, the situation is much more favorable: In higher dimensions (typically 2 or 3) paper and pen constructions get more and more difficult if not impossible, even in very simple cases. Furthermore, it becomes much more necessary to describe the varieties by some numerical invariants than to have their actual picture.

These considerations led us to implement an algorithm for the calculation of the homology groups of a hypersurface constructed by combinatorial patchworking. The program was realized with Maple. Excessive duration of the calculation is always an imminent danger in this kind of problems, but fortunately we found that the examples we are interested in lie within the range of computability. We sometimes encountered crashes due to memory exhaustion, but this is mainly due to inefficient use of the available resources (see below for a more detailed discussion of these issues). In order to push the

limit a little further at least for partial results we also wrote a procedure that just computes the number of connected components and is considerably faster.

The Algorithms

As the general outline of the two programs should already be clear from the description of the combinatorial patchworking method and great parts of them deal with mathematically uninteresting implementation details, we give here only a rough overview of the algorithm, highlighting just one aspect of orientations which has not been discussed yet. For those who are interested in details, we refer to the source code and its comments (see [VHH], the relevant procedures are named “HS_Homology” and “HS_NrOfComp”).

We further note that the programs rely on the package “convex” by Matthias Franz, which can be downloaded at [Frz2].

A HS_Homology

The program divides in the following steps:

- 0: Check the correctness of the given triangulation
(this step is not really necessary but quite useful in practice).
- I: Determine the full triangulation \mathcal{T}
(input data are only the maximal simplices)
- II: Calculate the glueing:
 - Determine Δ and all its faces (with package “convex”)
 - For each face Γ of Δ :
 - Calculate a basis of $\text{Aff}(\Gamma)$ (with package “convex”)
 - Calculate a lattice basis of $\text{Aff}(\Gamma) \cap \mathbb{Z}^d$
(this is done by implementing an algorithm by J. Hobby, see [Hob])

- For each $\xi \in \text{Hom}(\mathbb{Z}^d, \{\pm 1\})$:
 - * Check: Is ξ constant on the basis?
 - Yes \rightarrow add ξ to the set U_Γ

III: Construct the list of the cells of the hypersurface:

- For all simplices σ :
 - Set $G = \text{Hom}(\mathbb{Z}^d, \{\pm 1\})$
 - (L): Take $\xi \in G$
 - Check: Is $\varepsilon^{(\xi)}|_\sigma$ constant?
 - Yes \rightarrow Substitute G by $G \setminus \{\xi\}$, go to (L)
 - No \rightarrow
 - * Determine minimal face Γ of Δ , such that $\sigma \subset \Gamma$
 - * Add (σ, U_Γ) to the list of cells
 - * Replace G by $G \setminus U_\Gamma$, go to (L)

IV: Construct the boundary matrices:

- For all cells $C = (\sigma, U)$:
 - Set v_0, \dots, v_k to be the the vertices of σ (in the order in which $\mathcal{T}(0)$ is stored)
 - Reverse the signs of the vertices if v_0 has negative sign
 - Set i_0, \dots, i_α to be the indices of the vertices with positive sign
 - Set j_0, \dots, j_β to be the indices of the vertices with negative sign
 - For all $m = 0, \dots, k$:
 - * Let σ' be the simplex spanned by $v_0, \dots, \widehat{v_m}, \dots, v_k$
 - * Let $C' := (\sigma', U')$ be the (unique) cell such that $U \subset U'$

- * If $m = 0$ and v_1 has negative sign $\longrightarrow BM_{C,C'}^{(k)} := (-1)^{\alpha\beta}$
- * In the other cases if v_m has positive sign and $m = i_s \longrightarrow BM_{C,C'}^{(k)} := (-1)^{\beta+s}$
- * If v_m has negative sign and $m = j_t \longrightarrow BM_{C,C'}^{(k)} := (-1)^t$

- All other entries of the matrices $BM^{(1)}, \dots, BM^{(d-1)}$ are set to 0

(For an explanation of this part, see the discussion below)

V: Compute the homology groups:

- Calculate the Smith normal form of $BM^{(1)}, \dots, BM^{(d-1)}$ (integer coefficient case)
- Calculate the rank of $BM^{(1)}, \dots, BM^{(d-1)} \pmod p$ ($\pmod p$ coefficient case)
(both are done with Maple built-in procedures)
- Interpret the results in terms of homology groups

B HS_NrOfComp

Steps I-III are identical. It is enough, though, to consider cells of dimension 0 and 1 (or maximal and codimensional 1 cells if the hypersurface is known to be smooth).

IV: Determine the number of components:

- For each 1-cell (σ, U) : (the smooth case is completely analogous)

- Check: Is $(\partial\sigma, U)$ contained in the boundary of some component in the current list?
 - No \rightarrow Add the new component $\{(\sigma, U)\}$ to the list
 - Yes \rightarrow Remove all such components C_1, \dots, C_r and add a new component $\bigcup_{i=1}^r C_i \cup \{(\sigma, U)\}$

On the Orientation of the Cells

We begin with a reformulation of some well-known statements.

4.4.1 Definition: Let V be a real vector space and $P \subset V$ a full-dimensional polyhedron. An *orientation* on P is an ordered basis of V (if P is not full-dimensional then consider $P - x_0$ and the linear space spanned by it for some $x_0 \in P$). Two orientations are said to *lie in the same orientation class* if their transition matrices have positive determinant.

Let F be a facet of P and \vec{n} an outer normal vector of F . Let (e_1, \dots, e_d) be an orientation on P . Let (e'_1, \dots, e'_d) be the orientation obtained from the previous one by a rotation such that:

- (i) e'_k is the image of e_k for $k = 1 \dots d$,
- (ii) $e'_1 = \alpha \vec{n}$ for some $\alpha > 0$,
- (iii) (e'_2, \dots, e'_d) is an orientation on F .

Then (e'_2, \dots, e'_d) is called the *induced (by the orientation on P) orientation on F* .

For our purposes it is quite useful to reformulate these definitions in terms of simplices:

4.4.2 Proposition: *The following definitions are equivalent to the above ones:*

An orientation on P is an ordered simplex σ in the affine hull of P , defined up to translation (ordered meaning that the vertices of σ are ordered). Two orientations lie in the same orientation class

if they are mapped to each other by a bijective affine linear map whose linear part has positive determinant (i.e. $\tilde{\sigma} = v_0 + A\sigma$ where $\det A > 0$).

Let F be a facet of P and $\sigma = [v_0 \dots v_d]$ an orientation on P . Let \tilde{F} be the affine hull of F and \tilde{P} be the half-space having the boundary \tilde{F} and containing P . Let $\sigma' = [v'_0 \dots v'_d]$ be the image of σ under an affine linear bijection with linear part having positive determinant such that:

- (i) v'_k is the image of v_k for $k = 0, \dots, d$,
- (ii) v'_0 lies in the relative interior of \tilde{P} ,
- (iii) $[v'_1, \dots, v'_d]$ is an orientation on F .

Then $[v'_1, \dots, v'_d]$ is the induced (by σ) orientation on F .

Proof: This is a straightforward reformulation of the previous definitions when setting $e_i := v_i - v_0$. \square

4.4.3 Proposition: Let $\sigma = [v_0 \dots v_d]$ and $\sigma' = [v_{\pi(0)} \dots v_{\pi(d)}]$ be simplices with the same vertices, but in a different order. Then σ and σ' lie in the same orientation class if and only if $\text{sign}(\pi) = 1$. Identifying the two possible classes with $+1$ and -1 we have

$$\bar{\sigma}' = (-1)^{\text{sign}(\pi)} \bar{\sigma}$$

(where the bars indicate the corresponding classes).

Proof: The map $\sigma \mapsto \sigma'$ is given by a permutation matrix, which has determinant 1 if and only if the permutation has signum 1, hence the assertion. \square

4.4.4 Corollary: Let $\sigma = [v_0 \dots v_d]$ be a simplex and designate by $\tau_i := [v_0 \dots \hat{v}_i \dots v_d]$ the i -th face of σ . Then the induced (by σ) orientation class on τ_i is $(-1)^i \bar{\tau}_i$.

Proof: The assertion is easy to verify for $i = 0$. For $i > 0$ replace first σ by $\sigma' := [v_i v_0 \dots \widehat{v}_i \dots v_d]$. The corresponding index permutation is the cycle $(0..i)$, hence $\bar{\sigma}' = (-1)^i \bar{\sigma}$ by the proposition. \square

Let K be a cell complex and for each $\sigma \in K$ let $o(\sigma)$ be an orientation on σ . Then the corresponding (integral) chain complex C_\bullet consists of abelian groups

$$C_i := \left\{ \sum_{\text{finite}} a_j \sigma_j \mid \sigma_j \in K, \dim \sigma_j = i, a_j \in \mathbb{Z} \right\}$$

with boundary maps $\partial : C_i \rightarrow C_{i-1}$, defined by

$$\partial \sigma = \sum_{\tau \text{ facet of } \sigma} \varepsilon_\tau \tau,$$

where

$$\varepsilon_\tau = \begin{cases} 1, & o(\tau) \text{ and the orientation on } \tau \text{ induced by } \sigma \\ & \text{lie in the same class,} \\ -1, & \text{else.} \end{cases}$$

4.4.5 Theorem: Let Δ be a lattice polytope, \mathcal{T} a lattice triangulation of it, $\varepsilon : \mathcal{T}(0) \rightarrow \{\pm 1\}$ a sign function on the vertices and let any ordering on $\mathcal{T}(0)$ be given.

Let $Z \subset X_\Delta$ be the hypersurface constructed by combinatorial patchworking and C_\bullet the integral chain complex corresponding to the cell decomposition of Z induced by \mathcal{T} , so

$$C_i := \left\{ \sum_{\text{finite}} a_{\sigma(\varepsilon)} Z_{\sigma(\varepsilon)} \mid \sigma(\varepsilon) \in \mathcal{T}_{X_\Delta} \text{ non-empty, } \dim \sigma = i+1, a_{\sigma(\varepsilon)} \in \mathbb{Z} \right\}.$$

Then a “valid” boundary map (i.e. generated by a choice of orientation on the $Z_{\sigma(\varepsilon)}$) is defined by the following:

$$\partial Z_{\sigma(\varepsilon)} := \sum_{\substack{\tau \text{ facet of } \sigma, \\ \varepsilon^{(\varepsilon)}|_\tau \text{ non-constant}}} \delta_{\tau(\varepsilon)} Z_{\tau(\varepsilon)},$$

where $\delta_{\tau(\varepsilon)}$ is determined as follows:

With $\sigma = [v_0 \dots v_d]$ (in the given order) let $0 = i_0 < i_1 < \dots < i_\alpha$ designate the indices such that $\varepsilon^{(\varepsilon)}(v_{i_k}) = \varepsilon^{(\varepsilon)}(v_0)$ for all $k = 0, \dots, \alpha$ and $j_0 < j_1 < \dots < j_\beta$ the other indices. In this notation

$$\delta_{\tau(\varepsilon)} := \begin{cases} (-1)^l, & \sigma(0) \setminus \tau(0) = \{v_{j_l}\}, \\ (-1)^{\alpha\beta}, & \sigma(0) \setminus \tau(0) = \{v_0\} \text{ and } \varepsilon^{(\varepsilon)}(v_1) \neq \varepsilon^{(\varepsilon)}(v_0), \\ (-1)^{\beta+k}, & \text{else.} \end{cases}$$

Proof: Let $\sigma = [v_0 \dots v_d] \in \mathcal{T}, \xi \in \text{Hom}(\mathbb{Z}^d, \{\pm 1\})$. Without loss of generality we may assume that $\xi = \text{id}$. We further assume that σ is non-empty, that is, not all vertices have the same sign, and that $\varepsilon(v_0) = 1$ (note that the latter assumption makes the sign function well-defined, no matter which glueing-equivalent copy of σ we consider). To simplify the notation we will write v_k instead of v_{i_k} and w_l instead of w_{j_l} from now on.

Then we choose the following simplex as orientation on Z_σ :

$$o(Z_\sigma) := \left[[v_0 w_0][v_0 w_1] \dots [v_0 w_\beta] \right. \\ \left. [v_1 w_0] \dots [v_\alpha w_0] \right].$$

This is indeed an orientation in the sense of proposition 4.4.2, i.e. a full-dimensional simplex in $\text{Aff}(Z_\sigma)$, as the edges of $o(Z_\sigma)$ containing $[v_0 w_0]$ are exactly the edges of Z_σ containing $[v_0 w_0]$ (to verify this, note that both are equal to the set $\{[v_0 v_k w_0] \mid 1 \leq k \leq \alpha\} \cup \{[v_0 w_0 w_l] \mid 1 \leq l \leq \beta\}$).

Now let τ be a non-empty facet of σ . Then $\tau = [v_0 \dots \widehat{v_k} \dots v_\alpha \dots]$ or $\tau = [\dots w_0 \dots \widehat{w_l} \dots w_\beta \dots]$. We distinguish the following cases:

(i) $1 \leq k \leq \alpha$ or $1 \leq l \leq \beta$: Then

$$o(Z_\tau) = \left[[v_0 w_0][v_0 w_1] \dots [v_0 w_\beta] \right. \\ \left. [v_1 w_0] \dots [\widehat{v_k w_0}] \dots [v_\alpha w_0] \right]$$

resp.

$$o(Z_\tau) = \left[[v_0 w_0][v_0 w_1] \dots \widehat{[v_0 w_l]} \dots [v_0 w_\beta] \right. \\ \left. [v_1 w_0] \dots [v_\alpha w_0] \right].$$

So, $o(Z_\tau)$ is the $(\beta + k)$ -th resp. the l -th face of $o(Z_\sigma)$, hence by corollary 4.4.4 the induced orientation is in the same class as $o(Z_\tau)$ if and only if $(\beta + k) \equiv 0 \pmod{2}$ resp. $l \equiv 0 \pmod{2}$.

(ii) $l = 0$: Then

$$o(Z_\tau) = \left[[v_0 w_1][v_0 w_2] \dots [v_0 w_\beta] \right. \\ \left. [v_1 w_1] \dots [v_\alpha w_1] \right].$$

Now we interchange the role of w_0 and w_1 : As the vertices of σ (without v_0) form a basis for $\text{Aff}(\sigma) - v_0$, this is realized by an orientation-reversing map (given by $w_1 \mapsto w_0, w_0 \mapsto w_1$). The image of Z_σ is clearly Z_σ itself as set, but as the orientation is reversed we write $-Z_\sigma$ for it. Then

$$o(-Z_\sigma) = \left[[v_0 w_1][v_0 w_0] \dots [v_0 w_\beta] \right. \\ \left. [v_1 w_1] \dots [v_\alpha w_1] \right]. \quad (*)$$

So $o(Z_\tau)$ is the first facet of $o(-Z_\sigma)$ (beginning to count with 0), so

$$o(Z_\tau) = -o(-Z_\sigma) = o(Z_\sigma).$$

(iii) $k = 0$: In the case that $\varepsilon(v_1) = 1$, an argument analogous to that used in (ii) shows that $o(Z_\tau) = (-1)^\beta o(Z_\sigma)$. If $\varepsilon(v_1) = -1$, then to fit in the line of the previous arguments, we have to replace ε by $-\varepsilon$, thus interchanging the role of the v_k and the w_l . So,

$$o(Z_\tau) = \left[[w_0 v_1][w_0 v_2] \dots [w_0 v_\alpha] \right. \\ \left. [w_1 v_2] \dots [w_\beta v_2] \right].$$

Changing the ordering of the vertices in $o(Z_\tau)$ and writing $v_k w_l$ instead of $w_l v_k$ we get

$$o(Z_\tau) = \lambda \left[[v_1 w_0][v_2 w_1] \dots [v_2 w_\beta] \right. \\ \left. [v_2 w_0] \dots [v_\alpha w_0] \right]. \quad (*)$$

The change of the ordering can be effectuated in the following way: First move $[v_\alpha w_0]$ to the end by a series of β transpositions. Then move $[v_{\alpha-1} w_0]$ to the end right before $[v_\alpha w_0]$. This also needs β transpositions. Then go on in the same way up to $[v_2 w_0]$. Altogether we need $\alpha - 1$ times β transpositions, so $\lambda = (-1)^{(\alpha-1)\beta}$. Now, (*) without the factor λ is exactly the same as if $\varepsilon(v_1)$ had been positive. By applying the previous results, we conclude that

$$o(\tau) = (-1)^{(\alpha-1)\beta+\beta} = (-1)^{\alpha\beta}.$$

□

Runtime issues

Time and memory consumption are major issues for the practical application of the algorithm. Both tend to explode with increasing dimension and number of simplices. As this is a problem-inherent behaviour and thus cannot be effectively overcome, any project of experiments starts with the doubt whether any interesting examples can be calculated at all. Fortunately, for our purpose and in the actual implementation and today's (2010) personal computer abilities, this is just about the case: The calculation time for the examples in section 4.6 ranged from about one minute for the smallest ones up to an indefinite time for the largest, when Maple crashed due to memory problems (on one of our machines Maple does not seem to

work with matrices much larger than 4000×4000 ⁶, although the installed memory should be sufficient to contain them, on another machine this problem did not occur, but the installed memory was not enough, which caused poor performance because of the memory swapping).

We tried to make the program as fast as possible within the chosen setting (unfortunately making the code much less legible). Nevertheless, there is still plenty of room for improvements of the efficiency:

First of all, Maple is not really well-suited for time-critical calculations. It's the price to pay for its "mathematical understanding", exact arithmetic, large functionality available under a single surface, automatic memory handling etc. An implementation of the same algorithm in a lower-level language such as C/C++ or similar, should speed up things considerably, but would also cost considerably more effort for the development.

Runtime analysis of the different parts of the program shows that by far the most time-consuming step (> 95%) is the calculation of the Smith normal form of the boundary matrices (with integer coefficients; with mod p coefficients this step is effectuated a lot faster. Unfortunately the Maple routines appeared to produce wrong results). There exist much more efficient algorithms for that problem than those built in in Maple, especially for sparse matrices which we have here (see e.g. [Gbr] or [DSV]). The latter authors claim (in 2001) that they successfully worked with sparse matrices having about 10^5 rows and columns. However, these algorithms have two small drawbacks also: One is that they are probabilistic algorithms. So, it might happen, though highly improbable, that the result is wrong. The other is that they do not calculate the transformation matrices. This would not be a problem in our program as we do not need them. But in further applications they might be useful.

⁶More precisely, the maximal size depends on the type of the matrix: working with bounded integers instead of unlimited ones, or declaring the matrices as sparse allows bigger matrices. Unfortunately the Maple procedure that computes the Smith normal form seems to use internally only the most general matrices.

A further source of speed-up (and much in the trend of today's time) could be provided by parallelization. Indeed, most operations in the loops of each single step I-V are independent. Parallel programming functionality is even provided in newer versions of Maple (in order to make full use of the power of multi-core processors), but is not recommended yet by the developers because it has not been sufficiently tested.

Future Versions

The implemented version of the algorithm was conceived as a starting point for further development. Indeed, there are many ideas to improve the program and enlarge its functionality:

On one hand, as has become clear from the discussion above, an implementation in a low-level programming language using fast algorithms for the computation of the Smith normal form, would be very desirable.

On the other hand, additional features could include:

- Calculate the image of a cycle in the homology groups (this requires the knowledge of the transformation matrices and thus seems not to be possible using the probabilistic algorithms for the Smith normal form).
- Relative Homology
- Homology of $\overline{Z \setminus A}$, where A is a subcomplex.
- Homology of a desingularization of the hypersurface.

4.5 Euler Characteristic and Betti Numbers

In this section we show that the $\mathbb{Z}/2\mathbb{Z}$ -Betti numbers of a real Calabi-Yau toric hypersurface are independent of the chosen toric SPC-desingularization, which is an analogue to an aforementioned result of Batyrev on complex Calabi-Yau varieties. We show that this is not true for Betti numbers with integral coefficients.

The remaining part of the section is mostly devoted to the calculation of the Euler characteristic of those hypersurfaces which have been constructed by using Viro's patchworking method. We show that if the triangulation used in the patchworking method is unimodular, then the Euler characteristic is independent of the particular choice of the triangulation and of the sign function on its vertices. For real K3 surfaces it turns out that only two different types of surfaces are obtained in this way.

If the Euler characteristic is known (e.g. for odd-dimensional varieties it must always be zero) this allows us to derive a relation between a reflexive polytope and its dual.

4.5.1 Proposition: *Let $\Delta \subset \mathbb{R}^d$ be a reflexive polytope, Z a Δ -regular hypersurface and \tilde{Z} the real Calabi-Yau variety resulting from a toric SPC-desingularization φ . Then the cohomology groups with $\mathbb{Z}/2\mathbb{Z}$ -coefficients do not depend on the particular choice of the desingularization.*

Proof: From the stratification of Z into intersections with torus orbits, additivity of the virtual Poincaré polynomial β (see proposition 2.3.2) and theorem 4.1.8, it follows that

$$\begin{aligned} \beta(\tilde{Z}; t) &= \beta\left(\bigcup_{\Gamma \text{ face of } \Delta} \varphi_{\mathcal{T}}^{-1}(Z_{\Gamma}); t\right) \\ &= \beta\left(\bigcup_{\Gamma} Z_{\Gamma} \times \varphi_{\Gamma^*, \mathcal{T}}^{-1}(p_{\Gamma^*}); t\right) \\ &= \sum_{\Gamma} \beta(Z_{\Gamma}; t) \beta(\varphi_{\Gamma^*, \mathcal{T}}^{-1}(p_{\Gamma^*}); t). \end{aligned}$$

As the virtual Poincaré polynomial of a smooth real local toric Calabi-Yau variety does not depend on the triangulation (see proposition 3.2.6), the right-hand term of the above sum does not depend on it either, and hence the same is valid for the whole expression. But \tilde{Z} is a smooth compact real algebraic variety and hence virtual and classical Betti numbers coincide. The cohomology groups with $\mathbb{Z}/2\mathbb{Z}$ -coefficients are defined (up to isomorphism) by their dimension, which concludes the proof. \square

4.5.2 Theorem: Let $\Delta = \text{conv}(\pm e_1, \dots, \pm e_4)$ be the 4-dimensional crosspolytope with dual Δ^* , which is the 4-dimensional cube $[-1, 1]^4$. Let Z be a Δ -regular hypersurface in X_Δ . Let $\mathcal{T}, \mathcal{T}'$ be the triangulations of the square $[-1, 1]^2$ as shown in the figures 4.35 and 4.36. As the 2-dimensional faces of Δ^* are all such squares, \mathcal{T} and \mathcal{T}' define triangulations on Δ^* , which we also call \mathcal{T} and \mathcal{T}' (the slight ambiguity should not lead to any problems). \mathcal{T} and \mathcal{T}' are unimodular and coherent, so they define SPC-desingularizations \tilde{Z} and \tilde{Z}' of Z .

Then

$$H_1(\tilde{Z}, \mathbb{Z}) \cong H_1(\tilde{Z}', \mathbb{Z}).$$

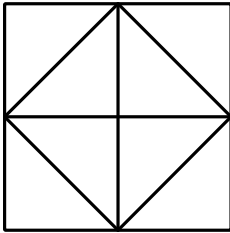

Figure 4.35: The triangulation \mathcal{T}

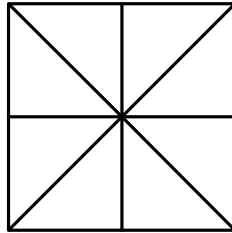

Figure 4.36: The triangulation \mathcal{T}'

Proof: Let p_1, \dots, p_m denote the singular points of Z that correspond (in the sense of proposition 4.1.9; in that notation it is the

correspondence $p \in Z_\Gamma \leftrightarrow \Gamma^*$) to a 2-dimensional face of Δ^* (these can also be described as the intersection of Z with the singular 1-dimensional torus orbits of X_Δ).

Let A, A' denote the preimages of $Z \setminus \{p_i\}$ in the respective desingularizations. We can naturally identify A with A' as the singularities of Z which are not of the above type correspond to edges of Δ^* . But \mathcal{T} and \mathcal{T}' coincide on the edges, so the desingularizations are identical. Let B, B' denote the real local toric Calabi-Yau varieties associated with \mathcal{T} and \mathcal{T}' .

Without loss of generality we can assume that $m = 1$, so

$$\begin{aligned} \tilde{Z} &= \bar{A} \cup \bar{B}, \text{ with } \bar{A} \cap \bar{B} = \partial \bar{A} = \partial \bar{B} \cong T_6 \\ \tilde{Z}' &= \bar{A} \cup \bar{B}', \text{ with } \bar{A} \cap \bar{B}' = \partial \bar{A} = \partial \bar{B}' \cong T_6, \end{aligned}$$

where the last equality in each line follows from propositions 3.2.5 and 3.2.8 and the fact that the Euler characteristic of an orientable surface T_g is $2 - 2g$.

The Mayer-Vietoris sequence for reduced homology ends with the following terms:

$$H_1(\bar{A} \cap \bar{B}) \xrightarrow{(i_*, j_*)} H_1(\bar{A}) \oplus H_1(\bar{B}) \xrightarrow{(k_* - l_*)} H_1(\tilde{Z}) \longrightarrow \tilde{H}_0(\bar{A} \cap \bar{B}) = 0,$$

as $\bar{A} \cap \bar{B}$ is path-connected. Thereby we use the notation

$$\begin{aligned} i : \bar{A} \cap \bar{B} &\hookrightarrow \bar{A}, & k : \bar{A} &\hookrightarrow \tilde{Z}, \\ j : \bar{A} \cap \bar{B} &\hookrightarrow \bar{B}, & l : \bar{B} &\hookrightarrow \tilde{Z}. \end{aligned}$$

H^i denotes the homology with integral coefficients. It follows that

$$\begin{aligned} H_1(\tilde{Z}) &\cong H_1(\bar{A}) \oplus H_1(\bar{B}) / \text{Ker}(k_* - l_*) \\ &\cong H_1(\bar{A}) \oplus H_1(\bar{B}) / \text{Im}(i_* - j_*) \\ &\cong H_1(\bar{A}) / \text{Im}(i_*) \oplus H_1(\bar{B}) / \text{Im}(j_*). \end{aligned}$$

The same is valid for B' and \tilde{Z}' instead of B and \tilde{Z} . In both $H_1(\tilde{Z})$ and $H_1(\tilde{Z}')$ the same direct summand $H_1(\bar{A}) / \text{Im}(i_*)$ occurs. So it suffices to show that $H_1(\bar{B}) / \text{Im}(j_*) \not\cong H_1(\bar{B}') / \text{Im}(j'_*)$.

We claim the following facts:

- a) $H_1(\overline{B})/\text{Im}(j_*) = 0$, or equivalently, j_* is surjective.
- b) $H_1(\overline{B}')/\text{Im}(j'_*) \neq 0$, or equivalently, j'_* is not surjective.

Surjectivity of the map j_* can also be formulated as follows: j_* is surjective if and only if for every $c \in H_1(\overline{B})$ there is a $\tilde{c} \in H_1(\partial\overline{B})$ such that \tilde{c} is homologous to c within \overline{B} .

To a): By proposition 3.2.17 and arguments used in the explanation of conjecture 3.4.4, \overline{B} can be obtained from $T_1 \times [-1, 1]$ by glueing a 1-handle connecting $T_1 \times \{-1\}$ with $T_1 \times \{+1\}$ and further glueing of 3 1-handles at an arbitrary place. The glueing of the last 3 1-handles can also be viewed as the attachment of the solid 2-torus, which we denote by Q_2 . We have schematically depicted \overline{B} in figure 4.37, but without the Q_2 in order to make the picture simpler.

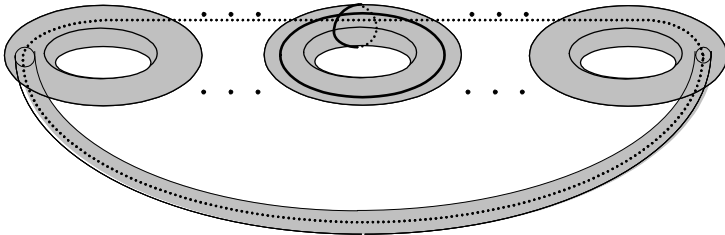

Figure 4.37: \overline{B} and the generators of H_1

$H_1(\overline{B})$ is generated by the generators of $H_1(T_1)$ (identifying T_1 with $T_1 \times \{0\}$) and 1 generator per 1-handle. A 1-handle, together with a part of \overline{B} , can be identified with a solid 1-torus $Q_1 \cong S^1 \times B^2$; then the generator can be identified with $S^1 \times \{0\}$. We will call such a generator the *core* of the 1-handle.

$H_1(\partial\overline{B})$ is generated by

- the generators of $H_1(T_1)$, when T_1 is identified with $T_1 \times \{-1\}$,

- the generators of $H_1(T_1)$, when T_1 is identified with $T_1 \times \{+1\}$,
- the generators of $H_1(\partial Q_2) = H_1(T_2)$.

The first two types of generators clearly map surjectively to the generators of $H_1(T_1 \times \{0\})$ as for every $c \in H_1(T_1 \times \{0\})$, c is homologous within $T_1 \times [-1, 1]$ to $c \in H_1(T_1 \times \{1\})$. The cores of the 1-handles can clearly be “pushed out” to the boundary of the 1-handle.

To b): By proposition 3.2.17 $\overline{B'}$ is the anticanonical bundle, or in topological terms the orientation bundle, over $T_2 \# \mathbb{R}P^2 \# \mathbb{R}P^2 =: M_6$ (M_6 can be thought of T_2 containing two Möbius discs). It follows that $\partial \overline{B'}$ is a double cover of M_6 , which is trivial on T_2 (without the Möbius discs). The two copies of the cover of the boundary of a Möbius disc are connected by a tube. We have schematically depicted the situation in figure 4.38 (with T_1 instead of T_2).

$H_1(\overline{B'})$ is generated by the generators of $H_1(T_2)$ and the generators of the first homology group of the Möbius discs. It is easy to verify that the boundary of a Möbius disc is homologous to two times such a generator. But such a boundary is homologous within $\overline{B'}$ to a generator of the above described tube, which is also a generator of $H_1(\partial \overline{B'})$. So j'_* is not surjective, since both generators of $H_1(\overline{B'})$ lying inside the Möbius discs are not contained in the image. □

We now turn to the calculation of the Euler characteristic of Calabi-Yau toric hypersurfaces which have been constructed with combinatorial patchworking.

Let $\Delta \subset \mathbb{R}^d$ be a lattice polytope, \mathcal{T} a triangulation of it.

For any $\sigma \in \mathcal{T}$ let Γ_σ denote the minimal face of Δ containing σ . We set

$$G_\sigma := \mathbb{S}_{\Gamma_\sigma},$$

where we recall from section 1.2 that $\mathbb{S}_{\Gamma_\sigma} = \text{Hom}(\text{Lin}(\Gamma_\sigma) \cap \mathbb{Z}^d, \{\pm 1\})$ is a \mathbb{F}_2 -vector space of dimension $\dim \Gamma_\sigma$. We further recall that for $\sigma \subset \sigma'$ we have a natural inclusion $G_\sigma \subset G_{\sigma'}$ and that any $\xi \in G_\sigma$ can naturally be regarded as linear form on $(\mathbb{F}_2)^d$.

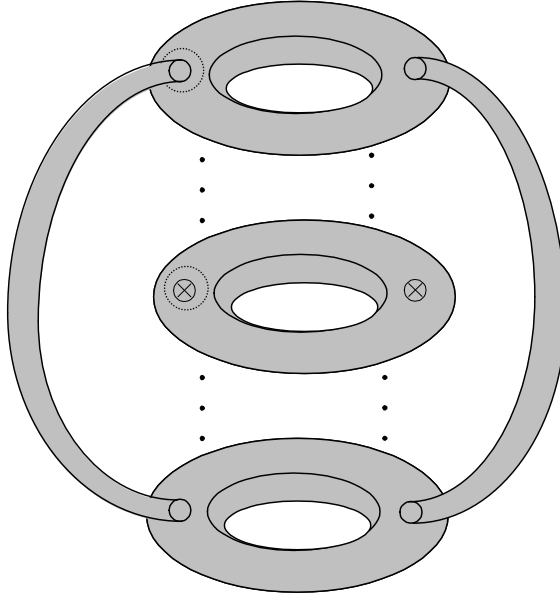

Figure 4.38: M_6 and the double cover $\partial\overline{B'}$. The dotted circles are homologous in $\overline{B'}$

4.5.3 Proposition: *Let $\Delta \subset \mathbb{R}^d$ be a d -dimensional lattice polytope and \mathcal{T} a lattice triangulation of it. Let \mathcal{T}_{X_Δ} be the induced triangulation of the real toric variety X_Δ . Then for any $\sigma \in \mathcal{T}$ there are exactly $2^{\dim \Gamma_\sigma}$ copies of σ in \mathcal{T}_{X_Δ} , one for each $\xi \in G_\sigma$.*

Proof: In the notation of section 1.2 the copies $\Gamma^{(\xi)}$ and $\Gamma^{(\xi')}$ of a face Γ of Δ are identified exactly when $\xi \equiv \xi' \pmod{N_{\Delta/\Gamma}}$. The remaining copies of Γ in \mathcal{T}_{X_Δ} are in one-to-one correspondence with $\mathbb{S}_\Delta/N_{\Delta/\Gamma}$, which is isomorphic to \mathbb{S}_Γ by proposition 1.2.24. \square

Let $\sigma \in \mathcal{T}$ be fixed for the following considerations and denote by v_0, v_1, \dots, v_k its vertices. In Viro's patchworking method any sign

function on the vertices defines a cell, which separates positive from negative signs. It is clear that reversing all signs leads to the same cell, so we can always assume that v_0 carries a positive sign. Thus we restrict our attention to the following set of sign functions

$$E_\sigma := \{\varepsilon : \{v_1, \dots, v_k\} \rightarrow \{\pm 1\}\}.$$

G_σ operates on E_σ by

$$\varepsilon^{(\xi)}(v_i) := \xi^{v_i} \varepsilon(v_i).$$

(This notation is consistent with the fact that $\varepsilon^{(\xi)}$ denotes the sign function on $\sigma^{(\xi)}$.)

We will write $[\varepsilon]$ for the orbit of ε under the action of G_σ and $\mathbf{1}$ for the function ε such that $\varepsilon(v_i) = 1$ for all $i = 1, \dots, k$.

The stabilizer (of any $\varepsilon \in E_\sigma$) is

$$\text{St}_\sigma := \{\xi \in G_\sigma \mid \xi^{v_i} = 1 \ \forall i = 1, \dots, k\}.$$

As we may replace v_i by its image $\bar{v}_i \in \mathbb{Z}/2\mathbb{Z}$ we get

$$\text{St}_\sigma = \{\xi \in G_\sigma \mid \xi|_{\text{Lin}_2(\sigma)} \equiv 1\}.$$

Remark: We can naturally identify $G_\sigma/\text{St}_\sigma$ with $\text{Hom}(\text{Lin}_2(\sigma), \{\pm 1\})$. In particular, $|\text{St}_\sigma| = 2^{\dim \Gamma_\sigma - \dim_2 \sigma}$.

4.5.4 Proposition: *For any $\varepsilon_\sigma \in E_\sigma$ the orbit $[\varepsilon_\sigma]$ contains exactly $2^{\dim_2 \sigma}$ sign functions and E_σ contains exactly $2^{\dim \sigma - \dim_2 \sigma}$ different orbits.*

Proof: The length of an orbit is equal to

$$\begin{aligned} |G_\sigma|/|\text{St}_\sigma| &= 2^{\dim \Gamma_\sigma} / 2^{\dim \Gamma_\sigma - \dim_2 \sigma} \\ &= 2^{\dim_2 \sigma}. \end{aligned}$$

The second statement follows immediately with $|E_\sigma| = 2^{\dim \sigma}$. \square

In the following let $\Delta \subset \mathbb{R}^d$ be a lattice polytope and \mathcal{T} a coherent lattice triangulation of it. We set $f_i := \#\mathcal{T}(i)$ and

$$f_{i,j} := \#\{\sigma \in \mathcal{T}(i) \mid \dim \Gamma_\sigma = j\}.$$

In particular $f_{i,j} = 0$ if $i > j$ and $\sum_j f_{i,j} = f_i$.

Let ε be a sign function on the vertices of the triangulation and Z the hypersurface constructed by patchworking using these data. For any $\sigma \in \mathcal{T}$ let ε_σ be the sign function $\pm\varepsilon|_\sigma$ such that there is a vertex with positive sign, which takes the role of v_0 .

4.5.5 Theorem: *The Euler number of Z can be expressed as*

$$\begin{aligned} \chi(Z) &= \sum_{i=1}^n (-1)^{i-1} \sum_{j=i}^n 2^j f_{i,j} \\ &\quad - \sum_{i=1}^n (-1)^{i-1} \sum_{j=i}^n \sum_{\substack{\sigma \in \mathcal{T}(i): \\ \dim \Gamma_\sigma = j \\ \mathbf{1} \in [\varepsilon_\sigma]}} 2^{j - \dim_2 \sigma}. \end{aligned}$$

Remark: Note that the first term in the above formula does not depend on the choice of signs. With additional assumptions it does not depend on the triangulation either, as we will show later.

In the second term, there is a choice to make for the signs of every simplex σ with $\dim_2 \sigma < \dim \sigma$. As it is easy to see, choosing them in the orbit of $\mathbf{1}$ makes the Euler characteristic smaller, choosing them otherwise makes it bigger. But unfortunately, depending on the triangulation, these choices may not be made independently for each $\sigma \in \mathcal{T}$.

Proof: We know that $Z_{\sigma(\xi)} = \emptyset$ if and only if the sign function $\varepsilon_\sigma^{(\xi)} = \mathbf{1}$. In the other cases, it is a $(\dim \sigma - 1)$ -cell. So we get a cell decomposition

$$\{Z_{\sigma(\xi)} \mid \sigma \in \mathcal{T} \text{ with } \dim \sigma \geq 1, \xi \in G_\sigma \text{ such that } \varepsilon_\sigma^{(\xi)} \neq \mathbf{1}\}$$

of Z . Note that if $\mathbf{1} \in [\varepsilon_\sigma]$, then

$$\#\{\xi \in G_\sigma \mid \varepsilon_\sigma^{(\xi)} = \mathbf{1}\} = |\text{St}_\sigma| = 2^{\dim \Gamma_\sigma - \dim_2 \sigma}.$$

So the Euler characteristic of Z amounts to

$$\begin{aligned} \chi(Z) &= \sum_{\sigma \in \mathcal{T}, \dim \sigma \geq 1} \sum_{\substack{\xi \in G_\sigma: \\ \varepsilon_\sigma^{(\xi)} \neq \mathbf{1}}} (-1)^{\dim \sigma - 1} \\ &= \sum_{\sigma \in \mathcal{T}} \sum_{\xi \in G_\sigma} (-1)^{\dim \sigma - 1} - \sum_{\sigma \in \mathcal{T}} \sum_{\substack{\xi \in G_\sigma: \\ \varepsilon_\sigma^{(\xi)} = \mathbf{1}}} (-1)^{\dim \sigma - 1} \\ &= \sum_{i=1}^n \sum_{j=i}^n \sum_{\substack{\sigma \in \mathcal{T}(i): \\ \dim \Gamma_\sigma = j}} \sum_{\xi \in G_\sigma} (-1)^{i-1} \\ &\quad - \sum_{i=1}^n \sum_{j=i}^n \sum_{\substack{\sigma \in \mathcal{T}(i): \\ \dim \Gamma_\sigma = j \\ \mathbf{1} \in [\varepsilon_\sigma]}} \sum_{\substack{\xi \in G_\sigma: \\ \varepsilon_\sigma^{(\xi)} = \mathbf{1}}} (-1)^{i-1} \\ &= \sum_{i=1}^n (-1)^{i-1} \sum_{j=i}^n f_{i,j} 2^j - \sum_{i=1}^n (-1)^{i-1} \sum_{j=i}^n \sum_{\substack{\sigma \in \mathcal{T}(i): \\ \dim \Gamma_\sigma = j \\ \mathbf{1} \in [\varepsilon_\sigma]}} 2^{j - \dim_2 \sigma} \end{aligned}$$

□

Remark: One can also write the formula as follows:

$$\begin{aligned} \chi(Z) = & -\chi(X_\Delta) + \sum_{l=0}^n 2^l \chi(\tilde{\Delta}(l)) \\ & + \sum_{i=1}^n (-1)^i \sum_{j=i}^n 2^{j-i} \left[-f_{i,j}^- + \sum_{k=0}^{i-1} (2^{i-k} - 1) f_{i,j,k}^+ \right], \end{aligned}$$

where

$$\tilde{\Delta}(l) := \bigcup_{\substack{\sigma \in \mathcal{T}: \\ \dim \Gamma_\sigma = \dim \sigma + l}} \sigma,$$

$f_{i,j,k}$ denotes the number of simplices $\sigma \in \mathcal{T}$ with $\dim \sigma = i$, $\dim \Gamma_\sigma = j$ and $\dim_2 \sigma = k$; the $(+)$ denotes the number of respective simplices σ for which $\varepsilon_\sigma \in [\mathbf{1}]$ and $(-)$ denotes the number of the other ones.

Again, the first line in the formula is independent of the triangulation and the sign function, whereas the dependent part is encoded in the second line.

Proof: We have

$$\begin{aligned} \chi(Z) = & \sum_{i=1}^n (-1)^{i-1} \sum_{j=i}^n \left[2^j f_{i,j} - \sum_{\substack{\sigma \in \mathcal{T}(i): \\ \dim \Gamma_\sigma = j \\ \varepsilon_\sigma \in [\mathbf{1}]}} 2^{j - \dim_2 \sigma} \right] \\ = & \sum_{i=1}^n (-1)^{i-1} \sum_{j=i}^n \left[2^j f_{i,j} - \sum_{k=0}^i 2^{j-k} f_{i,j,k}^+ \right] \end{aligned}$$

$$\begin{aligned}
&= \sum_{i=1}^n (-1)^{i-1} \sum_{j=i}^n \left[2^j f_{i,j} - 2^{j-i} \sum_{k=0}^i 2^{i-k} (f_{i,j,k} - f_{i,j,k}^-) \right] \\
&= \sum_{i=1}^n (-1)^{i-1} \sum_{j=i}^n \left[(2^j - 2^{j-i}) f_{i,j} \right. \\
&\quad \left. - 2^{j-i} \left(-f_{i,j}^- + \sum_{k=0}^i (2^{i-k} - 1) (f_{i,j,k} - f_{i,j,k}^-) \right) \right].
\end{aligned}$$

Now it is enough to calculate the first part:

$$\begin{aligned}
&\sum_{i=1}^n (-1)^{i-1} \sum_{j=i}^n (2^j - 2^{j-i}) f_{i,j} \\
&= \sum_{i=0}^n (-1)^{i-1} \sum_{j=i}^n (2^j - 2^{j-i}) f_{i,j}.
\end{aligned}$$

The first term of this amounts to

$$\begin{aligned}
&\sum_{j=0}^n 2^j \sum_{i=0}^j (-1)^{i-1} f_{i,j} \\
&= - \sum_{j=0}^n 2^j \chi(\text{Int}(\Delta(j))) \\
&= - \chi(X_\Delta),
\end{aligned}$$

whereas the second can be transformed into

$$\sum_{l=0}^n \sum_{i=0}^{n-l} (-1)^i 2^l f_{i,i+l}$$

with the change of variables $l := j - i$, concluding the proof. \square

Example:

- a) It follows a very easy example in order to make the notation clear (see figure 4.39):

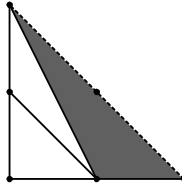
Figure 4.39: Triangulation of Δ

The matrix $(f_{i,j})$ is given as follows:

$$\begin{pmatrix} 3 & 2 & 0 \\ 0 & 5 & 2 \\ 0 & 0 & 3 \end{pmatrix}$$

There is exactly one 2- and one 3-dimensional simplex, for which $\dim_2 \sigma = \dim \sigma - 1$ (the dotted, respectively the grey one in figure 4.39), for all other ones $\dim_2 \sigma = \dim \sigma$. So there are (essentially) two choices for the sign functions, which are shown in figures 4.40 and 4.41.

So, with the first formula the independent part of the Euler characteristic amounts to

$$\begin{aligned} \chi_1 &= (1 \cdot 0 + 2 \cdot 5 + 4 \cdot 2) \\ &\quad - (1 \cdot 0 + 2 \cdot 0 + 4 \cdot 3) \\ &= 6. \end{aligned}$$

The part that depends on the choice of signs amounts to

$$\begin{aligned} \chi_2 &= (1 \cdot 4 + 2 \cdot \delta + 2 \cdot 2) \\ &\quad - (1 \cdot 2 + 2 \cdot \delta) \\ &= 6, \end{aligned}$$

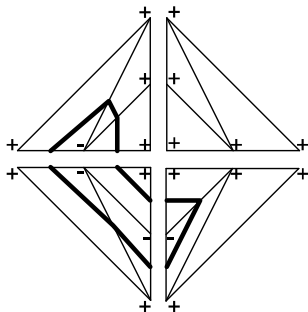

Figure 4.40: Sign function and curve, case a)

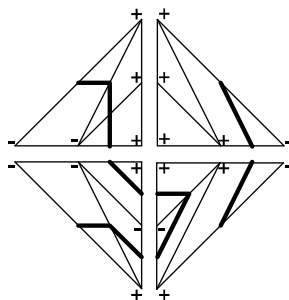

Figure 4.41: Sign function and curve, case b)

where $\delta = 1$ in case a) and $\delta = 0$ in case b). In all cases $\chi(Z) = \chi_1 - \chi_2 = 0$ as it should be for a real compact curve. We can also get this result with the second formula. Here the independent term amounts to

$$\begin{aligned} \chi_1 &= -\chi(\mathbb{RP}^2) + 1 \cdot (3 - 5 + 3) + 2 \cdot (2 - 2) + 4 \cdot 0 \\ &= -1 + 1 = 0. \end{aligned}$$

In case a) we have $f_{i,j}^- = 0$ for all i, j and $f_{1,1,0}^+ = f_{2,2,1}^+ = 1$, whereas the other $f_{i,j,k}^+$ are zero for $k \geq 1$. So

$$\chi_2 = -1 \cdot 1 + 1 \cdot 1 = 0.$$

In case b) we have $f_{1,1}^- = f_{2,2}^- = 1$ and all other $f_{i,j}^- = 0$, whereas $f_{i,j,k}^+ = 0$ for all $k \geq 1$. So,

$$\chi_2 = 1 \cdot 1 - 1 \cdot 1 = 0.$$

Again, in all cases $\chi(Z) = \chi_1 - \chi_2 = 0$.

- b) Let $\Delta' \subset \mathbb{R}^2$ be the triangle with vertices $(0, 0), (6, 0), (0, 6)$ with a maximal coherent triangulation \mathcal{T}' . Let $\Delta \subset \mathbb{R}^3$ be the simplex spanned by $\Delta' \times \{0\}$ and the point $p := (0, 0, 2)$ (note that

Δ is a reflexive polytope). Let \mathcal{T} be the induced triangulation on Δ . By setting signs on the vertices we get two related real varieties: $Z' \subset X_{\Delta'} \cong \mathbb{R}\mathbb{P}^2$, which is a curve of degree 6 and hence divides $\mathbb{R}\mathbb{P}^2$ into two sets, which we call \mathbb{P}_+^2 and \mathbb{P}_-^2 . The other one is $Z \subset X_{\Delta}$, which is a double covering of either \mathbb{P}_+^2 or \mathbb{P}_-^2 , branched along Z' . If we assume that the sign at p is positive, then Z is a double covering of \mathbb{P}_-^2 and we know that the Euler characteristic is

$$\chi(Z) = 2\chi(\mathbb{P}_-^2) = 2 - 2\chi(\mathbb{P}_+^2).$$

We can recover this result by the formula of the remark on the Euler characteristic of Z : First we note that \mathbb{P}_+^2 is homeomorphic to the following simplicial subcomplex of X'_{Δ} :

$$X_{\Delta',+} := \bigcup_{\sigma' \in \mathcal{T}'_{\Delta', \varepsilon_{\sigma'} \in \mathbf{1}}} \sigma'$$

and analogously for \mathbb{P}_-^2 .

We have the following matrix $(f'_{i,j}) = (f_{i,j}(\Delta'))$:

$$\begin{pmatrix} 3 & 15 & 10 \\ 0 & 18 & 45 \\ 0 & 0 & 36 \end{pmatrix}$$

We define the matrix $(g_{i,j}) := (f_{i,j} - f'_{i,j})$. Due to the special triangulation we have $f_{i,j} = g_{i+1,j+1}$ for all $i, j = 0, \dots, 2$ and $g_{0,0} = 1$. Note that \mathcal{T}' is unimodular and hence for any $\sigma' \in \mathcal{T}'$ all signs are equal (either all positive or all negative) in exactly one copy of the sign function $\varepsilon_{\sigma'}$. Let $f_{i,j}^+$ be the number of those simplices where these signs are positive.

For the simplices in $\mathcal{T} \setminus \mathcal{T}'$ of the form $\sigma = \overleftrightarrow{p\sigma'}$, where $\sigma' \in \mathcal{T}'$, the situation is the following: The sign function ε_{σ} is in the orbit of $\mathbf{1}$ if and only if σ' counts to some $f_{i,j}^+$. Furthermore, the $\dim_2 \sigma = \dim \sigma - 1$ if and only if σ' has a vertex where all coordinates are even. We call such a simplex an *even simplex*. In the

other cases $\dim_2 \sigma = \dim \sigma$, and we call σ' an *odd simplex*. We introduce the following notation: Denote by $f_{i,j,e}$ the number of even simplices accounting for $f_{i,j}$ and $f_{i,j,o}$ the number of odd simplices.

Now we are able to calculate the Euler characteristic: The sign independent part amounts to

$$\begin{aligned}\chi_1 &= 2 \cdot (3 + 18) + 4 \cdot (15 + 45) + 8 \cdot 10 \\ &\quad - (4 \cdot (18 + 36) + 8 \cdot 45) \\ &\quad + (8 \cdot 36) \\ &= 74.\end{aligned}$$

The dependent part amounts to

$$\begin{aligned}\chi_2 &= 1 \cdot f_{1,1} + 2 \cdot f_{0,0}^+ + 2 \cdot f_{1,2} + 2 \cdot f_{0,1,o}^+ + 4 \cdot f_{0,1,e}^+ \\ &\quad + 4 \cdot f_{0,2,o}^+ + 8 \cdot f_{0,2,e}^+ - 1 \cdot f_{2,2} - 2 \cdot f_{1,1}^+ \\ &\quad - 2 \cdot f_{1,2,o}^+ - 4 \cdot f_{1,2,e}^+ + f_{2,2}^+, \end{aligned}$$

where we note that $f_{0,0} = f_{0,0,e}$ and $f_{1,1} = f_{1,1,e}$. The part without pluses amounts to 72 and it is not difficult to check that the rest amounts to $2\chi(\mathbb{P}_+^2)$. So, altogether, we get

$$\chi(Z) = \chi_1 - \chi_2 = 74 - 72 - \chi(\mathbb{P}_+^2) = 2 - 2\chi(\mathbb{P}_+^2)$$

as we already knew.

Remark: This result is also true for general coherent triangulations of Δ' .

4.5.6 Proposition: *If \mathcal{T} is a unimodular triangulation of Δ , then the numbers $f_{i,j}$ do not depend on the particular choice of triangulation.*

Proof: We already know by corollary 1.2.14 that the numbers $f_i = \sum_j f_{i,j}$ do not depend on the triangulation. We proceed by induction on j to show that also the $f_{i,j}$ are independent.

For $j = 0$ the assertion is clear, as $f_{0,0}$ is the number of vertices of Δ and $f_{i,0} = 0$ for $i > 0$. So we assume now that the assertion is true for all lattice polytopes and all $j = 0, \dots, k-1$ for some $k \geq 1$. We show that it is also true for $j = k$.

For any $\sigma \in \mathcal{T}$ we note that Γ_σ is the unique face Γ of Δ such that $\sigma \cap \text{Int}(\Gamma) \neq \emptyset$. So we get

$$\begin{aligned} f_{i,k} &= \sum_{\Gamma \in \Delta(k)} \#\{\sigma \in \mathcal{T}(i) \mid \sigma \cap \text{Int}(\Gamma) \neq \emptyset\} \\ &= \sum_{\Gamma \in \Delta(k)} \left[\#\{\sigma \in \mathcal{T}(i) \mid \sigma \subset \Gamma\} - \#\{\sigma \in \mathcal{T}(i) \mid \sigma \subset \partial\Gamma\} \right] \\ &= \sum_{\Gamma \in \Delta(k)} f_i(\Gamma) - \sum_{\Gamma \in \Delta(k)} \sum_{F \subsetneq \Gamma} \#\{\sigma \in \mathcal{T}(i) \mid \sigma \cap \text{Int}(F) \neq \emptyset\}, \end{aligned}$$

where the last sum runs over the proper faces of Γ and we write $f_i(\Gamma)$ (and henceforth also $f_{i,k}(\Gamma)$) for the numbers defined by the induced triangulation on Γ .

The first term of the last expression is independent of the triangulation by corollary 1.2.14. The second sum in the right hand term is equal to

$$\sum_{j=0}^{k-1} \sum_{F \in \Gamma(j)} \#\{\sigma \in \mathcal{T}(i) \mid \sigma \cap \text{Int}(F) \neq \emptyset\}.$$

The second sum of this expression is equal to $f_{i,j}(\Gamma)$ and is thus by induction hypothesis independent of the triangulation. \square

4.5.7 Proposition: *Let \mathcal{T} be a unimodular coherent triangulation of a lattice polytope Δ and Z the real hypersurface of X_Δ defined by some choice of signs on the vertices of \mathcal{T} . For any $\sigma \in \mathcal{T}(i)$ with $\dim \Gamma_\sigma = j$ there are 2^j copies of σ in \mathcal{T}_{X_Δ} . Of those, 2^{j-i}*

have empty intersection with Z . In particular, these numbers are independent of the choice of signs.

Proof: We have already shown in proposition 4.5.3 the statement on the numbers of copies of σ in $\overline{\mathcal{T}}_{X_\Delta}$.

To prove the second statement let v_0, \dots, v_i designate the vertices of σ . As \mathcal{T} is unimodular, $v_1 - v_0, \dots, v_i - v_0$ are part of a \mathbb{Z} -basis of \mathbb{Z}^d , $\bar{v}_1 - \bar{v}_0, \dots, \bar{v}_i - \bar{v}_0$ are part of a \mathbb{F}_2 -basis of $(\mathbb{Z}/2)^d$, hence $\dim_2 \sigma = \dim \sigma = i$. So by proposition (4.5.4) there is only one orbit for the sign functions, and hence, independently of the original choice of sign function, the function $\mathbf{1}$ occurs 2^{j-i} times, which is when the intersection with Z is empty. \square

4.5.8 Proposition: *With the same assumptions as in the previous proposition the Euler number of Z is*

$$\chi(Z) = \sum_{i=1}^n (-1)^{i-1} (2^i - 1) \sum_{j=i}^n 2^{j-i} f_{i,j}.$$

In particular, it is independent of the triangulation and of the choice of signs on the vertices.

Proof: From the previous proposition we get that in the right hand term of theorem 4.5.5 the condition $\varepsilon_\sigma \in [1]$ is always fulfilled and $\dim_2 \sigma = \dim \sigma$ for all $\sigma \in \mathcal{T}$. So the formula of 4.5.5 gets

$$\begin{aligned} \chi(Z) &= \sum_{i=1}^n (-1)^{i-1} \sum_{j=i}^n \sum_{\substack{\sigma \in \mathcal{T}(i): \\ \dim \Gamma_\sigma = j}} (2^j - 2^{j-i}) \\ &= \sum_{i=1}^n (-1)^{i-1} \sum_{j=i}^n f_{i,j} 2^{j-i} (2^i - 1) \\ &= \sum_{i=1}^n (-1)^{i-1} (2^i - 1) \sum_{j=i}^n 2^{j-i} f_{i,j}. \end{aligned}$$

\square

4.5.9 Proposition: *Let Δ be a reflexive 3-dimensional polytope, \mathcal{T} a unimodular coherent triangulation and Z a real hypersurface in X_Δ constructed by Viro's method. Then*

$$\chi(Z) = 8 - f_{1,1}.$$

Proof: In a first step we claim that the following equations are true:

- a) $f_{0,3} = 1,$
- b) $f_{1,3} - f_{2,3} + f_{3,3} = 2,$
- c) $f_{3,3} = f_{2,2},$
- d) $f_{2,3} = f_{1,2} + f_{1,1}.$

By proposition 1.2.4, 0 is the only interior point of Δ , which shows a). To show b) we note that $\sum_{i=0}^3 f_{i,3} = \chi(\text{Int}\Delta) = -1$. Using (a) one gets the desired result.

Now we use the fact that the numbers $f_{i,j}$ are independent of the triangulation, so we can choose the following special one to show the statements: We take \mathcal{T} to be induced by a maximal lattice triangulation of the boundary of Δ . So if $\sigma \in \mathcal{T}$, then $\sigma = \overleftrightarrow{0\sigma'}$ where σ' is a simplex of the triangulation of $\partial\Delta$. Now let σ be any i -dimensional simplex with $\dim \Gamma_\sigma = 3$ (for $1 \leq i \leq 3$). Then $\sigma = \overleftrightarrow{0\sigma'}$ with σ' a simplex in $\partial\Delta$. On the other hand, a simplex σ' in $\partial\Delta$ defines a unique simplex $\sigma = \overleftrightarrow{0\sigma'}$ in Δ . So we have

$$f_{i,3} = \sum_{j=0}^2 f_{i-1,j} = \sum_{j=i-1}^2 f_{i-1,j}$$

for $i = 1, 2, 3$. The case $i = 3$ yields equation (c), the case $i = 2$ yields equation (d).

Now we define the following polynomial $e \in \mathbb{Z}[t]$:

$$e(t) := \sum_{i=1}^3 (-1)^{i-1} [(t+1)^i - 1] \sum_{j=i}^3 f_{i,j} [(t+1)^{j-i}].$$

This is made in such a way that $\chi(Z) = e(1)$ (see prop. 4.5.8).

Carrying out the multiplications, we get

$$\begin{aligned} e(t) = & t [f_{1,1} + f_{1,2} + f_{1,3} - 2f_{2,2} - 2f_{2,3} + 3f_{3,3}] \\ & + t^2 [f_{1,2} + 2f_{1,3} - f_{2,3} - f_{2,2} - f_{2,3} + 3f_{3,3}] \\ & + t^3 [f_{1,3} - f_{2,3} + f_{3,3}]. \end{aligned}$$

Using equation (b) in all three terms, we arrive at

$$\begin{aligned} e(t) = & t [2 + f_{1,1} + f_{1,2} - 2f_{2,2} - f_{2,3} + 2f_{3,3}] \\ & + t^2 [4 + f_{1,2} - f_{2,2} - f_{2,3} + f_{3,3}] \\ & + 2t^3. \end{aligned}$$

Now we use equation (c). The expression simplifies to

$$\begin{aligned} e(t) = & t [2 + f_{1,1} + f_{1,2} - f_{2,3}] \\ & + t^2 [4 + f_{1,2} - f_{2,3}] \\ & + 2t^3. \end{aligned}$$

With the final use of equation (d) we get

$$e(t) = 2t + (4 - f_{1,1})t^2 + 2t^3.$$

Substituting $t = 1$ yields the assertion. \square

4.5.10 Proposition: a) *Let Δ be a 3-dimensional reflexive polytope and Z a real Δ -regular hypersurface in X_Δ . Let Δ^* be the dual polytope of Δ and let a unimodular triangulation \mathcal{T} on $\partial(\Delta^*)$ be given, defining a toric SPC-desingularization φ of X_Δ , respectively Z .*

Then Z_{sing} consists of a finite number of points. For any $p \in Z_{\text{sing}}$ there exists a unique edge $\theta^(p) \subset \Delta^*$ such that p is contained in $Z \cap O_{\text{cone}(\theta^*)}$. Furthermore, p has an analytical neighborhood U in Z , such that U is analytically isomorphic to the real*

toric variety $X_{\Sigma(\theta^*)}$ by an isomorphism mapping p to the unique torus-invariant point x_{θ^*} in $X_{\Sigma(\theta^*)}$. The SPC-desingularization on U is then equivalent to the desingularization of $X_{\Sigma(\theta^*)}$ defined by the induced triangulation on θ^* . More precisely, there is a commutative diagram

$$\begin{array}{ccc} \varphi^{-1}(U) & \xrightarrow{\cong} & X_{\Sigma(\theta^*, \mathcal{T})} , \\ \downarrow & & \downarrow \\ U & \xrightarrow{\cong} & X_{\Sigma(\theta^*)} \end{array}$$

where the horizontal maps are analytical isomorphisms and the vertical maps are the desingularizations defined by \mathcal{T} . In particular the fiber of p in the SPC-desingularization is isomorphic to the fiber of x_{θ^*} in the desingularization $X_{\Sigma(\theta^*, \mathcal{T})} \rightarrow X_{\Sigma(\theta^*)}$.

- b) Assume that furthermore Z is constructed by Viro’s patchworking method using a unimodular coherent triangulation \mathcal{T} of Δ . Then for each edge $\theta \in \Delta(1)$ with dual edge $\theta^* \in \Delta^*(1)$, $Z \cap O_{\text{cone}(\theta^*)}$ consists of $\text{vol}(\theta)$ points. These points are singularities of Z if and only if $\text{vol}(\theta^*) > 1$.

Proof: To a): The singularity locus of X_{Δ} is a union of torus orbits of dimension at most 1. As the torus orbits are met transversally by Z , Z_{sing} has dimension at most 0. For the other statements, see [Bat], theorems 3.1.5 and 4.2.5, compare also proposition 4.1.9 in this work .

To b) Let $\sigma \in \mathcal{T}$ be any maximal simplex in the triangulation of θ . $\mathcal{T}_{X_{\Delta}}$ contains exactly two copies of σ ; we call them σ and σ' . As \mathcal{T} is unimodular, we may assume that $\sigma = [0, 1]$. If ε and ε' are the sign functions on σ and σ' used in the construction of Z , then $\varepsilon(0) = \varepsilon'(0)$ and $\varepsilon(1) = -\varepsilon'(1)$. So only one of σ and σ' carries constant signs on its vertices. It follows that $Z \cap (\sigma \cup \sigma')$ consists of

a single point and

$$Z \cap O_{\text{cone}(\theta^*)} = \bigcup_{\sigma \in \mathcal{T}(1), \sigma \subset \theta} Z \cap (\sigma \cup \sigma'),$$

consists of one point per 1-simplex in θ .

By a) any such point is nonsingular if and only if the surface $X_{\Sigma(\theta^*)}$ is nonsingular. But this is clearly the case if and only if θ^* has length 1. \square

4.5.11 Corollary: *Let Δ be a 3-dimensional reflexive polytope with a unimodular triangulation and Z the hypersurface in X_Δ assigned to some sign function. Let \tilde{Z} be the SPC-desingularization induced by a unimodular triangulation of $\partial\Delta^*$.*

Then

$$\chi(\tilde{Z}) = -16.$$

Proof: Let p be a singularity and $\theta^*(p)$ the corresponding face of Δ^* . In the resolution \tilde{Z} we replace $U(p)$ with Euler characteristic 1 by a real local toric CY-surface, whose Euler number is $2 - \text{vol}(\theta^*)$ by prop. 3.2.5 (note that we can use this description also if $\text{vol}(\theta^*) = 1$, where we replace 1 by 1). So there is one singularity to resolve for each one-dimensional simplex in $\Delta(1)$. With $f_{1,1} = \sum_{\theta \in \Delta(1)} \text{vol}(\theta)$ we get

$$\begin{aligned} \chi(\tilde{Z}) &= 8 - f_{1,1} - \sum_{\theta \in \Delta(1)} \text{vol}(\theta) + \sum_{\theta \in \Delta(1)} \text{vol}(\theta)(2 - \text{vol}(\theta^*)) \\ &= 8 - \sum_{\theta \in \Delta(1)} \text{vol}(\theta)\text{vol}(\theta^*) \\ &= -16 \end{aligned}$$

where the last equation follows from proposition 1.2.5. \square

4.5.12 Proposition: *There are two topological types of real K3 surfaces with Euler characteristic -16 (a sphere plus an oriented surface of genus 10, and an oriented surface of genus 9). Both can be realized with the above described method by using a unimodular triangulation for the combinatorial patchworking.*

Proof: For the possible topological types of the K3 surfaces see the classification in table 4.1 (with $b = 2$). They are distinguished by their number of connected components, namely one or two.

Both can be realized with the 3-cube as polytope and the barycentric triangulation: Take all signs +1 in one case, and change the sign of the inner point to -1 in the second case. It is not difficult to verify that the latter one has at least two components one of which is a 2-sphere. A sketch of a way how to verify by hand the number of components in the first example is the following:

Look at the copy $\Delta^{(\xi)}$ with $\xi = (-1, -1, -1)$ and Δ the cube. Then only the inner point of $\Delta^{(\xi)}$ and the 12 inner points of its edges have positive sign. So the hypersurface in $\Delta^{(\xi)}$ looks like a sphere with 12 tubes sticking out in direction of the edges. Assume now that the hypersurface has a second component. This must lie in the remaining copies ($\xi \neq \pm(1, 1, 1)$) of Δ . Assume further that one of these remaining copies $\Delta^{(\xi')}$ does not contain any part of this second component. Permuting indices and using the symmetry of the whole construction shows that $\Delta^{(\xi')}$ must intersect a third component. But this is impossible due to our knowledge of real K3 surfaces. So the second component already intersects all 6 copies $\Delta^{(\xi)}$ with $\xi \neq \pm(1, 1, 1)$. But such a “long” component does not exist as can be verified relatively easily.

An alternative is using the Maple procedure “HS_NrOfComp” we wrote especially for this case (available at [VHH]). \square

By Poincaré duality we know that the Euler characteristic of a 3-dimensional closed manifold is zero. The combinatorial formula of proposition 4.5.8 then allows us to derive combinatorial relations between dual pairs of 4-dimensional reflexive polytopes:

4.5.13 Proposition: *Let Δ be a reflexive 4-dimensional polytope admitting a unimodular coherent triangulation. Then*

$$\begin{aligned} & -15f_{4,4} + 14f_{3,4} + 7f_{3,3} - 12f_{2,4} - f_{2,3} - 3f_{2,2} \\ & + f_{1,4} + 4f_{1,3} + 2f_{1,2} + f_{1,1} \\ & = \sum_{F \in \Delta(2)} l(\partial F)(2 - l(F^*)) - \sum_{\Theta \in \Delta(1)} \text{vol}(\Theta)(3 - l(\partial \Theta^*)), \end{aligned}$$

where we write $f_{i,j}$ for $f_{i,j}(\Delta)$.

Proof: Let \tilde{Z} be any real Calabi-Yau toric hypersurface constructed by combinatorial patchworking in Δ and a unimodular coherent triangulation \mathcal{T} of Δ^* . As its Euler characteristic is zero, the Euler characteristic of Z must be levelled out by the contribution of the desingularization. The left hand side of the above equation is just proposition 4.5.8 for Z (we will abbreviate it by LHS). So it remains to show that the term on the right hand side gets subtracted in the process of desingularization. Running along the same line as in the proof of proposition 4.5.10 and using theorem 4.1.8 (in particular its notation) and the results on the Euler characteristic of real local toric Calabi-Yau varieties we come to the following conclusions:

- For each 2-dimensional face F of Δ , Z_F is 1-dimensional and its desingularization is described by the 1-dimensional face F^* and the corresponding real local toric K3 surface $X_{\Sigma(F^*, \mathcal{T})}$. This surface has Euler characteristic $2 - \text{vol}(F^*) = 3 - l(F^*)$ by proposition 3.2.5. For each 2-dimensional simplex σ in the triangulation of F , $Z_F \cap \text{Int}(\sigma)$ is homeomorphic to the open interval $I^\circ = (-1, 1)$. In \tilde{Z} this is replaced by $I^\circ \times \varphi_{F^*, \mathcal{T}}^{-1}(x_F^*)$. The last term differs from $X_{\Sigma(F^*, \mathcal{T})}$ by a punctured open disc with Euler characteristic 0, thus the desingularization accounts for an additional $-(2 - l(F^*))$ in the Euler characteristic. As exactly 3 copies of σ carry non-constant signs, this happens three times.

For each 1-dimensional simplex σ in the triangulation of F , $Z_F \cap \text{Int}(\sigma)$ is homeomorphic to a point. In \tilde{Z} this is replaced

by $\varphi_{F^*, \mathcal{T}}^{-1}(x_F^*)$, thus accounting for an additional $(2 - l(F^*))$ in the Euler characteristic. As exactly 2 copies of σ carry non-constant signs, this happens twice.

- For each 1-dimensional face Θ of Δ , Z_Θ is a point and its desingularization is described by the real local toric K3 surface $X_{\Sigma(\Theta^*, \mathcal{T})}$. This surface has Euler characteristic $l(\partial\Theta^*) - 4$ by proposition 3.2.5. Only 1-dimensional simplices of the triangulation of Θ come into account. The intersections $Z_\Theta \cap \text{Int}(\sigma)$ are points, which are replaced in \tilde{Z} by $\varphi_{\Theta^*, \mathcal{T}}^{-1}(x_\Theta^*)$. This differs from $X_{\Sigma(\Theta^*, \mathcal{T})}$ by a punctured open 3-ball with Euler characteristic 2, thus the desingularization accounts for an additional $-(3 - l(\partial\Theta^*))$ in the Euler characteristic. As exactly 1 copy of σ carries non-constant signs, this happens exactly once.

Thus the above equation becomes

$$\begin{aligned} \text{LHS} = & 3 \sum_{F \in \Delta(2)} \text{vol}(F)(2 - l(F^*)) - 2 \sum_{F \in \Delta(2)} f_{1,2}(F)(2 - l(F^*)) \\ & - \sum_{\Theta \in \Delta(1)} \text{vol}(\Theta)(3 - l(\partial\Theta^*)). \end{aligned}$$

Putting the first two terms of the right-hand side together and writing κ, κ^∂ and κ^* for the number of edges, number of edges in the boundary resp. number of edges in the interior of F in any unimodular triangulation, we get

$$\sum_{F \in \Delta(2)} (3 \text{vol} - 2\kappa^*)(2 - l^\partial(F^*)).$$

As by the Euler characteristic of F we have

$$\text{vol} - \kappa^\partial - \kappa^* + l = 1$$

and

$$\text{vol} = l + l^* - 2$$

(see 1.2.11) we can simplify

$$\begin{aligned}
 3\text{vol} - 2\kappa^* &= \text{vol} + 2(1 + \kappa^\partial - l) \\
 &= l + l^* - 2 + 2 + 2\kappa^\partial - 2l \\
 &= -l + l^* + 2\kappa^\partial \\
 &= -l^\partial + 2\kappa^\partial \\
 &= l^\partial,
 \end{aligned}$$

where the last equality is due to the obvious equality $\kappa^\partial = l^\partial$. This concludes the proof. \square

4.6 Computer experiments

The Experiments

A The 4-Dimensional Small Simplex

- $\Delta = \text{conv}(e_1, \dots, e_4, -e_1 - \dots - e_4)$,
- $\Delta \cap \mathbb{Z}^4 = \{0, e_1, \dots, e_4, -e_1 - \dots - e_4\}$,
- Triangulation: unique,
- $\chi(Z) = 0$.

Sign function	H_0	H_1	H_2	H_3
all vertices '+':	\mathbb{Z}	$\mathbb{Z}/2$	0	\mathbb{Z}
0 gets assigned '-':	\mathbb{Z}^2	$\mathbb{Z}/2$	0	\mathbb{Z}^2

Remark: The above tests comprise all combinatorially distinct sign distributions. Note further that one component of the second hypersurface is a sphere, so the other component has the same cohomology as the unique component of the first one.

B The 4-Dimensional Crosspolytope

- $\Delta = \text{conv}(\pm e_1, \dots, \pm e_4)$,
- $\Delta \cap \mathbb{Z}^4 = \{0, \pm e_1, \dots, \pm e_4\}$,
- Triangulation: unique,
- $\chi(Z) = 24$.

Sign function	H_0	H_1	H_2	H_3
all vertices '+':	\mathbb{Z}^2	$\mathbb{Z}^4 \times \mathbb{Z}/2$	\mathbb{Z}^{34}	\mathbb{Z}^8
e_1 : '-':	\mathbb{Z}	$\mathbb{Z}/2$	\mathbb{Z}^{31}	\mathbb{Z}^8
e_1, e_2 : '-':	\mathbb{Z}^2	$\mathbb{Z}^4 \times \mathbb{Z}/2$	\mathbb{Z}^{34}	\mathbb{Z}^8
e_1, e_2, e_3 : '-':	\mathbb{Z}^2	$\mathbb{Z}^4 \times \mathbb{Z}/2$	\mathbb{Z}^{34}	\mathbb{Z}^8
e_1, \dots, e_4 : '-':	\mathbb{Z}^2	$\mathbb{Z}^4 \times \mathbb{Z}/2$	\mathbb{Z}^{34}	\mathbb{Z}^8

Remark: The above tests comprise all combinatorially distinct sign distributions.

C The 4-Dimensional Cube

- $\Delta = [-1, 1]^4$,
- $\Delta \cap \mathbb{Z}^4 = \{-1, 0, 1\}^4$,
- Triangulation: barycentric,
- $X_\Delta \cong (\mathbb{P}^1)^4$,
- $\chi(Z) = 0$, Z is smooth.

Set

$$V_i := \{v \in \Delta \cap \mathbb{Z}^4 \mid \text{exactly } i \text{ coord. of } v \text{ are } 0\}$$

$$= \{v \in \text{Int}(\Gamma) \cap \mathbb{Z}^4 \mid \Gamma \in \Delta(i)\}.$$

V_0	V_1	V_2	V_3	V_4	Number of components
+	+	+	+	+	1
+	+	+	+	-	2
+	+	+	-	+	1
+	+	+	-	-	2
+	+	-	+	+	1
+	+	-	+	-	1
+	+	-	-	+	1
+	+	-	-	-	1
+	-	+	+	+	1
+	-	+	+	-	2
+	-	+	-	+	1
+	-	+	-	-	2
+	-	-	+	+	1
+	-	-	+	-	1
+	-	-	-	+	1
+	-	-	-	-	1

V_0	V_1	V_2	V_3	V_4	Number of components
-	+	+	+	+	1
-	+	+	+	-	1
-	+	+	-	+	1
-	+	+	-	-	1
-	+	-	+	+	2
-	+	-	+	-	1
-	+	-	-	+	2
-	+	-	-	-	1
-	-	+	+	+	1
-	-	+	+	-	1
-	-	+	-	+	1
-	-	+	-	-	1
-	-	-	+	+	2
-	-	-	+	-	1
-	-	-	-	+	2
-	-	-	-	-	1

Remark: The above tests comprise all sign distributions which are constant on the V_i . Due to limitations of computer power, only the number of components could be calculated. As Z is smooth, Poincaré duality yields that only H_1 remains unknown.

The results can be summarized as follows: 2 components arise if and only if the signs on V_0 and V_2 are equal and opposite to the sign on V_4 . The signs on V_1 and V_3 are irrelevant.

D The 4-Dimensional Simplex related to \mathbb{P}^4/μ_5

- $\Delta = \text{conv}((1, 0, 0, 0), (0, 1, 0, 0), (2, 4, 5, 0), (3, 3, 0, 5), (-6, -8, -5, -5))$
- $\text{vol}(\Gamma) = 5^{\dim \Gamma - 1}$ for all faces Γ of Δ which are not a vertex,
- $\#(\Delta \cap \mathbb{Z}^4) = 26$,
- Triangulation: generated by 0 and the facets (not maximal),

- $X_\Delta \cong \mathbb{P}^4/\mu_5$, where μ_5 is the cyclic group of order 5,
- X_Δ has only isolated singularities, so Z is smooth and $\chi(Z) = 0$.

Sign function	H_0	H_1	H_2	H_3
all vertices '+':	\mathbb{Z}	$\mathbb{Z}/2$	0	\mathbb{Z}
0 gets assigned '-':	\mathbb{Z}^2	$\mathbb{Z}/2$	0	\mathbb{Z}^2

Remark: The above tests comprise all combinatorially distinct sign distributions. Note further that one component of the second hypersurface is a sphere, so the other component has the same cohomology as the unique component of the first one.

Observations and final remarks

We observe that in the calculated homology groups only 2-torsion occurs. This reminds of the situation with complex toric Calabi-Yau hypersurfaces: As Batyrev and Kreuzer showed in [BatKr], of 32 cases with p -torsion there are 29 where $p = 2$, 2 cases with $p = 3$ and one case with $p = 5$. Apart from that, there are 473 800 744 cases with no torsion at all, so it seems that torsion in (co-)homology is more common for real Calabi-Yau varieties than for the complex varieties. Experiment D is precisely the one example where 5-torsion on the cohomology of the complex hypersurface occurs. This can be explained by the fact that the hypersurfaces have a 5-fold cover by a hypersurface in \mathbb{P}^4 . Apparently, for the real hypersurfaces this is no longer true.

It is further interesting that in the calculated examples the number of components of the hypersurface already determines all homology groups. On the other hand, there is a very strong indication that the number of components cannot exceed two (in any dimension). If these two facts were true in general (maybe in some weaker form also), it would greatly decrease the dependency of cohomology on the combinatorial data.

The number of components of a Viro hypersurface (with arbitrary triangulation) generally varies widely and is very problematic to determine with a combinatorial formula (the only bounds known are implicated from the algebraic side). This invites the conjecture that the rigid behaviour encountered when using a unimodular triangulation must have an algebraic reason. It would be an interesting question for further research of what type this connection may be.

Bibliography

- [Bat] V. Batyrev: *Dual polyhedra and mirror symmetry for Calabi-Yau-hypersurfaces in toric varieties*. J. Algebraic Geometry **3** (1994), pp. 493-535
- [Bat2] V. Batyrev: *Birational Calabi-Yau n -folds have equal Betti numbers*. New Trends in Algebraic Geometry, Klaus Hulek et al. (eds.), CUP, 1999, pp. 1-11
- [BatKr] V. Batyrev, M. Kreuzer: *Integral Cohomology and Mirror Symmetry for Calabi-Yau 3-Folds*. AMS/IP Studies in Advanced Mathematics **38** (2006)
- [BCR] J. Bochnak, M. Coste and M-F. Roy: *Géométrie algébrique réelle*. Springer-Verlag, New York-Berlin-Heidelberg, 1987
- [Bert] B. Bertran: *Hypersurfaces et intersections complètes maximales dans les variétés toriques*. Ph. D. thesis, Institut de Recherche Mathématique de Rennes, 2002
- [BFCH] Frédéric Bihan, Matthias Franz, Clint McCrory and Joost van Hamel: *Is Every Toric Variety an M-Variety?* . Manuscripta Mathematica **120** (2006), pp. 217-232

- [Cal] E. Calabi: *On Kähler manifolds with vanishing canonical class*, Algebraic Geometry and Topology, Princeton University Press, 1955, pp. 78-89
- [CK] D. A. Cox and S. Katz: *Mirror Symmetry and Algebraic Geometry*, Mathematical Surveys and Monographs **68**, American Mathematical Society, Providence, 1999
- [Com1] A. Comessatti: *Fondamenti per la geometria sopra superficie razionali dal punto di vista reale*. Math. Ann. **73** (1913), pp. 1-72
- [Com2] A. Comessatti: *Sulla connessione delle superficie razionali reali*. Annali di Math. **23** (1914), pp. 215-283
- [Cox1] D. Cox: *The Homogeneous Coordinate Ring of a Toric Variety*. J. Algebraic Geometry **4** (1995), pp. 17-50
- [Cox2] D. Cox: *Recent Developments in Toric Geometry*. Algebraic Geometry-Santa Cruz (J. Kollár, R. Lazarsfeld and D. Morrison eds.), 1995
- [Dan] V. Danilov: *The geometry of toric varieties*. Russian Math. Surveys **33** (1978), pp. 97-154
- [DFN] B.A. Dubrovin, A.T. Fomenko, S.P. Novikov: *Modern Geometry - Methods and Applications. Part III. Introduction to Homology Theory*. Springer-Verlag, 1990
- [Dly1] Claire Delaunay: *Real Structures on Compact Toric Varieties*. Ph.D. thesis, Université de Strasbourg, 2004
- [Dly2] Claire Delaunay: *Real Structures on Smooth Compact Toric Surfaces*. Contemp. Math. **334**, American Mathematical Society, Providence, RI, 2003, pp. 267-290
- [DSV] J.-G. Dumas, B.D. Saunders and G. Villard: *On Efficient sparse Integer Matrix Smith Normal Form Computations*. J. Symbolic Computation **32** (2001), pp. 71-99

- [Frz1] M. Franz: *The integral cohomology of smooth toric varieties*. Proc. Steklovo Inst. Math **252** (2006), pp. 53-62
- [Frz2] M. Franz: *Convex - A Maple package for convex geometry*. Version 1.1 (2009). Available at <http://www.math.uwo.ca/~mfranz/convex>
- [Ful] W. Fulton: *Introduction to Toric Varieties*. Princeton U. Press, Princeton, NJ, 1993
- [Gbr] Mark Giesbrecht: *Probabilistic Computation of the Smith Normal Form of a Sparse Integer Matrix*. Algorithmic number theory (Henri Cohen ed.). Lecture Notes Comp. Sci. **1122** (1996), pp. 173-186
- [GKZ] I. Gelfand, M. Kapranov and A. Zelevinsky: *Discriminant, Resultants and Multidimensional Determinants*. Springer-Verlag, 1994
- [Gud] D.A. Gudkov: *The topology of curves of degree 6 and surfaces of degree 4*. Uchen. Zap. Gorkov. Univ. **87**, 1969. – English translation in Transl. AMS 112
- [Hse] Ch. Haase: *Lattice Polytopes and Triangulations With Applications to Toric Geometry*. Ph.D. thesis, Technische Universität Berlin, 2000
- [Har] A. Harnack: *Über die Vieltheiligkeit der ebenen algebraischen Curven*. Math. Ann. **10** (1876), pp. 189-199
- [Hart] Robin Hartshorne: *Algebraic Geometry*. Springer-Verlag, 1977
- [HGT] R. Daverman, R. Sher (eds.): *Handbook of Geometric Topology*. Elsevier, Amsterdam, 2002.
- [Hil] D. Hilbert: *Mathematische Probleme*. Göttinger Nachrichten (1900), pp. 253-297

- [Hob] John D. Hobby: *A natural lattice basis problem with applications*. Mathematics of Computation **67** (1998), No. 223, pp. 1149-1161
- [How1] Valerie Hower: *Hodge Spaces of Real Toric Varieties*. Collect. Math. **59** (2008), pp. 215-237
- [How2] Valerie Hower: *A Counterexample to the Maximality of Toric Varieties*. eprint arXiv:math/0611925v1
- [Hud] J. F. P. Hudson: *Piecewise Linear Topology*. W.A.Benjamin, Inc., New York-Amsterdam, 1969
- [IMS] I. Itenberg, G. Mikhalkin, E. Shustin: *Tropical Algebraic Geometry*. Birkhäuser, Basel-Boston-Berlin, 2007
- [ItVi] I. Itenberg, O. Viro: *Patchworking algebraic curves disproves the Ragsdale conjecture*. The Mathematical Intelligencer **18:1** (1996), pp. 19-28
- [Jor] A. Jordan: *Homology and Cohomology of Toric Varieties*. Ph. D. thesis, Konstanzer Schriften in Mathematik und Informatik **57** (1998), <http://www.inf.uni-konstanz.de/Schriften/preprints-1998.html#057>
- [Kha] Viatcheslav Kharlamov: The topological type of non-singular surfaces in $\mathbb{R}P^3$ of degree four, Funct. Anal. Appl. **10** (1976), pp. 299-305
- [Kol0] János Kollár: *Real Algebraic Surfaces*. eprint arXiv:alg-geom/9712003v1
- [Kol1] János Kollár: *Real Algebraic Threefolds I. Terminal Singularities*. Collect. Math. **49** (1998), No. 2-3, pp. 335-360
- [Kol2] János Kollár: *Real Algebraic Threefolds II. Minimal Model Program*. J. Amer. Math. Soc. **12** (1999), pp. 33-83

- [Kol3] János Kollár: *Real Algebraic Threefolds III. Conic Bundles*. J. Math. Sci. (New York) **94** (1999), pp. 996-1020
- [Kol4] János Kollár: *Real Algebraic Threefolds IV. Del Pezzo Fibrations*. Complex analysis and algebraic geometry, pp. 317-346, de Gruyter, Berlin, 2000
- [Kol5] János Kollár: *The Topology of Real Algebraic Varieties*. Current developments in mathematics 2000, pp. 197-231, Int. Press, Somerville, MA, 2001
- [Kon2] M. Kontsevich, Lecture at Orsay (December 7, 1995)
- [Kon1] M. Kontsevich: *Homological Algebra of Mirror Symmetry*. Proc. International Congress of Mathematicians (Zürich 1994), Birkhäuser, Basel, 1995, pp. 120-139
- [KS] Robin C. Kirby, Laurence C. Siebenmann *Foundational Essays on topological manifolds, smoothings and triangulations*. Annals of Mathematic Studies, Princeton University Press, New Jersey, 1977
- [Moi] E. Moise: *Affine structures in 3-manifolds*, V, Annals of Mathematics **56** (1952), pp. 458-480
- [MCP] C. McCrory and A. Parusinski: *Virtual Betti Numbers of Real Algebraic Varieties*. Comptes Rendus Acad. Sci. Paris, Ser. I **336** (2003), pp. 763-768
- [Mil] John Milnor: *Two complexes which are homeomorphic but combinatorially distinct*. Annals of Mathematics **74** (1961), No. 3, pp. 475-490
- [Nash] J. Nash: *Real algebraic manifolds*. Ann. Math. **56** (1952), pp. 405-421
- [Nik] V. Nikulin: *Integer symmetric bilinear forms and some of their geometric applications*. Math. USSR-Izv. **14** (1979), No. 1, pp. 103-167

- [Oda] T. Oda: *Convex Bodies and Algebraic Geometry: An Introduction to Toric Varieties*. Springer-Verlag, New York-Berlin-Heidelberg, 1988
- [Pap] Ch. Papakyriakopoulos: *A new proof of the invariance of the homology groups of a complex*, (Greek), Bull. Soc. Math. Grèce, (22) (1943), pp. 1-154
- [Pen] H. Pennaneac'h: *Virtual and Non-Virtual Betti Numbers*. Adv. Geom. **5** (2005), No. 2, pp. 187-193
- [Pls] Séminaire Palaiseau : Astérisque. Bd. 126: *Géométrie des Surfaces K3: Modules et Périodes*. Paris : Soc. Math. de France, 1985
- [RS] C. P. Rourke, B. J. Sanderson: *Introduction to Piecewise Topology*. Springer-Verlag New York-Berlin-Heidelberg, 1972
- [Rud] Yuli B. Rudyak: *Piecewise linear structures on topological manifolds*. "Mir", Moscow (1984), pp. 243-246 (Russian). eprint arXiv:math/0105047v1
- [FS] F. Schwertek: *Topologische Modelle von reellen K3-Flächen und die Viro-Methode*. Graduate thesis, Eberhard-Karls-Universität Tübingen, 2005
- [Sil] R. Silhol: *Real Algebraic Surfaces*. Lecture Notes in Math. 1392, Springer-Verlag, 1989
- [Sma] S. Smale: *Differentiable and combinatorial structures on manifolds*, Annals of Mathematics **74** (1961), No. 3, pp. 498-502
- [SYZ] A. Strominger, S.-T. Yau, E. Zaslow: *Mirror symmetry is T-duality*. Nucl. Phys. B **479** (1996), pp. 243-259
- [Uma] V. Uma: *On the Fundamental Group of Real Toric Varieties*. Proc. Indian Acad. Sci. (Math. Sci), **114** (February 2004), No. 1, pp. 15-31

- [Vi1] O. Viro: Patchworking Real Algebraic Varieties. Preprint 1995.
- [Vi2] O. Viro: *Gluing of plane real algebraic curves and construction of curves of degree 6 and 7*. Lect. Notes Math. (1060), 1984, Springer, Berlin, pp. 187-200
- [VHH] *ViroHS_Hom*: A Maple program for the computation of the homology groups of combinatorial patchwork hypersurfaces in real projective toric varieties. Available at <http://www.arlofin.de/Mathematik/Diss.html>
- [Yau] Shing-Tung Yau: *On the Ricci curvature of a compact Kähler manifold and the complex Monge-Ampère equation*, Comm. Pure Appl. Math. **31** (1978), pp. 339-411

Glossary of Notations

\overleftrightarrow{AB}	the join of A and B
P, Q	polyhedra
F	face of a polyhedron
α	linear form
$\text{Aff}(P)$	affine space generated by P
$\text{Lin}(P)$	linear space parallel to $\text{Aff}(P)$
σ	simplex / cone
K	polyhedral complex
$ K $	realization of K
$\mathcal{K}(P)$	face complex of K
∂P	boundary of P
$\text{Int}(P)$	interior of P
\hat{P}	barycenter of P
\tilde{K}	barycentric subdivision of K
\overline{P}	closure of P
\overline{K}	compactification of K
χ	Euler characteristic
Δ, Θ	lattice polytopes
$\Delta(i)$	i -dimensional faces of Δ
$l(\Delta)$	lattice points in Δ
$l^*(\Delta)$	lattice points in $\text{Int}(\Delta)$
$l^\partial(\Delta)$	lattice points in $\partial\Delta$
$\kappa(\Delta)$	number of edges in a unimodular triangulation of Δ

$\mu(\Delta)$	number of 2-dim. simplizes in a unimodular triangulation of Δ
Δ^*	dual polytope
Γ	face of Δ
Γ^*	dual face of Γ
v	vertex / lattice point
\bar{v}	image of v in $\mathbb{Z}/2\mathbb{Z}$
$\text{vol}_N(\Delta)$	normalized volume of Δ
\mathcal{T}	lattice triangulation / simplicial lattice complex
$\mathcal{T}(i)$	i -dimensional simplizes of \mathcal{T}
f_i	$\#\mathcal{T}(i)$
f_i^*	$\#\{\sigma \in \mathcal{T}(i) \mid \sigma \not\subset \partial \mathcal{T} \}$
f_i^∂	$\#\{\sigma \in \mathcal{T}(i) \mid \sigma \in \partial \mathcal{T} \}$
$f_{i,j}$	$\#\{\sigma \in \mathcal{T}(i) \mid \text{the minimal face of } \mathcal{T} \text{ containing } \sigma \text{ is } j\text{-dimensional}\}$
$P(\Delta; t), Q(\Delta; t)$	polynomials defined by the Ehrhart series
$\text{Lin}_2(\sigma)$	\mathbb{F}_2 -vector space spanned by the vertices of σ
$\dim_2 \sigma$	$\dim_{\mathbb{F}_2} \text{Lin}_2(\sigma)$
$\dim_2 \mathcal{T}$	$\dim_{\mathbb{F}_2} \sum_{\sigma \in \mathcal{T}} \text{Lin}_2(\sigma)$
$\text{Latt}(\Delta)$	$\text{Lin}(\Delta) \cap \mathbb{Z}^d$
\mathbb{S}_Δ	$\text{Hom}(\text{Latt}(\Delta), \{\pm 1\})$
ξ	element of \mathbb{S}_Δ
ξ^u	$\xi(u)$
$N_{\Delta/\Delta'}$	$\{\xi \in \mathbb{S}_\Delta \mid \xi \equiv 1 \text{ on } \text{Latt}(\Delta')\}$
$\hat{w}(u)$	$(-1)^{\langle u, w \rangle}$
\mathbb{K}	field
N	lattice
M	dual lattice
$N_{\mathbb{R}}, M_{\mathbb{R}}$	corresponding \mathbb{R} -vector spaces $N \otimes_{\mathbb{Z}} \mathbb{R}, M \otimes_{\mathbb{Z}} \mathbb{R}$
Σ	fan
$\text{supp}(\Sigma)$	support of Σ
σ^\vee	dual cone
\mathbb{A}	affine space
\mathbb{P}	projective space
X_σ	affine toric variety associated with the cone σ

X_Σ	toric variety associated with the fan Σ
X_Δ	toric variety associated with the rational polyhedron Δ
\mathbb{T}	the algebraic torus $(\mathbb{K}^*)^d$
O_σ	torus orbit corresponding to the cone σ
X_Σ^+	nonnegative part of the real toric variety X_Σ
\mathcal{L}	line bundle
D	divisor
ψ_D	support function of D
$\text{Pic}(X)$	Picard group of X
$A_{d-1}(X)$	Chow group of X
ρ	ray
$\mu, \mu^{(\xi)}$	moment maps
$\pi_1(X)$	fundamental group of X
H_c^i	i -th cohomology group with compact support
H_i	i -th homology group
b^i	i -th Betti number
β^i	i -th virtual Betti number
$\beta(X; t)$	virtual Poincare polynomial
$\text{cone}(\Theta)$	cone generated by $\Theta \times \{1\}$
$\gamma(\mathcal{T})$	$\sum_{\sigma \in \mathcal{T}} (-2)^{m - \dim \sigma}$
$\mathbf{1}$	constant function 1
T_g	orientable surface of genus g
$\Delta(f)$	Newton polytope of the Laurent polynomial f
f^Γ	Γ -truncation of the coefficients of f
Z_f	hypersurface defined by $f = 0$
ε	sign function
$\Delta^{(\xi)}$	copy of Δ
$\mathcal{T}^{(\xi)}$	copy of the triangulation of Δ
$\varepsilon^{(\xi)}(v)$	$\xi^v \varepsilon(v)$
\mathcal{T}_{X_Δ}	induced triangulation on X_Δ
$o(Z)$	orientation on Z
$X_{\Sigma(\Theta)}$	real toric variety associated with the fan consisting of $\text{cone}(\Theta)$
$X_{\Sigma(\Theta, \mathcal{T})}$	real local toric variety associated with the triangulation \mathcal{T} of Θ

$\varphi_{\Theta, \mathcal{T}}$	toric morphism $X_{\Sigma(\Theta, \mathcal{T})} \rightarrow X_{\Sigma(\Theta)}$
x_{Θ}	unique torus-invariant point in $X_{\Sigma(\Theta)}$
Γ_{σ}	minimal face of a polyhedron containing σ
E_{σ}	set of sign functions on the vertices of σ
G_{σ}	$\mathbb{S}_{\Gamma_{\sigma}}$
St_{σ}	stabilizer of the action of G_{σ} on E_{σ}

Appendix A - Zusammenfassung auf Deutsch

Der Leitgedanke der vorliegenden Arbeit besteht darin, die Topologie von reellen Calabi-Yau-Varietäten, insbesondere der 3-dimensionalen, zu untersuchen.

Eine (komplexe) Calabi-Yau-Varietät wird dabei eine glatte projektive komplexe algebraische Varietät X genannt, falls $H^i(X, \mathcal{O}_X) = 0$ für alle $i = 1, \dots, \dim X - 1$ gilt und die kanonische Klasse K_X trivial ist (die letzte Eigenschaft ist äquivalent zu der Existenz einer global definierten rationalen $(\dim X)$ -Form, die weder Null- noch Polstellen besitzt). 1-dimensionale Calabi-Yau-Varietäten nennt man elliptische Kurven, 2-dimensionale K3-Flächen. Von einer reellen Calabi-Yau-Varietät spricht man, wenn ihre Komplexifizierung eine komplexe Calabi-Yau-Varietät ist. Die Eigenschaft $K_X = 0$ hat die topologische Konsequenz, dass die Varietäten als reelle Mannigfaltigkeiten orientierbar sind.

3-dimensionale (komplexe) Calabi-Yau-Varietäten spielen eine wichtige Rolle in der String-Theorie. Physikalische Erwägungen geben zu der Vermutung Anlass, dass die Calabi-Yau-Varietäten in Paaren (V, V') auftreten, so dass die Eigenschaften von V und V' eng miteinander verknüpft sind. Diese Relation, die Mirror-Symmetrie

genannt wird, konnte bis heute nicht vollständig mathematisch erklärt werden. Aufgrund der weitreichenden Konsequenzen in der algebraischen Geometrie, die z.T. überprüft werden konnten, steht sie im Mittelpunkt eines regen Forschungsinteresses neuerer Zeit.

Batyrev zeigte in [Bat], wie Calabi-Yau-Varietäten aus Hyperflächen von torischen Gorenstein-Fano-Varietäten erhalten werden können. Im Mittelpunkt der Konstruktion steht dabei ein reflexives Polytop Δ , das sowohl die torische Varietät definiert als auch als Newton-Polytop für die Hyperfläche fungiert. Die Auflösung eventueller Singularitäten kann durch eine unimodulare Triangulierung von Δ^* , dem dualen Polytop, bestimmt werden. Eine analoge Konstruktion mit Δ^* anstelle von Δ liefert einen guten Kandidaten für den Mirror-Partner. Diese Klasse von Calabi-Yau-Varietäten schließt alle früher bekannten Beispiele ein. Da sie über \mathbb{R} definiert ist, bildet sie den Ausgangspunkt unserer Betrachtungen.

Zunächst untersuchen wir den Desingularisierungsprozess, der sich lokal durch eine torische Varietät, die zu einem Fächer über einem Gitterpolytop mit unimodularer Triangulierung assoziiert ist, beschreiben lässt. Der Versuch der topologischen Klassifikation solcher „reeller lokaler torischer Calabi-Yau-Varietäten“, insbesondere in den Dimensionen 2 und 3, weist Parallelen zu einer Arbeit von Delaunay ([Dly1] und [Dly2]) auf, doch während dort glatte kompakte torische Varietäten untersucht werden, derer es nur wenige gibt und die daher einzeln abgearbeitet werden können, ist die Aufgabe in unserem Fall durch die unendliche Vielfalt an Polytopen und Triangulierungen deutlich komplexer.

Wir zeigen, dass (in allen Dimensionen) die Eulerzahl und die virtuellen Betti-Zahlen unabhängig von der gewählten Triangulierung sind. In den Dimensionen 2 und 3 gilt dies auch für die klassischen Betti-Zahlen. Wir führen eine Kompaktifizierung mit Rand ein, deren Rand nur vom Rand des Polytops (und dessen induzierter Triangulierung) abhängt. Die Anzahl der Zusammenhangskomponenten des Varietätenrandes ergibt sich als Index einer durch die Punkte des Polytoprandes definierten Untergruppe in $(\mathbb{Z}/2\mathbb{Z})^{d-1}$.

Die 2-dimensionalen reellen lokalen torischen Calabi-Yau-Varie-

täten X werden durch ein Intervall $[0, n]$ und die eindeutige Unterteilung in Teilintervalle der Länge 1 gegeben. Der Parameter n bestimmt ihre Topologie: Für gerades n ist $X \cong T_{\frac{n}{2}-1} \setminus \{2 \text{ pkt.}\}$ für ungerades n ist $X \cong T_{\frac{n-1}{2}} \setminus \{\text{pkt.}\}$, wobei T_g die orientierbare Fläche vom Geschlecht g bezeichne.

Für die 3-dimensionalen Varietäten, gegeben zu einem Gitterpolytop Θ , gilt $H_c^0(X, \mathbb{Z}) = 0$, $H_c^1(X, \mathbb{Z}) \cong \mathbb{Z}^{l(\text{Int}\Theta)-s}$, $H_c^2(X, \mathbb{Z}) \cong \mathbb{Z}^r \times (\mathbb{Z}/2\mathbb{Z})^s$ und $H_c^3(X, \mathbb{Z}) = \mathbb{Z}$, wobei l die Anzahl der Gitterpunkte bezeichne und $r + s = l(\partial\Theta) - 3$. r und s hängen von der Triangulierung ab. Wir vermuten, dass die Topologie schon durch die Fundamentalgruppe eindeutig bestimmt ist.

Die Formeln für die Euler-Zahlen lassen sich verwenden, um kombinatorische Relationen für Gitterpolytope von gerader Dimension, die eine unimodulare Triangulierung besitzen, aufzustellen. Für 4-dimensionale Polytope Θ erhalten wir

$$\text{vol}(\Theta) = 2\mu(\Theta) - 5\kappa(\Theta) + 9l(\Theta) - 14.$$

Dabei bezeichne μ, κ die (eindeutig bestimmte) Anzahl der 2- bzw. 1-dimensionalen Simplexes in einer unimodularen Triangulierung.

Den kombinatorischen Charakter der lokalen Calabi-Yau-Varietäten setzen wir auch auf die kompakten Varietäten fort, indem wir die Hyperflächen in Batyrev's Konstruktion mit Hilfe einer Methode von Viro erstellen. Dabei wird für das Polytop Δ ebenfalls eine Triangulierung gewählt, sowie eine Vorzeichenfunktion auf deren Ecken. Es erweist sich als vorteilhaft auch hier die Triangulierung unimodular zu wählen. In diesem Fall erhalten wir, dass für die kompakten Calabi-Yau-Varietäten die Eulerzahl unabhängig von allen Wahlen in der Konstruktion ist. Für eine fixierte Viro-Hyperfläche sind ferner die Betti-Zahlen von der Wahl der Auflösung unabhängig. Letzteres spiegelt ein weiteres Ergebnis von Batyrev ([Bat2]) wider, der zeigte, dass birational äquivalente komplexe Calabi-Yau-Varietäten gleiche Betti-Zahlen besitzen. Dagegen geben wir Beispiele dafür an, dass die Kohomologiegruppen mit \mathbb{Z} -Koeffizienten in der Tat von der Wahl der Auflösung abhängt.

Für reelle K3-Flächen ergibt sich in unserer Konstruktion immer die Eulerzahl -16 . Aufgrund der bekannten Klassifikation läßt sich ableiten, dass diese maximal 2 Zusammenhangskomponenten haben können. Für beide möglichen Fälle geben wir Beispiele an.

Mit Hilfe der Formel für die Eulerzahl lassen sich ebenfalls wieder kombinatorische Relationen für Polytope finden. Für 4-dimensionale reflexive Polytope Δ , die eine unimodulare kohärente Triangulierung zulassen, erhalten wir

$$\begin{aligned} & -15f_{4,4} + 14f_{3,4} + 7f_{3,3} - 12f_{2,4} - f_{2,3} - 3f_{2,2} \\ & + f_{1,4} + 4f_{1,3} + 2f_{1,2} + f_{1,1} \\ & = \sum_{F \in \Delta(2)} l(\partial F)(2 - l(F^*)) - \sum_{\Theta \in \Delta(1)} \text{vol}(\Theta)(3 - l(\partial\Theta^*)), \end{aligned}$$

wobei $f_{i,j}$ die Anzahl der i -dimensionalen Simplizes, die im Inneren einer j -dimensionalen Seite liegen, bezeichne.

Die natürliche Zellzerlegung der Viro-Hyperflächen lässt sich nutzen, um deren Homologiegruppen mit beliebigen Koeffizienten zu berechnen. Dazu implementierten wir ein Programm in Maple, das diese Aufgabe löst. Für glatte Hyperflächen erhält man so direkt vollständige Informationen über die Homologie von Calabi-Yau-Varietäten. Leider erfordern gerade die glatten Fälle einen hohen Aufwand an Rechenzeit und Speicherkapazität, so dass in Dimension 3 nur die Anzahl der Zusammenhangskomponenten bestimmt werden konnte. Die durchgeführten Experimente an glatten und nicht glatten Hyperflächen legen die Vermutung nahe, dass (bei unimodularer Triangulierung) in jeder Dimension maximal 2 Zusammenhangskomponenten auftreten können. In Dimension 3 trat zudem nur 2-Torsion auf. Dies spiegelt ebenfalls eine ähnliche Situation für komplexe Calabi-Yau-Hyperflächen wider: In [BatKr] zeigen Batyrev und Kreuzer, dass p -Torsion einerseits zwar sehr selten auftritt, nämlich in 32 von 473 800 776 Fällen, andererseits aber die Fälle mit 2-Torsion dominieren: In 29 Fällen ist $p = 2$, in 2 Fällen $p = 3$ und in einem Fall $p = 5$.